

CRANE

FLUID SYSTEMS

ISSUE 5

GENERAL VALVES

SOLUTIONS FOR THE EVERYDAY



OUR GENIUS IS VALVES

CRANE

BUILDING SERVICES & UTILITIES



UNITED KINGDOM

Ipswich (Headquarters)

Crane BS&U
 Crane House
 West Road
 Ipswich
 IP3 9FJ
 UK
Tel: +44 1473 277 300

Hitchin (Manufacturing)

Crane BS&U
 46-48 Wilbury Way
 Hitchin
 Hertfordshire
 SG4 0UD
 UK
Tel: +44 1462 443 322

Northampton (Distribution Centre)

Crane BS&U
 Lower Farm Road
 Moulton Park Industrial
 Estate - Northampton
 NN3 6XF
 UK
Tel: +44 1604 817 860



Headquarters



Manufacturing



Distribution Centre



Sales Office



INTERNATIONAL

Dubai
(Distribution Centre)

Crane BS&U
Jebel Ali Free Zone
South Zone 2
PO BOX 17415
Dubai
UAE
Tel: +971 880 9989

Dubai
(Corporate Office)

Crane BS&U
Building 4, Office 901
The Galleries
PO BOX 17415
Downtown Jebel Ali
Dubai
UAE
Tel: +971 4816 5800

Suzhou
(Manufacturing)

Crane Fluid & Gas
(Suzhou) Ltd.
1 Runsheng Road
Shengpu Sip
Jiangsu Province
215126 Suzhou
China
Tel: +86 5126 28615 0088

Ningjin
(Manufacturing)

8 Youji Street
Ningjin
00863195856825
China
Hebei
Tel: +86 319 5802730

Crane Building Services & Utilities forms part of the Fluid Handling Group within Crane Co., which was founded in 1855, and is now a multi-industry manufacturer that generated net sales of \$3.3bn in 2018.

In 1906, James E. Bennett set up a business in London as a coppersmith. He soon recognised a growing interest in the trade for the latest American pipe fittings and valves, and turned his attention to importing. Amongst the products he introduced to the British industry were those of Crane Co., a thriving American Company founded in the mid-19th century.

Crane soon realised that a manufacturing unit in the UK would help expand their international business. In 1919, Crane Co. purchased the assets of the English Company and changed its name to Crane-Bennett Limited with the intention of manufacturing valves and fittings in the UK.

Today, the Company forms part of Crane Building Services & Utilities, which was created as a result of Crane Ltd acquiring Viking Johnson, Helden and WASK in 2003 and Hattersley in 2004. The most recent acquisition was Delta Fluid Products in 2008. Each of these companies has a long and distinguished history:

- Crane Limited founded in Ipswich in 1919
- Viking Johnson founded in Hitchin in the 1930s
- WASK founded in Keighley in 1888
- Delta Fluid Products founded in 1900

The name Crane speaks of who we are, what we stand for and how our customers perceive us: a company with history and tradition, but also a company that is innovative, quality-minded and one which acts with integrity, still holding to the resolution of its founder.

Crane Co. was founded on the 5th July 1855 by Richard Teller Crane who made the following resolution:

"I am resolved to conduct my business in the strictest honesty and fairness; to avoid all deception and trickery; to deal fairly with both customers and competitors; to be liberal and just towards employees; and to put my whole mind upon the business."

The essence of this resolution is the business policy of Crane Co. today.



Richard Teller Crane



In 1906 James E. Bennett set up a business in London as a Coppersmith. He soon recognised a growing interest in the trade for the latest American pipe fittings and valves, and turned his attention to importing. Amongst the products he introduced to the British industry were those of Crane Co., a thriving American Company founded in the mid-19th century.

Now, for more than 100 years, Crane Fluid Systems has manufactured a range of valves and pipe fittings for the Building Services industry, and is developing a range of next generation balancing solutions. The product portfolio comprises a full range of traditional valves: ball, butterfly, check, gate, globe and radiator valves as well as strainers and drain cocks.

In addition, there is a range of WRAS approved Public Health Valves for hot and cold water systems that includes thermal circulation valves that assist in preventing Legionnaires' Disease, as well as a range of pressure reducing valves.

Also available are malleable iron Pipe Fittings and unions, many of which carry the BSI Kitemark.

The Crane Fluid Systems ProBalance range offers a wide variety of Flow Management Systems and Static Balancing Valves, providing the ultimate in accuracy and reliability.



Ipswich 1921. Mr J. E. Bennett and party drinking a toast after the foundation stone was laid



Ipswich Works



PROJECT

Disneyland

Opened in 2005, Hong Kong Disneyland is located on reclaimed land in Penny's Bay, Lantau Island. The park has a daily capacity of 34,000 visitors the least of all Disneyland parks and attracts around 7 - 8 million visitors annually.

Hong Kong Disneyland currently occupies 49.9 hectares (123 acres) and plans to increase capacity to handle up to 10 million visitors annually over a 15-year expansion period.

Hong Kong Disneyland had one of the shortest construction period among all the Disneyland theme parks, of just over two years. Crane FS supplied a selection of General Valves to the build.

LOCATION:

Hong Kong

CONTRACTOR:

Tozen HK Ltd











CLIENT:

Walt Disney Company

SPECIFICATION:

General valves



INTRODUCTION		GENERAL VALVES		GENERAL INFORMATION	
Crane BS&U International Locations	2			HVAC Quick Selection Guide	6
Our Heritage	4			Flange Tables	144
About us	5			Typical Kv Values	154
				Quality Assurance	155
				Case Study Index	157
				Figure Number Index	158
				Building Services Brands	159

Valid as of 02/03/20

For full product specifications please refer to the CFS website: www.cranefs.com

VALVE FUNCTION	VALVE TYPE		BODY MATERIAL	CHILLED WATER, LTHW AND MTHW								CWS		DHWS		AIR/GAS		OIL		
				PN6		PN10		PN16		PN25		≤50mm	≥65mm	≤50mm	≥65mm	≤50mm	≥65mm	≤50mm	≥65mm	
				≤50mm	≥65mm	≤50mm	≥65mm	≤50mm	≥65mm	≤50mm	≥65mm									
ISOLATION	GATE	THREADED	BRONZE	D151	D151	D151	D151	D151	D151	D151X	D151X	D151	D151	D151	D151	-	-	D151	D151	
		THREADED	DZR	D151A	D151A	D151A	D151A	D151A	D151A	-	-	D151A	D151A	D151A	D151A	-	-	D151A	D151A	
		FLANGED	BRONZE	-	-	-	DM160	-	DM160	DM161	DM161	-	-	-	-	-	-	-	-	-
		COMPRESSION	BRONZE	D155C	-	D155C	-	D155C	-	-	-	D155C	-	D155C	-	-	-	-	-	-
		FLANGED	CAST IRON	-	FM52	-	FM57	-	FM63	-	-	-	-	-	-	-	-	-	-	FM52
	BALL	THREADED	BRONZE	D171	-	D171	-	D171	-	D171	D171	D171	-	D171	-	D171	-	D171	-	
		THREADED	DZR	D171A	-	D171A	-	D171A	-	D171A	-	D171A	-	D171A	-	D171A	-	-	-	
		THREADED	BRASS	-	-	-	-	-	-	-	-	-	-	-	-	D191	-	D191	-	
		COMPRESSION	BRONZE	D171C	-	D171C	-	D171C	-	-	-	D171C	-	D171C	-	D171C	-	D171C	-	
		COMPRESSION	DZR	-	-	-	-	-	-	-	-	D181C	-	D181C	-	-	-	-	-	
	BUTTERFLY	SEMI-LUGGED	DUCTILE IRON	-	-	F611 F612 F621 F622 F626 F627 (See Note 1)	F611 F612 F621 F622 F626 F627 (See Note 1)	-	-	F621 WRAS	F621 WRAS	F621 WRAS	F621 WRAS	F611	F611 F622	REFER TO CRANE				
		FULLY LUGGED		-	-	F614 F615 F624 F625 F628 F629 (See Note 2)	F614 F615 F624 F625 F628 F629 (See Note 2)	DM 975G	DM 975G	F624 WRAS	F624 WRAS	F624 WRAS	F624 WRAS	F614	F614 F615					
	NON-RETURN	SWING CHECK	RESILIENT SEAT	BRONZE	D140	D140	D140	D140	D140	D140	D140	D140	-	-	-	-	D140	-	-	
			METAL SEAT		D138	D138	D138	D138	D138	D138	D138	D138	D138	-	D138	-	D138	-	-	
			RESILIENT SEAT	CAST IRON	-	-	-	-	-	FM469	-	-	-	-	-	-	FM469	-	-	
METAL SEAT			-		-	-	-	-	FM492	-	-	-	-	-	-	-	-	-		
WAFER CHECK		RESILIENT SEAT	CAST IRON	-	-	-	-	-	FM451	FM455	FM455	-	-	-	-	-	-	-		
		METAL SEAT		-	D130W	-	-	-	FM450	-	-	-	-	-	-	-	-	-		
PIPELINE PROTECTION	STRAINER Y-TYPE	THREADED	BRONZE	D297	-	D297	-	D297	-	-	D297	-	D297	-	D297	-	D297			
		FLANGED	CAST IRON	-	-	-	FM276	-	FM276	FM278	FM278	-	-	-	-	FM276	-	FM276		
		THREADED	MALLEABLE IRON	F273	-	F273	-	F273	-	F273	-	-	-	-	-	-	-			
DRAINING	DRAW OFF BALL	BRONZE	D171 MHU	-	D171 MHU	-	D171 MHU	-	-	-	D171 MHU	-	D171 MHU	-	-	-	-			
	DRAINING TAP	BRONZE	D340	-	D340	-	D340	-	-	-	D340	-	D340	-	-	-	-			
	DRAW OFF COCK	BRONZE	D344 ^{1/2}	-	D344 ^{1/2}	-	D344 ^{1/2}	-	-	-	D344 ^{1/2}	-	D344 ^{1/2}	-	-	-	-			

(Note 1) Valves are suitable for use with flanges conforming to BS EN 1092-2 PN10 or PN16 and ANSI B16.1 Class 125 (Sizes 2" - 12"). Sizes 350mm to 600mm suitable for use with PN16 flanges only.

(Note 2) Valves are suitable for use with flanges conforming to BS EN 1092-2 PN10 or PN16.

Valid as of 07/06/16

Every effort has been made to ensure that the information contained in this publication is accurate at the time of publishing. Crane Ltd assumes no responsibility or liability for typographical errors or omissions or for any misinterpretation of the information within the publication and reserves the right to change without notice.

For full product specifications please refer to the CFS website: www.cranefs.com

FUNCTION	VALVE TYPE		BODY MATERIAL	THREADED/ COMPRESSION			FLANGED/ LUGGED	
				PN10	PN16	PN25	PN16	PN25
REGULATION	DRV	DOUBLE REGULATING VALVE	BRONZE	-	-	D921 D923*	-	-
			DUCTILE IRON	-	-	-	DM921 DM925G	DM975G
FLOW MEASUREMENT	FMD	FLOW MEASUREMENT DEVICE	DZR	-	-	D901 D902*	-	-
			STAINLESS STEEL	-	-	-	DM900	DM900
CIRCUIT BALANCING	2 UNIT DRV + FMD	DOUBLE REGULATING VALVE + FLOW MEASUREMENT DEVICE	BRONZE/DZR	-	-	D921 + D901 D923* + D902*	-	-
			DUCTILE IRON	-	-	-	DM921 + DM900 DM925G + DM900	DM975G + DM900
	SINGLE UNIT FODRV	FIXED ORIFICE DOUBLE REGULATING VALVE	BRONZE	-	-	D931 D933* D934** D981P for use with actuator D983P* for use with actuator D984P** for use with actuator	-	-
			DUCTILE IRON	-	-	-	DM941 DM950G	-
	SINGLE UNIT VODRV	VARIABLE ORIFICE DOUBLE REGULATING VALVE	DUCTILE IRON	-	-	-	DM931	-
SINGLE UNIT FODRV	TERMINAL UNIT FLOW MANAGEMENT SYSTEM	BRONZE	-	Dominator® Z3000 Series	-	-	-	
MANIFOLD COMMISSIONING SYSTEM	MULTIPLE UNIT FODRV	TERMINAL UNIT FLOW MANAGEMENT SYSTEM	BRONZE	-	CommPac	-	-	-
PRESSURE INDEPENDENT CONTROL	PICV		BRASS/ CAST IRON	-	D991	-	DPIC992F	-
THERMAL BALANCING	TBV	<10m CIRCUITS	BRONZE	-	D1880	-	-	-
		>10m CIRCUITS			D1890			
	TEMPERATURE POCKET	MULTITEE			D1892			
THERMOSTATIC MIXING	TMV 3	WITHOUT ISOLATION	DZR	D1088	-	-	-	-
		WITH ISOLATION		D1089				

* Low Flow

** Ultra Low Flow

Valid as of 070616

Every effort has been made to ensure that the information contained in this publication is accurate at the time of publishing. Crane Ltd assumes no responsibility or liability for typographical errors or omissions or for any misinterpretation of the information within the publication and reserves the right to change without notice.

PROJECT

Arsenal Emirates Stadium

Crane Fluid Systems' Dominators – ProBalance balancing valves have been installed in the 60,335 capacity home of Arsenal Football Club, the Emirates Stadium. The heating and air-conditioning of the office building and player's changing rooms are controlled by fan coil units, in which the Dominator is installed.

Completed in August 2006, the football stadium has four tiers of seating covered by 30,000sqm of roofing, which makes it the second largest football stadium in England, behind Manchester United's Old Trafford. In 2004, Emirates Airline signed a fifteen year contract for the naming rights of the stadium, a deal worth approximately £100 million.

The Dominator, which is part of Crane FS ProBalance range, is a compact, prefabricated unit that combines a control valve, flow measurement device, bypass valve, strainer and drain, ready for simple and fast on-site connection to fan coils and other terminal units.

CONTRACTOR:

MJN Colston Limited (Croydon)

SPECIFICATION:

Dominators ProBalance balancing valves





S Shand-Brown

Air Vents/De-Aerators

Offering an efficient performance, the Crane Fluid System Air Vents remove inevitable and potentially dangerous air trapped in the system. Designed to simplify the venting process, for single or multi-boiler and calorifier installations, the range offers savings in time and costs.

Fig. No.	PN Rating	End Connections	Size Range	Cap Type	Shutoff Valve
D2003†	10	Threaded	3/8 - 1/2"	Standard	No
D2003†	10	Threaded	3/4 - 1"	Hygroscopic	No
D2004†	10	Threaded	1/2"	Standard	Yes

† WRAS approved product

D2003



D2003 & D2004

Automatic Air Vent



PN10

Features & Benefits

- Removes inevitable potentially dangerous air trapped in system
- Simplifies the venting process
- Saves time and costs
- WRAS Approved to 85°C
- A shut-off valve option is available in size 1/2 inch. Please specify when ordering D2004.

Materials

PART	MATERIAL	SPECIFICATION	
		BS EN	ASTM
Body	Brass	12165 CW617N	B455 C37710
Cover	Brass	12165 CW617N	B455 C37710
Float	Polypropylene	-	-
Seals	EPDM	-	-
Plastic Cap	Plastic	-	-
Hygroscopic Cap	Brass	12165 CW614N	B455 C38500
Shut-Off Valve	Brass	12165 CW614N	B455 C38500
Obturator Stem	Brass	12165 CW614N	B455 C38500



GENERAL VALVES

Dimensional Drawing

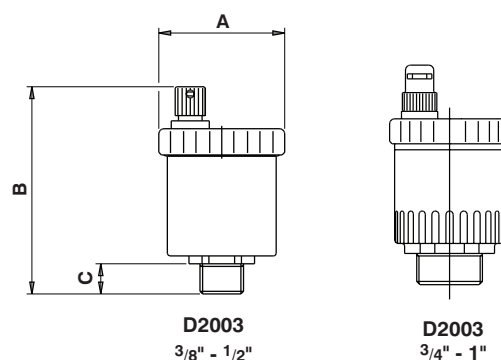

Dimensions & Weights

FIG NUMBER	SIZE (inch)	A (inch)	B (inch)	C (inch)	WEIGHT (kg)
D2003	3/8	48	79	11	0.18
	1/2	48	79	11	0.18
	3/4	48	86	11	0.18
	1	48	86	11	0.18
D2004	1/2	48	96	11	0.23

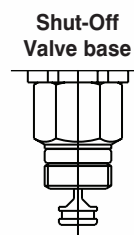
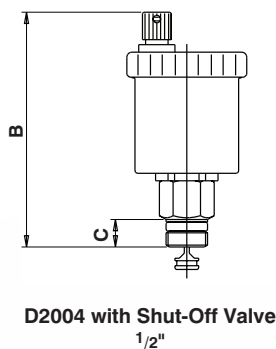

NOTE

D2004 version with Shut-Off Valve base allows the Automatic Air Vent to be removed without draining the system

Pressure/Temperature Ratings

TEMPERATURE (°C)	-10 to 120
PRESSURE (BAR)	16

Intermediate pressure ratings shall be determined by interpolation.

PRESSURE RATING: 10 bar

TEMPERATURE RATING:

D2003 – 120°C
D2004 – 110°C

MAXIMUM DISCHARGE PRESSURE: 2.5 bar

SPECIFICATION: Brass body and cover. Polypropylene float. EPDM seals. WRAS Approved Product to 85°C. BSP parallel thread.

D2004 Shut-Off Valve option available in size 1/2".

D2003 size 3/8" & 1/2" supplied with Plastic Cap.

D2003 size 3/4" & 1" supplied with Hygroscopic Cap.

Hygroscopic Cap:

This contains a fibre washer which, under normal working conditions remains dry and allows air to escape. In the event of water leakage, the fibre swells and minimises any water leakage from the air vent to prevent damage.

Valid as of 270220

Every effort has been made to ensure that the information contained in this publication is accurate at the time of publishing. Crane Ltd assumes no responsibility or liability for typographical errors or omissions or for any misinterpretation of the information within the publication and reserves the right to change without notice.

Ball Valves

The Crane Fluid System Series of ball valves consists of compact, lightweight units which are easy to install and operate, yet their ability to withstand robust construction ensures long, trouble-free service life. They offer full flow with minimum turbulence in the open position and bubble tight closure in the closed position. Only a quarter-turn is required to fully open or close the valve.

Fig. No.	PN Rating	End Connections	Size Range	Body Material	Operator	Special Application
D171	25	Threaded	1/2 - 2"	Bronze	Lever	None
D171EXT	25	Threaded	1/2 - 2"	Bronze	Lever + Extension	None
D171T	25	Threaded	1/2 - 2"	Bronze	T-Handle	None
D171LS	25	Threaded	1/2 - 2"	Bronze	Lockshield	None
D171C	16	Compression	15 - 54mm	Bronze	Lever	None
D171CEXT	16	Compression	15 - 54mm	Bronze	Lever + Extension	None
D171A†	25	Threaded	1/4 - 2"	DZR Brass	Lever	None
D171AEXT†	25	Threaded	1/4 - 2"	DZR Brass	Lever + Extension	None
D171ATH†	25	Threaded	1/2 - 2"	DZR Brass	T-Handle	None
D171ALS†	25	Threaded	1/2 - 2"	DZR Brass	Lockshield	None
D171AC†	16	Compression	15 - 54mm	DZR Brass	Lever	None
D171ACEXT†	16	Compression	15 - 54mm	DZR Brass	Lever + Extension	None
D171ACTH†	16	Compression	15 - 54mm	DZR Brass	T-Handle	None
D171ACLS†	16	Compression	15 - 54mm	DZR Brass	Lockshield	None
D171MHU	25	Threaded	G1/2 - G1"	Bronze	Lever	Male Hose Union
D171MHULS	25	Threaded	G1/2 - G1"	Bronze	Lockshield	Male Hose Union
D171CT†	16	Compression	15 - 28mm	Bronze	T-Handle	None
D171CLS†	16	Compression	15 - 28mm	Bronze	Lockshield	None
D191	25*	Threaded	1/4 - 2"	DZR Brass	Lever	Gas
D181C†	16	Compression	15 - 22mm	Chrome Plated DZR Brass	Lever***	None

† WRAS approved product

* 25 Bar for non-gas applications. 5 Bar for gas applications

** 16 Bar for non-gas applications. 5 Bar for gas applications

*** Lever can be removed to allow for screwdriver operation



Secondary O-Ring seal, for additional leakage protection, aids resistance to site installation damage

1

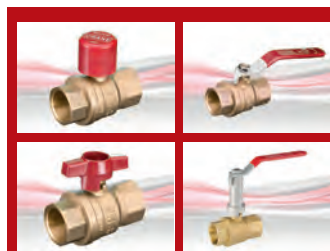

Multiple operating handle options (Clockwise from top right), quarter turn lever, extended stem lever, T-Handle & lockshield

Loctite 648 is used on the main joint threads to give more strength and resistance to installation damage

2

Available in different taper thread options - BS EN 10226-2 or ANSI B1.20.1

3

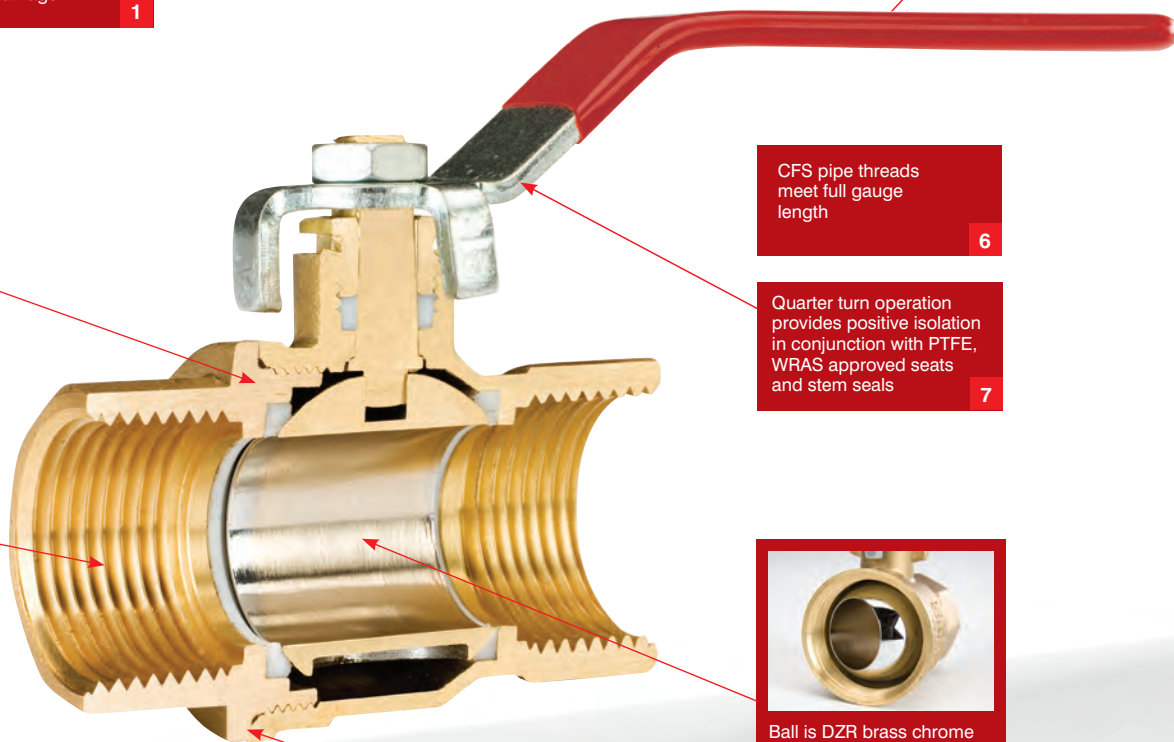

CFS pipe threads meet full gauge length

6

Quarter turn operation provides positive isolation in conjunction with PTFE, WRAS approved seats and stem seals

7



Ball is DZR brass chrome plated, designed for a long life. Temperature range is -10° to 120° C. Ball is full bore

Primary metal to metal seal

4

D171 / D171EXS

Bronze Ball Valve/Extended Stem Bronze Ball Valve



D171

PN25

Features & Benefits

- **D171** Ball Valves are light, compact units which are easy to install and operate, yet their robust construction ensures long, trouble free service life.
- **D171** and **D171EXS** are WRAS approved for use on hot and cold water systems up to 85°C.

Materials

PART	MATERIAL	SIZES
Body	Bronze BS EN 1982 CC491K	All
Seat Retainer	Bronze BS EN 1982 CC491K	All
Ball	DZR Brass BS EN 12165 CW602N (Chrome Plated)	All
Seat Ring	PTFE	All
Stem	DZR Brass BS EN 12164 CW602N	All
Packing	PTFE	All
Gland Nut	DZR Brass BS EN 12164 CW602N	1/4 - 2
Lever	Mild Steel (Zinc Plated)	All
Screw	Mild Steel (Zinc Plated)	All
Lever Cover	PVC	All
Extension Housing	Aluminium	D171EXS
Extension Stem	Brass BS EN 12164 CW602N	D171EXS



D171EXS



Dimensions & Weights

SIZE (inch)	WEIGHT (kg)	A (mm)	B (mm)	C (mm)	C1 (mm) D171EXS	D (mm)
1/4	0.15	46	10	39	-	81
3/8	0.15	46	10	39	-	81
1/2	0.22	57	15	52	97	92
3/4	0.45	67	20	58	98	92
1	0.69	77	25	66	118	127
1 1/4	1.12	91	32	72	124	127
1 1/2	1.67	103	40	82	142	142
2	2.93	122	50	90	149	142
2 1/2	4.98	153	65	117	-	202
3	8.75	179	80	132	-	282

Dimensional Drawing

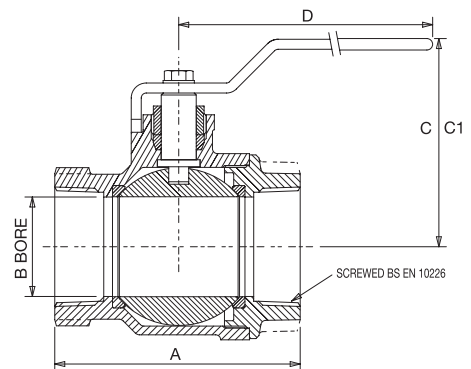

Pressure/Temperature Ratings

Threaded

TEMPERATURE (°C)	-10 to 100	110	120	186
PRESSURE (BAR)	25.0	23.4	21.8	10.5

Intermediate pressure ratings shall be determined by interpolation.

PRESSURE RATING: PN25

TEMPERATURE OPERATING RANGE: -10 To 186°C

UK END CONNECTION: Taper Threaded To BS EN 10226-2 (Iso 7-1) Formerly BS 21

US END CONNECTION: ANSI B1.20.1 (please add suffix AT to denote American Thread)

OPERATOR: Lever

SPECIFICATION: Quarter Turn, Tight Shut-Off. This Valve Is Not Suitable For Use On Group 1 Gases Or Unstable Fluids, as defined by the Pressure Equipment Directive 2014/68/EU.*

* See page 155 for more information

Valid as of 030220

Every effort has been made to ensure that the information contained in this publication is accurate at the time of publishing. Crane Ltd assumes no responsibility or liability for typographical errors or omissions or for any misinterpretation of the information within the publication and reserves the right to change without notice.

D171T

T-Handle Bronze Ball Valve



D171T

D171LS

Lockshield Bronze Ball Valve

PN25

Features & Benefits

Crane D171 Ball Valves are light, compact units which are easy to install and operate, yet their robust construction ensures long, trouble free service life. In addition the D171T and D171LS are WRAS approved for use on hot and cold water systems up to 85°C.

Materials

PART	MATERIAL	SIZES
Body	Bronze BS EN 1982 CC491K	All
Seat Retainer	Bronze BS EN 1982 CC491K	All
Ball	DZR Brass BS EN 12165 CW602N	All
Seats	PTFE	All
Stem	DZR Brass BS EN 12164 CW602N	All
Packing	PTFE	All
Gland Nut	DZR Brass BS EN 12164 CW602N	All
T-Handle	Aluminium	D171T
Screw	Steel (Zinc Plated)	D171T
Lockshield Cap	Brass BS EN 12164 CW617N	D171LS
Screw	Mild Steel	D171LS
Lockshield Cover	Nylon 6	D171LS

Dimensions & Weights

SIZE (inch)	WEIGHT (kg)	A (mm)	B (mm)	C (mm)	C1 (mm) D171LS	D (mm)	D1 (mm) D171LS
3/8	0.13	46	10	31	-	38	-
1/2	0.2	57	15	40	48	55	36
3/8	0.41	67	20	43	51	55	36
1	0.64	77	25	53	58	83	39
1 1/4	1.07	91	32	58	63	83	39
1 1/2	1.57	103	40	73	76	108	49
2	2.83	122	50	80	84	108	49



GENERAL VALVES

Dimensional Drawing

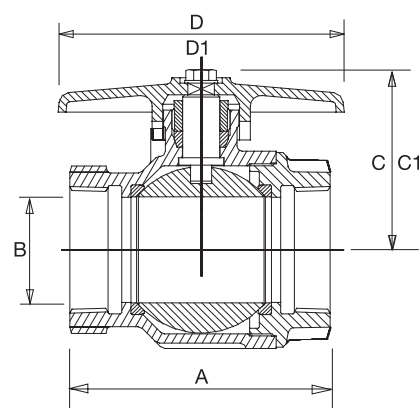

Pressure/Temperature Ratings

TEMPERATURE (°C)	-10 to 100	110	120	186
PRESSURE (BAR)	25.0	23.4	21.8	10.5

Intermediate pressure ratings shall be determined by interpolation.

PRESSURE RATING: PN25

TEMPERATURE OPERATING RANGE: -10 to 186°C

UK END CONNECTION: Taper threaded to BS EN 10226-2 (ISO 7-1) formerly BS 21

US END CONNECTION: ANSI B1.20.1 (please add suffix AT to denote American Thread)

OPERATOR: T-Handle / Allen Key

SPECIFICATION: Quarter Turn, Tight Shut-off.

This valve is not suitable for use on Group 1 gases or unstable fluids, as defined by the Pressure Equipment Directive 2014/68/EU.*

* See page 155 for more information

Every effort has been made to ensure that the information contained in this publication is accurate at the time of publishing. Crane Ltd assumes no responsibility or liability for typographical errors or omissions or for any misinterpretation of the information within the publication and reserves the right to change without notice.

D171C

Compression Ended Bronze Ball Valve



D171C

D171CEXS

Compression Ended Bronze Ball Valve with Extension Stem

PN16

Features & Benefits

- Designed to be light, compact and easy to install and operate
- WRAS approved for use on hot and cold water systems up to 85°C
- Features improved leak resistance and reduced risk of damage from over tightening.

Materials

PART	MATERIAL	SIZES
Body	Bronze BS EN 1982 CC491K	All
Seat Retainer	Bronze BS EN 1982 CC491K	All
Ball	DZR Brass BS EN 12165 CW602N (Chrome plated)	All
Seat Ring	PTFE	All
Stem	DZR Brass BS EN 12164 CW602N	All
Packing	PTFE	All
Gland Nut	Brass BS EN 12164 CW617N	All
Lever	Mild Steel (Zinc Plated)	D171C
Screw	Mild Steel (Zinc Plated)	D171C
Lever Cover	PVC	D171C
Compression Olive	Brass BS EN 12449 CW505L/CW507L	All
Compression Nut	DZR Brass BS EN 12165 CW617N	All
Extension Housing	Aluminium	D171CEXS
Extension Stem	DZR Brass BS EN 12164 CW602N	D171CEXS

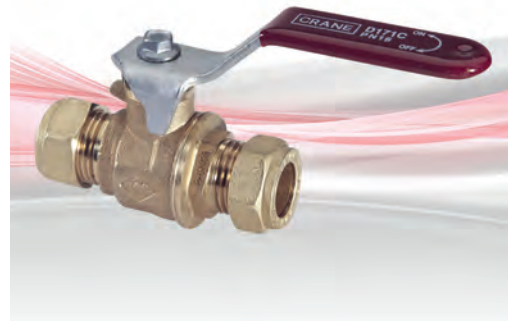

D171CEXS

Dimensional Drawing

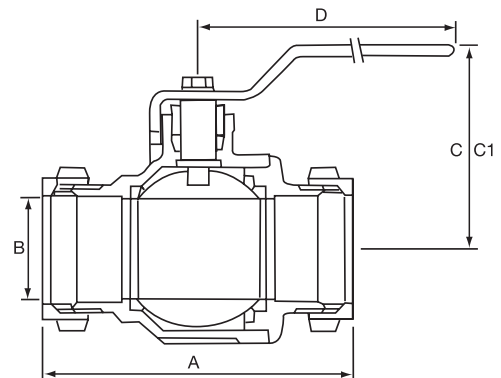

All dimensions are nominal.

Dimensions & Weights

SIZE (mm)	WEIGHT (kg)	A (mm)	B (mm)	C (mm)	C1 (mm) D171CEXS	D (mm)
15	0.27	80	15	40	97	92
22	0.51	84	20	58	98	92
28	0.78	95	25	65	118	127
35	1.19	111	32	70	124	127
42	1.82	124	40	83	142	142
54	3.28	149	50	91	149	142

Pressure/Temperature Ratings

Compression

TEMPERATURE (°C)	-10 to 30	65	120
PRESSURE (BAR)	16	10	5

Intermediate pressure ratings shall be determined by interpolation.

PRESSURE RATING: PN16

TEMPERATURE OPERATING RANGE: -10 to 120°C

UK END CONNECTION: Compression end to suit BS EN 1057: Half Hard R250 copper tube

OPERATOR: Lever

SPECIFICATION: Quarter Turn, Tight Shut-off.

This valve is intended for Group 2 liquids as defined by the Pressure Equipment Directive 2014/68/EU.*

* See page 155 for more information

D171A

Threaded DZR Ball Valve



D171A

D171AEXS

Threaded DZR Ball Valve with Extension Stem

PN25

Features & Benefits

- Designed to be light, compact and easy to install and operate
- Features improved leak resistance and reduced risk of damage from over tightening
- WRAS Approved to 85°C

Materials

PART	MATERIAL	QUANTITY
Hex-Nut	Steel Plated	1
Lever	Steel Dacromet Plated	1
Sleeve	Maroon PVC	1
Packing Nut	Brass BS EN 12164 CW617N	1
Packing Gland	PTFE WRAS approved	1
Body	DZR Brass BS EN 12165 CW602N	1
Seats	PTFE WRAS approved	2
Ball	DZR Brass Chrome Plated BS EN 12165 CW602N	1
O-Ring	Rubber EPDM WRAS approved	1
Seat Retainer	DZR Brass BS EN 12165 CW602N	1
Stem	DZR Brass BS EN 12164 CW602N	1
Extension Stem Outer	Aluminium	1
Extension Stem Inner	Steel Plated	1

Dimensions & Weights

SIZE (inch)	WEIGHT (kg) A	WEIGHT (kg) AEXS	L (mm)	L1 (mm)	L2 (mm) A	H (mm) A	H (mm) AEXS
1/4	0.152	-	45.3	12	89	41	-
3/8	0.136	-	45.3	12	89	41	-
1/2	0.205	0.270	58.5	15.5	98.5	48	103
3/4	0.302	0.366	67	17	98.5	51	107
1	0.511	0.589	80.5	21	125	62	116
1 1/4	0.811	0.930	94	23	140	77.5	129
1 1/2	1.101	1.219	102	23	140	83.5	135
2	1.808	1.953	124	26.5	165	97.5	150



D171AEXS

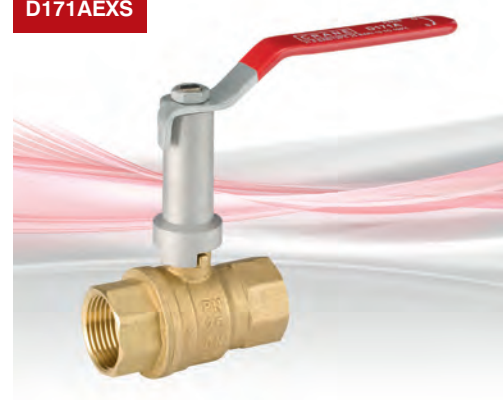

Dimensional Drawing

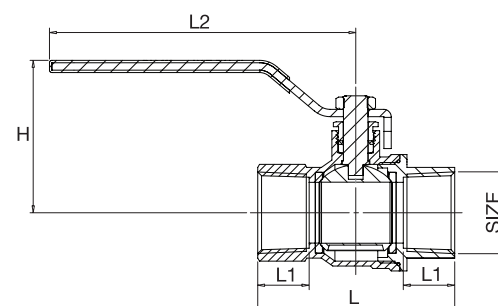

All dimensions are nominal.

Pressure/Temperature Ratings

Threaded

TEMPERATURE (°C)	-10 to 100	120
PRESSURE (BAR)	25	21.8

Intermediate pressure ratings shall be determined by interpolation.

PRESSURE RATING: PN25

TEMPERATURE OPERATING RANGE: -10 to 120°C

UK END CONNECTION: Taper threaded to BS EN 10226-2 (ISO 7-1) formerly BS 21

US END CONNECTION: ANSI B1.20.1:1983 (please add suffix AT to denote American Thread)

OPERATOR: Lever

SPECIFICATION: Quarter Turn

Valid as of 290719

Every effort has been made to ensure that the information contained in this publication is accurate at the time of publishing. Crane Ltd assumes no responsibility or liability for typographical errors or omissions or for any misinterpretation of the information within the publication and reserves the right to change without notice.

D171ATH

Threaded DZR Ball Valve with T-Handle



D171ALS

Threaded DZR Ball Valve with Lockshield

PN25

Features & Benefits

- Designed to be light, compact and easy to install and operate
- Crane's next generation DZR ball valve is WRAS Approved to 85°C
- Features improved leak resistance and reduced risk of damage from over tightening.

Materials

PART	MATERIAL	QUANTITY
Hex-Nut	Steel Plated	1
T-Handle	Aluminium AL-46100 Maroon	1
Packing Nut	Brass CW617N	1
Packing Gland	PTFE WRAS approved	1
Body	DZR Brass CW602N	1
Seats	PTFE WRAS approved	2
Ball	DZR Brass CW602N Chrome Plated	1
O-Ring	Rubber EPDM WRAS approved	1
Bonnet	DZR Brass CW602N	1
Stem	DZR Brass CW602N	1
Lockshield	Brass CW617N	1
Lockshield Cover	Polypropylene Maroon	1

Dimensions & Weights

SIZE (inch)	WEIGHT (kg) ATH	WEIGHT (kg) ALS	L (mm)	L1 (mm)	L2 (mm) ATH	H (mm) ATH	H (mm) ALS
1/2	0.183	0.207	59	15.5	50	40	42
3/4	0.277	0.302	67	17	50	43	45
1	0.470	0.506	80.5	21	55	54	58
1 1/4	0.809	0.867	94	23	82	61	67
1 1/2	1.210	1.269	102	23	82	67	73.5
2	2.106	2.166	124	26.5	110	80.5	86.5



D171ATH

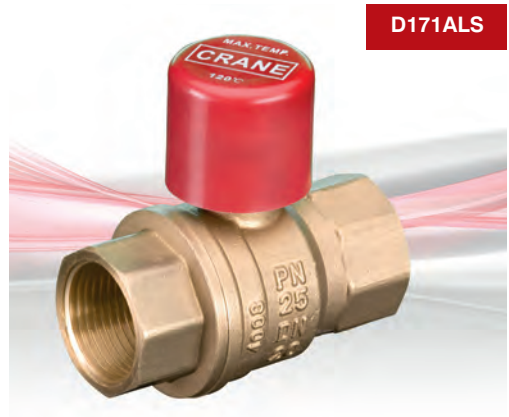

D171ALS

Dimensional Drawing

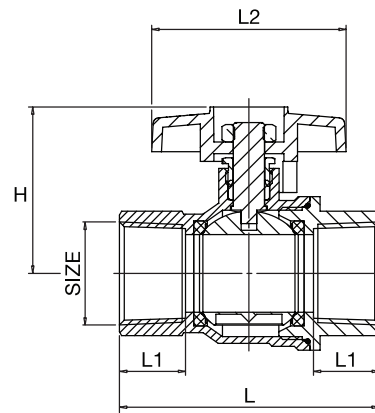

Pressure/Temperature Ratings

Threaded

TEMPERATURE (°C)	-10 to 100	120
PRESSURE (BAR)	25	21.8

Intermediate pressure ratings shall be determined by interpolation.

PRESSURE RATING: PN25

TEMPERATURE OPERATING RANGE: -10 to 120°C

UK END CONNECTION: Taper threaded to BS EN 10226-2 (ISO 7-1) formerly BS 21

US END CONNECTION: ANSI B1.20.1:1983 (please add suffix AT to denote American Thread)

OPERATOR: T-Handle / Spanner or Socket

SPECIFICATION: Quarter Turn

Every effort has been made to ensure that the information contained in this publication is accurate at the time of publishing. Crane Ltd assumes no responsibility or liability for typographical errors or omissions or for any misinterpretation of the information within the publication and reserves the right to change without notice.

D171AC

Compression DZR Ball Valve



D171AC

D171ACEXS

Compression DZR Ball Valve with Extension Stem

PN16

Features & Benefits

- Designed to be light, compact and easy to install and operate
- WRAS Approved to 99°C

Materials

PART	MATERIAL	QUANTITY
Hex-Nut	Steel Plated	1
Lever	Steel Dacromet Plated	1
Handle Sleeve	Maroon PVC	1
Packing Nut	Brass CW617N	1
Packing Gland	PTFE WRAS approved	1
Body	DZR Brass CW602N	1
Seats	PTFE WRAS approved	2
Ball	DZR Brass CW602N Chrome Plated	1
Bonnet	DZR Brass CW602N	1
Compression Olive	Brass BS EN 12449 CW505L/CW507L	2
Compression Nut	DZR Brass BS EN 12165 CW617N	2
Stem	DZR Brass CW602N	1
Extension Stem Outer	Aluminium	1
Extension Stem Inner	Steel Plated	1



D171ACEXS



GENERAL VALVES

Dimensional Drawing

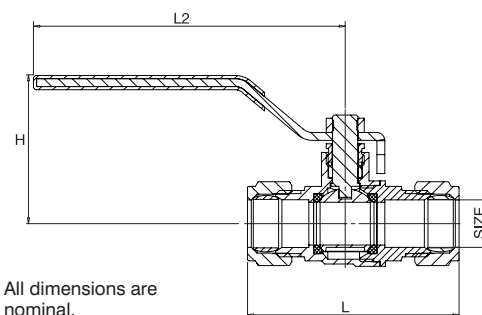

All dimensions are nominal.

Dimensions & Weights

SIZE (mm)	WEIGHT (kg) AC	WEIGHT (kg) ACEXS	L (mm) AC	L2 (mm) AC	H (mm) AC	H (mm) ACEXS
15	0.212	0.275	66.5	98.5	47	103
22	0.368	0.429	80	98.5	51	107
28	0.608	0.682	92.5	125	62	116
35	0.928	1.125	104.5	140	77.5	129
42	1.345	1.667	122	140	83	135
54	2.108	2.683	141	165	97.5	150

Pressure/Temperature Ratings

Threaded

TEMPERATURE (°C)	-10 to 30	65	120
PRESSURE (BAR)	16	10	5

Intermediate pressure ratings shall be determined by interpolation.

PRESSURE RATING: PN16

TEMPERATURE OPERATING RANGE: -10 to 120°C

UK END CONNECTION: Compression ends to suit BS EN 1057: Half hard R250 copper tube

OPERATOR: Lever

SPECIFICATION: Quarter Turn

Valid as of 290719

Every effort has been made to ensure that the information contained in this publication is accurate at the time of publishing. Crane Ltd assumes no responsibility or liability for typographical errors or omissions or for any misinterpretation of the information within the publication and reserves the right to change without notice.

D171ACTH

Compression DZR Ball Valve with T-Handle



D171ACLS

Compression DZR Ball Valve with Lockshield

PN16

Features & Benefits

- Designed to be light, compact and easy to install and operate
- WRAS Approved to 99°C



D171ACTH



D171ACLS

Materials

PART	MATERIAL	QUANTITY
Hex-Nut	Steel Plated	1
T-Handle	Aluminium AL-46100 Maroon	1
Packing Nut	Brass CW617N	1
Packing Gland	PTFE WRAS approved	1
Body	DZR Brass CW602N	1
Seats	PTFE WRAS approved	2
Ball	DZR Brass CW602N Chrome Plated	1
Bonnet	DZR Brass CW602N	1
Compression Olive	Brass BS EN 12449 CW505L/CW507L	2
Compression Nut	DZR Brass BS EN 12165 CW617N	2
Stem	DZR Brass CW602N	1
Lockshield	Brass CW617N	1
Lockshield Cover	Polypropylene Maroon	1

Dimensions & Weights

SIZE (mm)	WEIGHT (kg) ACTH	WEIGHT (kg) ACLS	L (mm)	L2 (mm) ACTH	H (mm) ACTH	H (mm) ACLS
15	0.187	0.220	66.5	50	40	42
22	0.343	0.376	80	50	43	47
28	0.567	0.614	92.5	55	54	59.5
35	0.977	0.984	104.5	82	61	67
42	1.487	1.522	122	82	67	73.5
54	2.364	2.467	141	110	80.5	87.5

Dimensional Drawing

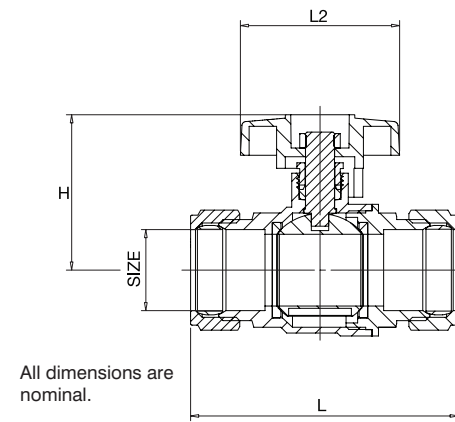

Pressure/Temperature Ratings

Threaded

TEMPERATURE (°C)	-10 to 30	65	120
PRESSURE (BAR)	16	10	5

Intermediate pressure ratings shall be determined by interpolation.

PRESSURE RATING: PN16

TEMPERATURE OPERATING RANGE: -10 to 120°C

UK END CONNECTION: Compression ends to suit BS EN 1057: Half hard R250 copper tube

OPERATOR: T-Handle / Spanner or Socket

SPECIFICATION: Quarter Turn

Valid as of 290719

Every effort has been made to ensure that the information contained in this publication is accurate at the time of publishing. Crane Ltd assumes no responsibility or liability for typographical errors or omissions or for any misinterpretation of the information within the publication and reserves the right to change without notice.

D171MHU

Bronze Draw-Off Valve



D171MHU

D171MHULS

Bronze Draw-Off Ball Valve with Lockshield

PN25

Features & Benefits

- Designed to be light, compact and easy to install and operate
- WRAS approved for use on hot and cold water systems up to 85°C
- Features improved leak resistance and reduced risk of damage from over tightening.

Materials

PART	MATERIAL	SIZES
Body	Bronze BS EN 1982 CC491K	All
Seat Retainer	Bronze BS EN 1982 CC491K	All
Ball	DZR Brass BS EN 12165 CW602N-Chrome Plated	All
Seat	PTFE	All
Stem	DZR Brass BS EN 12164 CW602N	All
Packing	PTFE	All
Gland Nut	Brass BS EN 12164 CW617N	All
Lever	Mild Steel (Zinc Plated)	D171MHU
Lever Screw	Mild Steel (Zinc Plated)	D171MHU
Lever Cover	PVC	D171MHU
Hose Connector	Brass BS EN 12164 CW617N	All
Hose Union Nut	Brass BS EN 12165 CW617N	All
Washer	PTFE	All
Lockshield Cap	Brass BS EN 12164 CW617N	D171MHULS
Lockshield Cover	Nylon 6	D171MHULS

Dimensions & Weights

SIZE (inch)	WEIGHT (kg)	A (mm)	B (mm)	C (mm)	C1 (mm) D171MHULS	D (mm)	D1 (mm) D171MHULS
1/2	0.27	104	15	40	47	82	36
3/4	0.55	124	20	58	51	92	36
1	0.88	147	25	65	58	127	39



D171MHULS



Dimensional Drawing

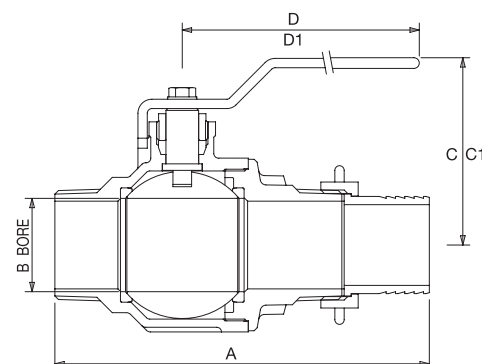

Pressure/Temperature Ratings

TEMPERATURE (°C)	-10 to 100	110	120	186
PRESSURE (BAR)	25.0	23.4	21.8	10.5

Intermediate pressure ratings shall be determined by interpolation.

PRESSURE RATING: PN25

TEMPERATURE OPERATING RANGE: -10 to 186°C

UK END CONNECTION: Taper threaded to BS EN 10226-2 (ISO 7-1) formerly BS 21

OPERATOR: Lever / Allen Key

SPECIFICATION: Quarter Turn, Tight Shut-off. Male x hose union outlet.

This valve is not suitable for use on Group 1 gases and unstable fluids as defined by the Pressure Equipment Directive 2014/68/EU.*

* See page 155 for more information

D171CT

Compression Ended T-Handle Ball Valve



D171CT



D171CLS

Compression Ended Lockshield Ball Valve

PN16

D171CLS



Features & Benefits

- Designed to be light, compact and easy to install and operate
- WRAS approved for use on hot and cold water systems up to 85°C
- Features improved leak resistance and reduced risk of damage from over tightening.

Materials

PART	MATERIAL	SIZES
Body	Bronze BS EN 1982 CC491K	All
Seat Retainer	Bronze BS EN 1982 CC491K	15 - 28
Seat Retainer	Bronze BS EN 1982 CC491K	35 - 54
Ball	DZR Brass BS EN 12165 CW602N	All
Seat	PTFE	All
Stem	DZR Brass BS EN 12164 CW602N	All
Packing	PTFE	All
Gland Nut	Brass BS EN 12164 CW617N	All
T-Handle	Aluminium	D171CT
Screw	Steel (Zinc Plated)	D171CT
Compression Olive	Brass BS EN 12449 CW505L/CW507L	All
Compression Nut	DZR Brass BS EN 12165 CW617N	All
Lockshield	Brass BS 2872	D171CLS
Lockshield Cover	Nylon 6	D171CLS

Dimensions & Weights

SIZE (mm)	WEIGHT (kg)	A (mm)	B (mm)	C (mm)	C1 (mm) D171LCS	D (mm)	D1 (mm) D171CLS
15	0.25	80	15	42	48	55	29
22	0.47	84	20	43	51	55	36
28	0.73	95	25	53	58	83	39

Dimensional Drawing

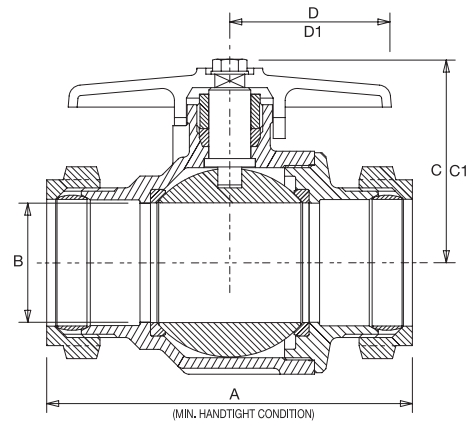

Pressure/Temperature Ratings

Compression

TEMPERATURE (°C)	-10 to 30	65	120
PRESSURE (BAR)	16	10	5

Intermediate pressure ratings shall be determined by interpolation.

PRESSURE RATING: PN16

TEMPERATURE OPERATING RANGE: -10 to 120°C

UK END CONNECTION: Compression ends to suit BS EN 1057: Half hard R250 copper tube

OPERATOR: T-Handle / Allen Key

SPECIFICATION: Quarter Turn, Tight Shut-off.

This valve is intended for Group 2 liquids as defined by the Pressure Equipment Directive 2014/68/EU.*

* See page 155 for more information

D181C

Service Ball Valve



PN16

D181C



GENERAL VALVES

Features & Benefits

- Light, compact and easy to install and operate
- WRAS approved for use on wholesome (potable) water
- Compression ends to BS EN 1254-2 for use with BS EN 1057 R250
- Chrome plated finish
- Handle can be removed to allow for screwdriver operation

Materials

PART	MATERIAL	SPECIFICATION	QUANTITY
Screw	Steel	Dacromet Plated	1
Handle	Nylon (Ral 9017)		1
Stem	DZR Brass	Chromium Plated	1
O-Ring	EPDM	WRAS approved	1
Nut	DZR Brass	CW602N Chromium Plated	2
Olive	Brass	CW507L	
Body	DZR Brass	CW602N Chromium Plated	
PTFE Seat	PTFE	WRAS approved	
Ball	DZR Brass	CW602N Chromium Plated	
Seat Retainer	DZR Brass	CW602N Chromium Plated	1

Dimensional Drawing

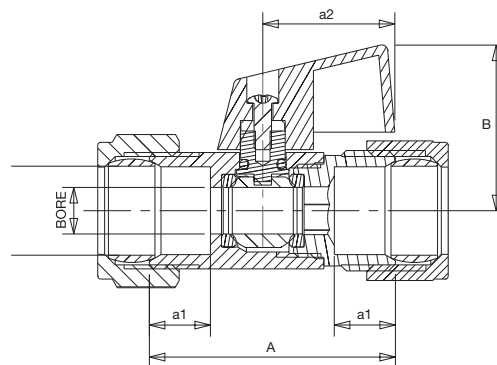

Dimensions & Weights

SIZE (mm)	BORE (mm)	A (mm)	a1 (mm)	a2 (mm)	B (mm)	WEIGHT (kg)
DN15	ø8	42	10.5	23	28.3	0.124
DN22	ø13.5	53	12.5	23	33.1	0.268

Pressure/Temperature Ratings

TEMPERATURE (°C)	-10 to 30	65	110	120
PRESSURE (BAR)	16	10	6	5

Intermediate pressure ratings shall be determined by interpolation.

PRESSURE RATING: PN16

OPERATOR: Handle.

The handle can be removed to allow for screwdriver operation.

SPECIFICATION: Compression ends to BS EN 1254-2 for use with BS EN 1057 R250 (half-hard) copper tube. WRAS approved product.

D191

D191

Threaded DZR Ball Valve

PN25

Features & Benefits

- Designed to be light, compact and easy to install and operate
- Features improved leak resistance and reduced risk of damage from over tightening
- Tested by BSI and complies with essential requirements of BS EN 331:1998
- Also suitable for natural gas applications

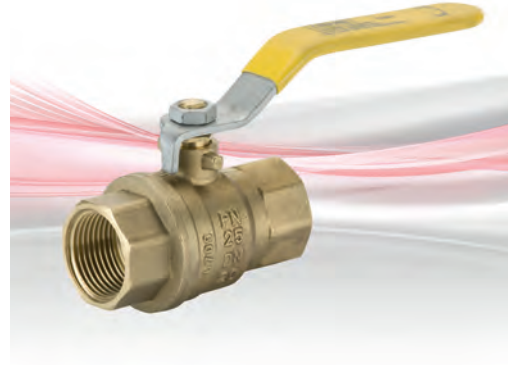

Materials

PART	MATERIAL	QUANTITY
Hex-Nut	Dacromet Plated Steel	1
Handle Sleeve	PVC Yellow	1
Handle	Dacromet Plated Steel	1
Packing Nut	Brass CW617N	1
Packing Gland	PTFE (WRAS Approved)	1
Body	DZR Brass CW602N	1
Ball	DZR Brass Chrome Plated	1
Seats	PTFE (WRAS Approved)	2
O-Ring	NBR with BS EN 549 Approval	1
Bonnet	DZR Brass CW602N	1
Stem	DZR Brass CW602N	1

Dimensional Drawing

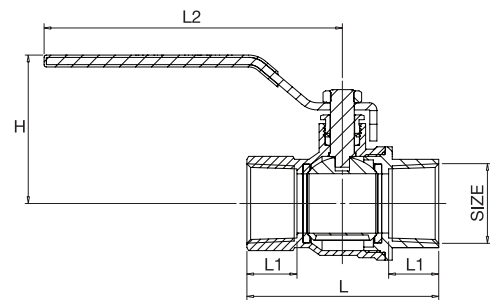

All dimensions are nominal.

Dimensions & Weights

SIZE (inch)	WEIGHT (kg)	L (mm)	L1 (mm)	L2 (mm)	H (mm)
1/4	0.152	46	12	89	41
3/8	0.136	46	12	89	41
1/2	0.205	59	15.5	98.5	48
3/4	0.302	67	17	98.5	51
1	0.511	80.5	21	125	63
1 1/4	0.890	94	23	140	78
1 1/2	1.292	102	23	140	83.5
2	2.238	124	26.5	165	97.5

Pressure/Temperature Ratings

Non Gas application

TEMPERATURE (°C)	-10 to 100	110
PRESSURE (BAR)	25	23.5

Intermediate pressure ratings shall be determined by interpolation.

Natural Gas application

TEMPERATURE (°C)	-20 to 60
PRESSURE (BAR)	5

Intermediate pressure ratings shall be determined by interpolation. Gas approved to BS EN 331:1998

PRESSURE RATING: PN25

TEMPERATURE OPERATING RANGE: Non Gas -10 to 110°C, Gas -20 to 60°C

UK END CONNECTION: Taper threaded to BS EN 10226-2 (ISO 7-1) formerly BS 21

US END CONNECTION: ANSI B1.20.1:1983 (please add suffix AT to denote American Thread)

OPERATOR: Lever

SPECIFICATION: Quarter Turn, PTFE Seats and Stem Seal.

Tested by BSI and complies with the essential requirements of BS EN 331:1998.

PROJECT

Mall of Egypt



Crane Fluid Systems has supplied a range of general valves to the Mall of Egypt, a five star complex which includes a ski dome.

The mall is comprised of 160,000 square meters of retail space with more than 400 shops and over 50 food and beverage outlets.

It is set to be the dominant super mall serving the western half of the city as a 'one stop' destination for locals and tourists.

Opened in March 2017, the mall is a sister brand to Mall of the Emirates, combining a powerful range of retailers with the most comprehensive leisure offering in North Africa.

Crane Fluid Systems valves have been used throughout the HVAC systems, and importantly in the Ski Egypt ski dome – keeping the air conditioning fully functional.

Majid Al Futtaim is a real estate developer which specialises in the operation of shopping malls in the Middle East and North Africa. Majid Al Futtaim also oversaw Ski Dubai, a large ski dome which brings the first real and complete winter experience to the Middle East.

LOCATION:

Cairo, Egypt

DISTRIBUTOR:

Omega

CLIENT:

Majid Al Futtaim

SPECIFICATION:

Butterfly valves, ball valves, gate valves, globe valves, DRVs, strainers

CONTRACTOR:

ORASCOMS

Butterfly Valves

F614



Crane Fluid System butterfly valves are compact quarter turn valves. The body is elastomer lined providing a resilient bubble tight shut off. The valves are supplied in wafer or lugged variants and may be lever or gearbox operated. Linings are EPDM or Nitrile rubber depending on the intended service conditions. Primarily recommended for on off service, they may also be used for non-critical throttling applications. Only a quarter turn is needed to fully open or close the valve.

CFS also offer a range of high performance butterfly valves, developed for high integrity shut-off and regulation duties. This range is ideal where increased pressure and elevated temperature specifications are outside the normal operating parameters of concentric disc valves. The CFS high performance valves have enhanced features to provide impeccable performance and reliability.

Features & Benefits

Figure Number	BODY			DISC		SHAFT	LINER / BODY SEAL				BODY STYLE		OPERATOR	RATING								
	Size Range	Ductile Iron	Steel	Aluminium Bronze	Ductile Iron	Stainless Steel	Stainless Steel	EPDM	Nitrile	EPDM WRAS Approved	PTFE	Semi Lugged	Fully Lugged	Lever	Gearbox	PN10	PN16	PN25	PN40	ANSI Class 125	ANSI Class 150	
F611	50 - 200mm	✓		✓			✓	✓			✓		✓			✓						
F612	50 - 600mm	✓		✓			✓	✓			✓			✓		✓						
F621†	50 - 200mm	✓		✓			✓			✓	✓		✓			✓						
F622†	50 - 300mm	✓		✓			✓			✓	✓			✓		✓						
F614	50 - 200mm	✓		✓			✓	✓				✓	✓			✓						
F615	50 - 600mm	✓		✓			✓	✓				✓	✓			✓						
F624†	50 - 200mm	✓		✓			✓			✓		✓	✓			✓						
F625†	50 - 300mm	✓		✓			✓			✓		✓		✓		✓						
F626	50 - 200mm	✓		✓			✓		✓		✓		✓			✓						
F627	50 - 600mm	✓		✓			✓		✓		✓			✓		✓						
F628	50 - 200mm	✓		✓			✓		✓			✓	✓			✓						
F629	50 - 600mm	✓		✓			✓		✓			✓	✓			✓						
F631	50 - 200mm	✓				✓	✓	✓				✓	✓			✓						
F632	50 - 600mm	✓				✓	✓	✓				✓	✓			✓						
FM638	50 - 150mm	✓				✓	✓	✓				✓	✓				✓					✓
FM639	50 - 600mm	✓				✓	✓	✓				✓	✓				✓					✓
DM638	50 - 150mm	✓				✓	✓	✓				✓	✓				✓					
DM639	50 - 600mm	✓				✓	✓	✓				✓	✓				✓					
FM700 / FM701	700 - 1800mm	✓				✓	✓	✓				✓		✓	1400 - 1800 mm	700 - 1200 mm						
FA700 / FA701	26 - 56"	✓				✓	✓	✓				✓		✓					✓			✓
FA725G	700 - 900mm	✓				✓	✓	✓				✓	✓			✓						
FM725G	700 - 900mm	✓				✓	✓	✓				✓	✓				✓					

† WRAS approved product

Valid as of 03/02/20

F611 / F621 / F626

Semi-Lugged Lever Operated Butterfly Valves



F611

PN16

Features & Benefits

- Robust, ductile iron valve body for long life service
- Valve body semi-lugged to fit PN16 or ANSI Class 125 flanges
- The anti-blow out stem design provides a safe and secure operation
- Integrated notch plate for a more compact design and aluminium lever to reduce risk of corrosion
- Fully bonded epoxy paint system for superior corrosion resistance
- Suitable for applications where Level 3 C3 (Medium) corrosion protection is required
- Maintenance free valve design, reducing downtime
- Suitable for a wide temperature range -10°C to 130°C
- F621 - WRAS approved for potable water applications -10°C to 80°C



GENERAL VALVES

Materials

PART	MATERIAL
Body	Ductile Iron ASTM A536 64-45-12 (Epoxy Paint)
Disc	Aluminium Bronze C954 ASTM B148
Liner (F611)	Nitrile Temp. -10 to 90°C
Liner (F621)	EPDM (WRAS Approved) Temp. -10 to 100°C (80°C WRAS)
Liner (F626)	EPDM (High Temperature) Temp. -10 to 130°C
Shaft	Stainless Steel Type 410
Taper Pin	Stainless Steel Type 410
O-Ring	Buna-N
Bushing	PTFE
Lever	Aluminium Alloy (Epoxy Paint)

Dimensional Drawing

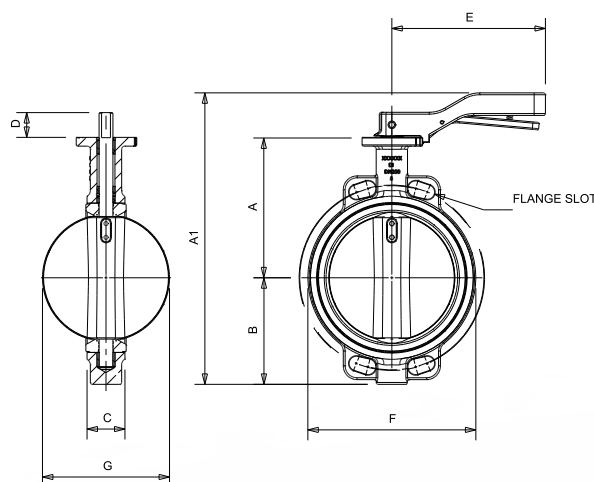

Dimensions & Weights

SIZE (mm)	WEIGHT (kg)	A (mm)	A1 (mm)	B (mm)	C (mm)	D (mm)	E (mm)	F (mm)	G (mm)	Kv	FLANGE SLOTS TO SUIT
50	2.4	109	246	72	43	32	212.5	100	52.9	98	DN50 PN16 / 2" CL125
65	3.3	131.5	278.5	82	46	32	212.5	120	64.6	167	DN65 PN16 / 2.1/2" CL125
80	3.6	134	294	95	46	32	212.5	127	79	258	DN80 PN16 / 3" CL125
100	4.5	163	343	115	52	32	212.5	156	104.4	512	DN100 PN16 / 4" CL125
125	6.3	169	359	125	56	32	212.5	190	123.5	872	DN125 PN16 / 5" CL125
150	8.4	179	392	142	56	40	245	212	155.8	1,347	DN150 PN16 / 6" CL125
200	13.4	224	465	170	60	40	378	268	202.7	2,675	DN200 PN16 / 8" CL125

Pressure/Temperature Ratings

	F611	F621	F626
MAX TEMP (°C)	-10 to 90	-10 to 100	-10 to 130
PRESSURE (BAR)	16	16	15.7

Intermediate pressure ratings shall be determined by interpolation.

WRAS approved -10 to 80°C

*Kv coefficient denotes valves in fully open position

PRESSURE RATING: PN16 / CLASS 125

TEST PRESSURES:

Shell: 24 Bar Seat: 17.6 Bar

SPECIFICATION: Lever operated epoxy coated Ductile Iron Body. Semi-lugged. Aluminium disc. EPDM or Nitrile liner. To suit flange connections BS EN 1092-2 PN10 or PN16 and ANSI B16.1 Class 125. Valves may be used for flow regulation. Valve design conforms to BS EN 593. Face to face conforms to BS EN 558.

MEDIUM:

F611 - Suitable for Group 1 and 2 gases and Group 1 and 2 liquids as defined by the Pressure Equipment Directive 2014/68/EU.*
 F621 - Suitable Group 2 liquids as defined by the Pressure Equipment Directive 2014/68/EU* WRAS approved valves.
 F626 - Suitable Group 2 liquids as defined by the Pressure Equipment Directive 2014/68/EU.*

* See page 155 for more information

Valid as of 220319

Every effort has been made to ensure that the information contained in this publication is accurate at the time of publishing. Crane Ltd assumes no responsibility or liability for typographical errors or omissions or for any misinterpretation of the information within the publication and reserves the right to change without notice.

F612 / F622 / F627 / F626B



Semi-lugged gearbox operated Butterfly Valves

PN16

F612



Features & Benefits

- Robust, ductile iron valve body for long life service
- The anti-blow out stem design provides a safe and secure operation
- Valve body semi-lugged to fit PN16 or ANSI Class 125 flanges
- Fully bonded epoxy paint system for superior corrosion resistance
- Suitable for applications where Level 3 C3 (Medium) corrosion protection is required
- Maintenance free valve design, reducing downtime
- Sizes 50-300mm are suitable for use with flanges conforming to BS EN 1092-2 PN10 or PN16 and ANSI B16.1 Class 125.
- Sizes 350-600mm are for PN16 flanges only
- F622 sizes 50-300mm are WRAS approved -10°C to 80°C

Materials

PART	MATERIAL
Body	Ductile Iron ASTM A536 64-45-12 (Epoxy Paint)
Disc	Aluminium Bronze C954 ASTM B148
Liner (F612)	Nitrile Temp. -10 to 90°C
Liner (F622)	EPDM (WRAS approved) Temp. -10 to 100°C (80°C WRAS)
Liner (F627/F626B)	EPDM (High Temperature) Temp. -10 to 130°C
Shaft	Stainless Steel Type 410
Taper Pin	Stainless Steel Type 410
O-Ring	Buna-N
Bushing	PTFE
Gearbox	Cast Iron

Dimensional Drawing

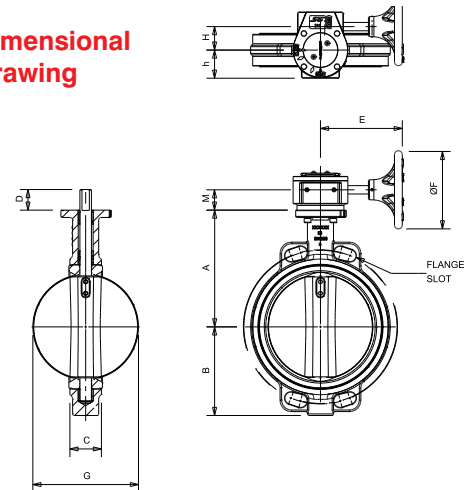

Pressure/Temperature Ratings

	F612	F622	F627/ F626B
MAX TEMPERATURE (°C)	-10 to 90	-10 to 100	-10 to 130
PRESSURE (BAR)	16	16	15.7

Intermediate pressure ratings shall be determined by interpolation. WRAS approved -10 to 80°C

Dimensions & Weights

SIZE (mm)	WEIGHT		A (mm)	B (mm)	C (mm)	D (mm)	E (mm)	F (mm)	G (mm)	H (mm)	h (mm)	M (mm)	Kv	FLANGE SLOTS TO SUIT
	BARESHAF VALVE	GEARBOX OPERATED												
50	2.1	7.1	109	72	43	32	157	150	52.9	45	54	39	98	DN50 PN16 / 2" CL125
65	3.0	7.9	131.5	82	46	32	157	150	64.6	45	54	39	167	DN65 PN16 / 2.1/2" CL125
80	3.2	8.2	134	95	46	32	157	150	79	45	54	39	258	DN80 PN16 / 3" CL125
100	4.2	9.1	163	115	52	32	157	150	104.4	45	54	39	512	DN100 PN16 / 4" CL125
125	6.0	10.9	169	125	56	32	157	150	123.5	45	54	39	872	DN125 PN16 / 5" CL125
150	7.8	12.7	179	142	56	40	157	150	155.8	45	54	39	1,347	DN150 PN16 / 6" CL125
200	12.7	19.6	224	170	60	40	238	150	202.7	45	54	39	2,675	DN200 PN16 / 8" CL125
250	28.4	38.8	264	215	68	40	238	300	250.7	63	81	41.5	4,555	DN250 PN16 / 8" CL125
300	41.0	54.0	299	240	78	40	223.5	300	301.9	78	81	38.3	7,037	DN300 PN16 / 12" CL125
350	-	56.2	368	264	78	-	223.5	300	334	78	81	46.5	6,003	DN350 PN16 / 14" CL125
400	-	88.4	400	305	86	-	277	450	390	78	81	39	8,885	DN400 PN16 / 16" CL125
450	-	110.0	422	317	105	-	325	450	441	185	160	120	10,419	DN450 PN16 / 18" CL125
500	-	160.5	479	352	130	-	325	450	492	185	160	120	13,613	DN500 PN16 / 20" CL125
600	-	260.0	562	444	154	-	340	450	597	185	160	126	17,801	DN600 PN16 / 24" CL125

*Kv coefficient denotes valves in fully open position

PRESSURE RATING: PN16 / ANSI CLASS 125

TEST PRESSURES:

Shell: 24 Bar Seat: 17.6 Bar

SPECIFICATION: Gearbox operated epoxy coated Ductile Iron Body. Semi-lugged. Aluminium disc. EPDM or Nitrile liner. To suit flange connections BS EN 1092-2 PN10 or PN16 and ANSI B16.1 Class 125. Valves may be used for flow regulation. Valve design conforms to BS EN 593. Face to face conforms to BS EN 558. Bareshaft option available, F626B 50-300mm.

MEDIUM:

F612 - Suitable for Group 1 and 2 gases and Group 1 and 2 liquids as defined by the Pressure Equipment Directive 2014/68/EU.*

F622 - Suitable Group 2 liquids as defined by the Pressure Equipment Directive 2014/68/EU* WRAS approved valves.

F627/F626B - Suitable Group 2 liquids as defined by the Pressure Equipment Directive 2014/68/EU.*

* See page 155 for more information

Valid as of 22/03/19

Every effort has been made to ensure that the information contained in this publication is accurate at the time of publishing. Crane Ltd assumes no responsibility or liability for typographical errors or omissions or for any misinterpretation of the information within the publication and reserves the right to change without notice.

F614/F624/F628

Fully-Lugged Lever Operated Butterfly Valves



F614

PN16

Features & Benefits

- Robust, ductile iron valve body for long life service
- Valve body semi-lugged to fit PN16 or ANSI Class 125 flanges
- The anti-blow out stem design provides a safe and secure operation
- Integrated notch plate for a more compact design and aluminium lever to reduce risk of corrosion
- Fully bonded epoxy paint system for superior corrosion resistance
- Suitable for applications where Level 3 C3 (Medium) corrosion protection is required
- Maintenance free valve design, reducing downtime
- Suitable for a wide temperature range -10°C to 130°C
- F624 - WRAS approved for potable water applications -10 to 80°C

Materials

PART	MATERIAL
Body	Ductile Iron ASTM A536 64-45-12 (Epoxy Paint)
Disc	Aluminium Bronze C954 ASTM B148
Liner (F614)	Nitrile Temp. -10 to 90°C
Liner (F624)	EPDM (WRAS Approved) Temp. -10 to 100°C (80°C WRAS)
Liner (F628)	EPDM (High Temperature) Temp. -10 to 130°C
Shaft	Stainless Steel Type 410
Taper Pin	Stainless Steel Type 410
O-Ring	Buna-N
Bushing	PTFE
Lever	Aluminium Alloy (Epoxy Paint)
Stop Plate	Carbon Steel (Zn Plated)

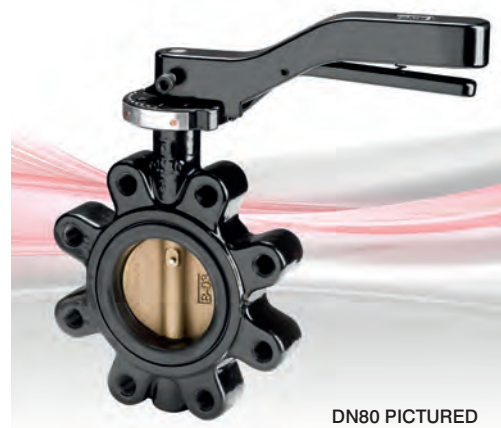

GENERAL VALVES

Dimensional Drawing

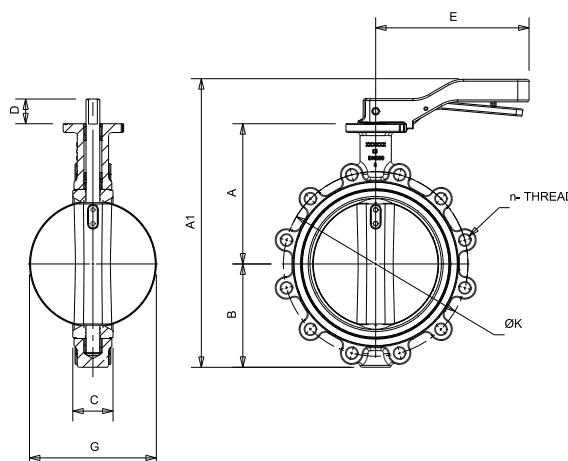

Dimensions & Weights

SIZE (mm)	WEIGHT (kg)	A (mm)	A1 (mm)	B (mm)	C (mm)	D (mm)	E (mm)	G (mm)	K (mm)	Kv	N-THREAD
50	3.6	109	246	72	43	32	212.5	52.9	125	98	4- M16x2.0
65	4.1	131.5	278.5	82	46	32	212.5	64.6	145	167	4- M16x2.0
80	5.0	134	294	90	46	32	212.5	79	160	258	8- M16x2.0
100	6.5	163	343	108	52	32	212.5	104.4	180	512	8- M16x2.0
125	9.3	169	359	125	56	32	212.5	123.5	210	872	8- M16x2.0
150	11.5	179	392	142	56	40	245	155.8	240	1,347	8-M20x2.5
200	16.8	224	465	165	60	40	378	202.7	295	2,675	12- M20x2.5

Pressure/Temperature Ratings

	F614	F624	F628
MAX TEMPERATURE (°C)	-10 to 90	-10 to 100	-10 to 130
PRESSURE (BAR)	16	16	15.7

Intermediate pressure ratings shall be determined by interpolation.

WRAS approved -10 to 80°C

*Kv coefficient denotes valves in fully open position

PRESSURE RATING: PN16

TEST PRESSURES:

Shell: 24 Bar Seat: 17.6 Bar

SPECIFICATION: Lever operated epoxy coated Ductile Iron Body. Semi-lugged. Aluminium or Stainless Steel disc. EPDM or Nitrile liner. To suit flange connections BS EN 1092-2 PN16. Valves may be used for flow regulation. Valve design conforms to BS EN 593. Face to face conforms to BS EN 558.

MEDIUM:

F614 - Suitable for Group 1 and 2 gases and Group 1 and 2 liquids as defined by the Pressure Equipment Directive 2014/68/EU.*

F624 - Suitable Group 2 liquids as defined by the Pressure Equipment Directive 2014/68/EU* WRAS approved valves.

F628 - Suitable Group 2 liquids as defined by the Pressure Equipment Directive 2014/68/EU.*

* See page 155 for more information

Valid as of 130319

Every effort has been made to ensure that the information contained in this publication is accurate at the time of publishing. Crane Ltd assumes no responsibility or liability for typographical errors or omissions or for any misinterpretation of the information within the publication and reserves the right to change without notice.

F615 / F625 / F629 / F628B



Fully-lugged gearbox operated Butterfly Valves

PN16



Features & Benefits

- Robust, ductile iron valve body for long life service
- Valve body fully-lugged for secure installation
- The anti-blow out stem design provides a safe and secure operation
- Fully bonded epoxy paint system for superior corrosion resistance
- Suitable for applications where Level 3 C3 (Medium) corrosion protection is required
- Maintenance free valve design, reducing downtime
- Suitable for a wide temperature range -10°C to 130°C
- F625 sizes 50-300mm are WRAS approved -10°C to 80°C

Materials

PART	MATERIAL
Body	Ductile Iron ASTM A536 (Epoxy Paint)
Disc	Aluminium Bronze
Liner (F615)	Nitrile Temp. -10 to 90°C
Liner (F625)	EPDM (WRAS Approved) Temp. -10 to 100°C (80°C WRAS)
Liner (F629/F628B)	EPDM (High Temperature) Temp. -10 to 130°C
Shaft	Stainless Steel Type 410
Taper Pin	Stainless Steel Type 316
O-Ring	Buna-N
Bushing	PTFE
Gearbox	Cast Iron

Dimensional Drawing

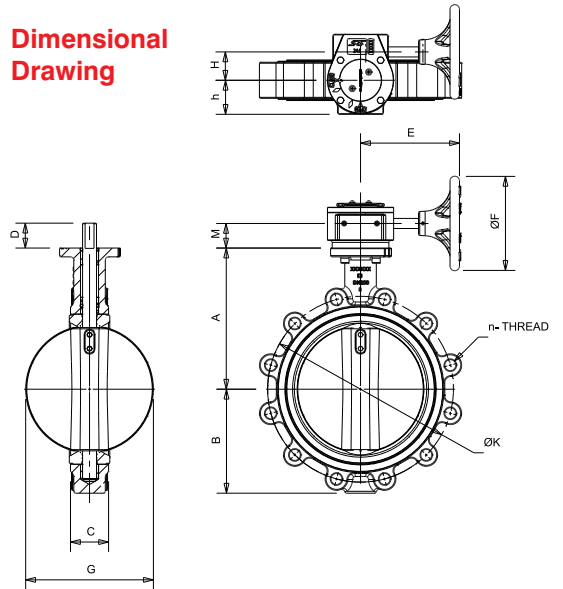

Pressure/Temperature Ratings

	F615	F625	F629/F628B
MAX TEMPERATURE (°C)	-10 to 90	-10 to 100	-10 to 130
PRESSURE (BAR)	16	16	15.7

Intermediate pressure ratings shall be determined by interpolation. WRAS approved -10 to 80°C

Dimensions & Weights

SIZE (mm)	WEIGHT (kg)		A (mm)	B (mm)	C (mm)	D (mm)	E (mm)	F (mm)	G (mm)	H (mm)	h (mm)	M (mm)	Kv	N- THREAD
	BARESHAF VALVE	GEARBOX OPERATED												
50	3.3	8.3	109	72	43	32	157	150	52.9	45	54	39	98	4- M16x2.0
65	3.8	8.7	131.5	82	46	32	157	150	64.6	45	54	39	167	4- M16x2.0
80	4.7	9.7	134	90	46	32	157	150	79	45	54	39	258	8- M16x2.0
100	6.2	11.2	163	108	52	32	157	150	104.4	45	54	39	512	8- M16x2.0
125	8.9	13.9	169	125	56	32	157	150	123.5	45	54	39	872	8- M16x2.0
150	11.0	15.8	179	142	56	40	157	150	155.8	45	54	39	1,347	8- M20x2.5
200	16.1	23.0	224	165	60	40	238	150	202.7	45	54	39	2,675	12- M20x2.5
250	34.5	44.9	264	215	68	40	238	300	250.7	63	81	41.5	4,555	12- M24x3.0
300	51.2	64.2	299	240	78	40	223.5	300	301.9	78	81	38.3	7,037	12- M24x3.0
350	-	226.0	368	264	78	-	223.5	300	334	78	81	46.5	6,003	12- M24x3.0
400	-	277.0	400	299	86	-	277	450	390	78	81	39	8,885	16- M27x3.0
450	-	277.0	422	317.5	105	-	325	450	441	185	160	120	10,419	16- M27x3.0
500	-	332.0	479	352.5	130	-	325	450	492	185	160	120	13,613	20- M30x3.5
600	-	357.0	562	444	154	-	340	450	597	185	160	126	17,801	20- M33x3.5

*Kv coefficient denotes valves in fully open position

PRESSURE RATING: PN16

TEST PRESSURES:

Shell: 24 Bar Seat: 17.6 Bar

SPECIFICATION: Gearbox operated epoxy coated Ductile Iron Body. Semi-lugged. Aluminium or Stainless Steel disc. EPDM or Nitrile liner. To suit flange connections BS EN 1092-2 PN16. Valves may be used for flow regulation. Valve design conforms to BS EN 593. Face to face conforms to BS EN 558. Bareshaft option available, F628B 50-300mm.

MEDIUM:

F615 - Suitable for Group 1 and 2 gases and Group 1 and 2 liquids as defined by the Pressure Equipment Directive 2014/68/EU.*

F625 - Suitable Group 2 liquids as defined by the Pressure Equipment Directive 2014/68/EU* WRAS approved valves.

F628B / F629 - Suitable Group 2 liquids as defined by the Pressure Equipment Directive 2014/68/EU.*

* See page 155 for more information

FM638 & FM639

Fully Lugged Butterfly Valve

PN25

FM639



GENERAL VALVES

Features & Benefits

- Robust, ductile Iron valve bodies for long service life
- Stainless steel disc for improved strength and a wide range of applications
- Suitable for wide temperature range -10°C to 120°C
- Extended size range for application requirements
- Fully lugged for secure installation
- Rated PN25 for higher pressure applications
- Lever (FM638) and Gearbox (FM639) options available

Materials

NO.	PART	MATERIAL	SPECIFICATION	SIZE
1	Body	DI (EN-GJS-400-15)	ASTM A536 65-45-12	DN50 - DN300
1	Body	Ductile Iron	EN-GJS-450-10	DN350 - DN600
2	Disc	Stainless Steel 304	ASTM A351 CF8	
3	Shaft	Stainless Steel 431	ASTM A276 431	DN50 - DN300
3	Shaft	Stainless Steel 630	ASTM A564 630	DN350 - DN600
4	Short Bushing	Aluminum Bronze	ASTM B148-952A	
5	Seat	EPDM	-	
6	Long Bushing	Aluminum Bronze	ASTM B148-952A	
7	Long Bushing	Aluminum Bronze	ASTM B148-952A	
8	'O' Ring	NBR	-	
9	Pin	Stainless Steel 431	ASTM A276 431	DN50 - DN300
9	Pin	Stainless Steel 630	ASTM A564 630	DN350 - DN600
10	Top Cap (FM638)	Carbon Steel	ASTM A194 Gr. 2H	
10	Hand Wheel (FM639)	-	-	
11	Bolt	Carbon Steel	ASTM A194 Gr. 2H	
12	Lever (FM638)	Malleable Iron	ASTM Gr. 32510	
12	Gear Box (FM639)	Cast Iron	EN-GJL-250	DN50 - DN300
12	Gear Box (FM639)	Ductile Iron	EN-GJS-450-10	DN350 - DN600

Dimensions & Weights

FM639 Geared Butterfly Valve											
SIZE (DN)	WEIGHT (KG)	A (mm)	B (mm)	C (mm)	ØD (mm)	N-M (mm)	ØDD (mm)	L1	L2	a°	Kv*
50	5.0	138	65	43	125	4-M16	150	173.5	249	45°	91
65	7.0	153	83	46	145	8-M16	150	173.5	264	22.5°	141
80	6.6	155	88	46	160	8-M16	150	173.5	266	22.5°	247
100	10.5	178	105.5	52	190	8-M20	150	173.5	289	22.5°	586
125	14.0	193	123	56	220	8-M24	150	173.5	304	22.5°	861
150	15.6	210	135	56	250	8-M24	150	173.5	321	22.5°	1839
200	28.6	240	172	60	310	12-M24	300	237	436	15°	2688
250	40.9	285.4	202	68	370	12-M27	300	237	481.5	15°	4576
300	58.2	315	234.5	78	430	16-M27	300	229.5	524	11.25°	7070
350	107	350	300	78	490	16-M30	300	254	610	11.25°	9404
400	153	385	330	102	550	16-M33	300	254	645	11.25°	11840
450	215	410	360	114	600	20-M33	400	301	738	9°	15217
500	279	435	400	127	660	20-M33	400	355	792	9°	18928
600	399	505	455	154	770	20-M36	400	355	862	9°	27545

*Kv data denotes valves at fully open position

PRESSURE/TEMPERATURE RATING: 25 Bar From -10°C To 120°C
MEDIUM: Group 2 Liquids only as defined by the Pressure Equipment Directive 2014/68/EU*
FLANGES: Fully Lugged to BS EN1092-2
FACE TO FACE: BS EN 558

Dimensional Drawing

FM638 Lever Butterfly Valve

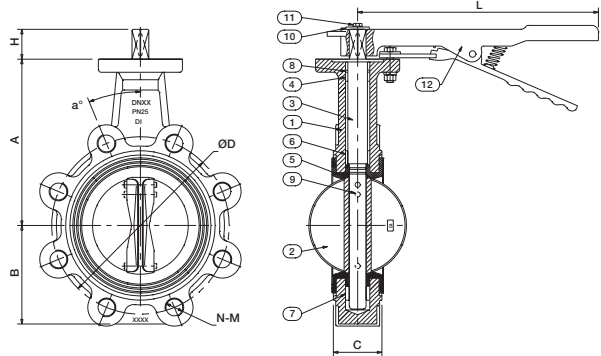

FM639 Gearbox Butterfly Valve

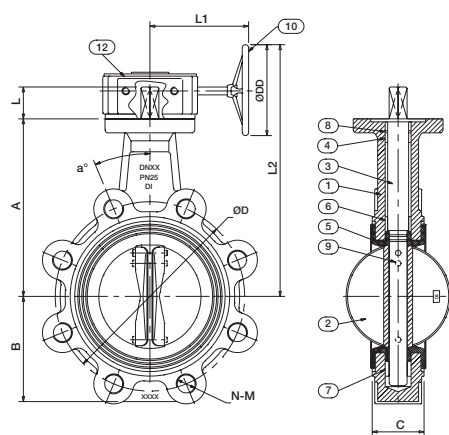

FM638 Lever Butterfly Valve

SIZE (DN)	WEIGHT (KG)	A (mm)	B (mm)	C (mm)	ØD (mm)	N-M (mm)	H (mm)	L (mm)	a°	Kv*
50	5.0	138	65	43	125	4-M16	32	216	45°	91
65	6.6	153	83	46	145	8-M16	32	216	22.5°	141
80	6.6	155	88	46	160	8-M16	32	216	22.5°	247
100	10.3	178	105.5	52	190	8-M20	32	265	22.5°	586
125	14.0	193	123	56	220	8-M24	32	265	22.5°	861
150	15.5	210	135	56	250	8-M24	32	265	22.5°	1839

DESIGN STANDARD: BS EN 593: 2009
TEST AND INSPECTION STANDARD: BS EN 12266-1
MOUNTING FLANGE: ISO 5211-2001

* See page 155 for more information

Valid as of 270220

Every effort has been made to ensure that the information contained in this publication is accurate at the time of publishing. Crane Ltd assumes no responsibility or liability for typographical errors or omissions or for any misinterpretation of the information within the publication and reserves the right to change without notice.

FM700 / FM701 & FM700B

FM700

DN700 - DN1200
DN1400 - DN1800

PN16
PN10



Features & Benefits

- Manufactured to BS EN 593: 2009
- Complies with Pressure Equipment Directive 2014/68/EU
- Suitable for Gearbox or Actuator operation
- Rugged construction: Ductile Iron Body for all sizes
- Stainless Steel disc as standard
- Epoxy paint coated as standard
- Low operating torques

Materials

NO.	PART	MATERIAL	SPECIFICATION
1	Key	Carbon Steel	ASTM A29 1045
2	Screw	Carbon Steel	ASTM A194 Gr.2H
3	Short Bushing	-	PTFE
4	O' Ring	-	NBR
5	Upper Shaft	Stainless Steel	ASTM A276 420
6	Body	Ductile Iron	EN-GJS-500-7U
7	Long Bushing	-	PTFE
8	Seat + Backing Ring	-	EPDM + Aluminium
9	Disc: FM700/FM700B	Stainless Steel 316	ASTM A351 CF8M
	Disc: FM701	Stainless Steel 304	ASTM A351 CF8
10	Pin	Stainless Steel	ASTM A276 431
11	Lower Shaft	Stainless Steel	ASTM A276 420
12	Split Retaining Ring	Carbon Steel	ASTM A29-1045
13	Bearing	High Carbon Steel	ASTM A295 52100
14	Screw	Carbon Steel	ASTM A194 Gr. 2H
15	Lower Gland	Carbon Steel	EN-GJS-500-7U
16	Gearbox	Ductile Iron	EN-GJS-400-15

Dimensional Drawing

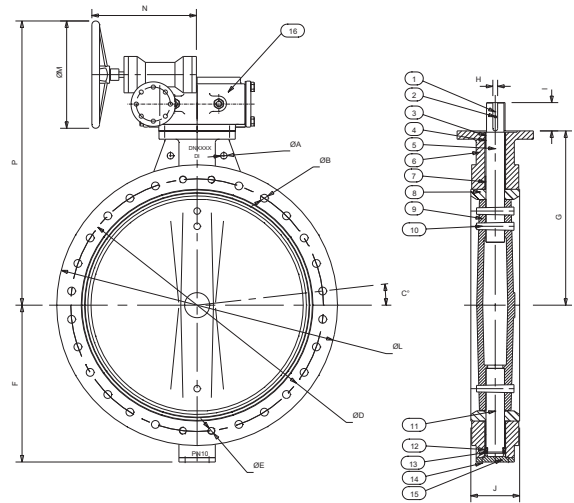

Dimensions & Weights

SIZE (DN)	A (mm)	B (mm)	C (mm)	D (mm)	E (mm)	F (mm)	G (mm)	H (mm)	I (mm)	J (mm)	K (mm)	L (mm)	M (mm)	N (mm)	P (mm)	FLANGE THICKNESS	WEIGHT (kg)		FLOW (kv)
																	Gearbox	Bareshaft	
DN700	N/A	20-Ø37	7.5	840	4-M33	537	629	18	110	165	4-Ø40	910	398	397	883	39.5	350	310	42818
DN800	N/A	20-Ø41	7.5	950	4-M36	596	666	20	110	190	4-Ø40	1025	500	417	971	43	450	410	33086
DN900	N/A	24-Ø41	6.43	1050	4-M36	656	720	20	110	203	4-Ø42	1125	500	450	1032	46.5	605	550	75688
DN1000	2-Ø40	24-Ø44	6.43	1170	4-M39	720	800	22	130	216	4-Ø45	1255	500	470	1109	50	810	740	103584
DN1200	2-Ø46	28-Ø50	5.625	1390	4-M45	864	942	28	130	254	N/A	1485	600	491	1327	57	1270	1130	133210
DN1400	2-Ø48	32-Ø44	5	1590	4-M39	1014	1000	40	180	279	N/A	1675	600	491	1385	46	1645	1510	152700
DN1600	2-Ø50	36-Ø50	4.5	1820	4-M45	1071	1155	40	180	318	N/A	1915	500	571	1685	49	3540	3200	175700
DN1800	2-Ø50	40-Ø50	4.09	2020	4-M45	1178	1300	45	200	356	N/A	2115	500	665	1853	52	5900	5310	211060

PRESSURE RATING: DN700 - DN1200 PN16, DN1400 - DN1800 PN10
TEMPERATURE RATING: -20°C to 120°C
FACE TO FACE DIMENSIONS: BS EN 558: 2011 Series 20
END CONNECTIONS: Flanges to BS EN 1092 PN10 and PN16
ACTUATOR MOUNTING FLANGES: ISO 5211: 2001

OPERATORS: Gearbox - FM700 - (Disc SS 316) / FM701 (Disc SS 304)
BARESHAF VALVE OPTIONS: FM700B

Valid as of 290719

Every effort has been made to ensure that the information contained in this publication is accurate at the time of publishing. Crane Ltd assumes no responsibility or liability for typographical errors or omissions or for any misinterpretation of the information within the publication and reserves the right to change without notice.

FA700 / FA701 & FA700B

FA700

26" – 56"

ANSI 150

Features & Benefits

- Manufactured to BS EN 593: 2009
- Complies with Pressure Equipment Directive 2014/68/EU
- Suitable for Gearbox or Actuator operation
- Rugged construction: Ductile Iron Body for all sizes
- Stainless Steel disc as standard
- Epoxy paint coated as standard
- Low operating torques



Materials

NO.	PART	MATERIAL	SPECIFICATION
1	Key	Carbon Steel	ASTM A29 1045
2	Screw	Carbon Steel	ASTM A194 Gr.2H
3	Short Bushing	-	PTFE
4	O' Ring	-	NBR
5	Upper Shaft	Stainless Steel	ASTM A276 420
6	Body	Ductile Iron	EN-GJS-500-7U
7	Long Bushing	-	PTFE
8	Seat + Backing Ring	-	EPDM + Aluminium
9	Disc: FA700/FA700B	Stainless Steel 316	ASTM A351 CF8M
	Disc: FA701	Stainless Steel 304	ASTM A351 CF8
10	Pin	Stainless Steel	ASTM A276 431
11	Lower Shaft	Stainless Steel	ASTM A276 420
12	Split Retaining Ring	Carbon Steel	ASTM A29-1045
13	Bearing	High Carbon Steel	ASTM A295 52100
14	Screw	Carbon Steel	ASTM A194 Gr. 2H
15	Lower Gland	Carbon Steel	EN-GJS-500-7U
16	Gearbox	Ductile Iron	EN-GJS-400-15

Dimensional Drawing

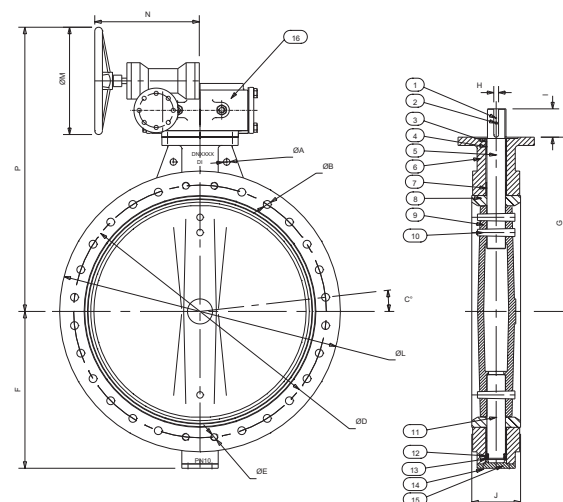

Dimensions & Weights

SIZE (inch)	A (mm)	B (mm)	C (mm)	D (mm)	E (mm)	F (mm)	G (mm)	H (mm)	I (mm)	J (mm)	K (mm)	L (mm)	M (mm)	N (mm)	P (mm)	FLANGE THICKNESS	WEIGHT (kg)		FLOW (kv)
																	Gearbox	Bareshaft	
26"	N/A	20-Ø35	7.5	806.5	4-1.25-7	485	565	14	110	165	N/A	870	600	346	913	39.5	307	270	37300
28"	N/A	24-Ø35	6.43	863.6	4-1.25-7	537	629	18	110	165	4-Ø40	927	398	397	883	39.5	380	340	42818
30"	N/A	24-Ø35	6.43	914.4	4-1.25-7	565	660	18	110	165	4-Ø40	984	500	417	965	43	410	370	63513
32"	N/A	24-Ø41	6.43	977.9	4-1.5-6	596	666	20	110	190	4-Ø40	1060	500	417	971	43	490	450	33086
34"	N/A	28-Ø41	5.625	1028.7	4-1.5-6	633	720	20	110	200	4-Ø40	1111	500	450	1032	45	585	530	52300
36"	N/A	28-Ø41	5.625	1085.9	4-1.5-6	656	720	20	110	203	4-Ø42	1168	500	450	1032	46.5	665	610	75688
38"	N/A	28-Ø41	5.625	1149.4	4-1.5-6	675	708	22	110	200	4-Ø44	1238	600	450	1070	50	745	690	91500
40"	2-Ø40	32-Ø41	5	1200.1	4-1.5-6	720	800	22	130	216	4-Ø45	1289	500	470	1109	50	830	760	103584
42"	N/A	32-Ø41	5	1257.3	4-1.5-6	772	850	22	130	251	4-Ø47	1346	500	470	1159	53.5	1070	1000	101638
48"	2-Ø46	40-Ø41	4.1	1422.4	4-1.5-6	864	942	28	130	254	N/A	1511	600	491	1327	57	1300	1160	133210
56"	2-Ø48	44-Ø47.8	3.75	1651	4-1.75-5	1014	1000	40	180	279	N/A	1746	600	491	1385	46	1676	1550	152700

PRESSURE RATING: 26" - 56" ANSI CLASS 150

TEMPERATURE RATING: -20°C to 120°C

FACE TO FACE DIMENSIONS: BS EN 558: 2011 Series 20

END CONNECTIONS: ASME B16.47A

ACTUATOR MOUNTING FLANGES: ISO 5211: 2001

OPERATORS: Gearbox - FA700 (Disc SS 316) / FA701 (Disc SS 304)

BARESHAF VALVE OPTIONS: FA700B

Valid as of 290719

Every effort has been made to ensure that the information contained in this publication is accurate at the time of publishing. Crane Ltd assumes no responsibility or liability for typographical errors or omissions or for any misinterpretation of the information within the publication and reserves the right to change without notice.

FA725G

FA725

Large Diameter Butterfly Valve

ANSI 150

Features & Benefits

- Manufactured to BS EN 593: 2009
- Complies with Pressure Equipment Directive 2014/68/EU
- Suitable for Gearbox or Actuator operation
- Rugged construction: ductile Iron Body for all sizes
- Stainless Steel disc as standard
- Epoxy paint coated as standard
- Low operating torques
- Double regulating feature on gearboxes



Materials

NO.	PART	MATERIAL	SPECIFICATION
1	Key	Carbon Steel	ASTM A29 1045
2	Screw	Carbon Steel	ASTM A194 Gr.2H
3	Short Bushing	-	PTFE
4	O' Ring	-	NBR
5	Upper Shaft	Stainless Steel	ASTM A276 420
6	Body	Ductile Iron	EN-GJS-400-15
7	Long Bushing	-	PTFE
8	Seat + Backing Ring	-	EPDM + Aluminium
9	Disc	Stainless Steel	ASTM A351 CF8M
10	Pin	Stainless Steel	ASTM A276 431
11	Lower Shaft	Stainless Steel	ASTM A276 420
12	Bearing	High Carbon Steel	ASTM A295 52100
13	Lower adjusting shim	Carbon Steel	ASTM A36
14	Screw	Carbon Steel	ASTM A194 Gr. 2H
15	Lower Gland	Carbon Steel	EN-GJS-400-15
16	Gearbox	Cast Iron	-

Dimensional Drawing

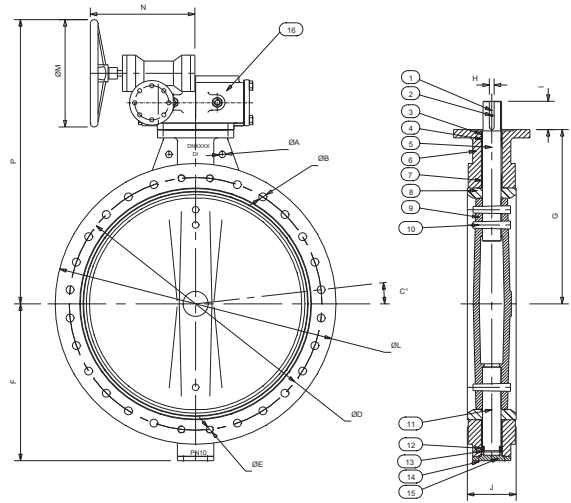

Dimensions & Weights

SIZE (inch)	A (mm)	B (mm)	C (mm)	D (mm)	E (mm)	F (mm)	G (mm)	H (mm)	I (mm)	J (mm)	K (mm)	L (mm)	M (mm)	N (mm)	P (mm)	FLANGE THICKNESS	WEIGHT (kg)		FLOW (kv)
																	Gearbox	Bareshaft	
26"	N/A	20-Ø35	7.5	806.5	4-1.25-7	510	565	14	110	165	N/A	870	400	301	868	39.5	490	410	37300
28"	N/A	24-Ø35	6.43	863.6	4-1.25-7	537	629	18	110	165	4-Ø40	927	400	301	957	39.5	548	468	42818
30"	N/A	24-Ø35	6.43	914.4	4-1.25-7	565	660	20	110	165	4-Ø40	984	400	355	1017	43	647	550	63513
32"	N/A	24-Ø41	6.43	977.9	4-1.5-6	596	666	20	110	190	4-Ø40	1060	400	355	1023	43	725	628	33086
34"	N/A	28-Ø41	5.625	1028.7	4-1.5-6	633	720	20	110	200	4-Ø40	1111	400	355	1077	45	852	755	52300
36"	N/A	28-Ø41	5.625	1085.9	4-1.5-6	656	720	20	110	203	4-Ø42	1168	400	355	1077	46.5	972	875	75688

Kv Values

SIZE (inch)	DISC POSITION (°)								
	10	20	30	40	50	60	70	80	90
26"	20	1050	220	4850	8600	14300	22600	33900	37300
28"	31	1568	3148	5740	8650	12931	19695	30187	42818
30"	32	1799	3811	8257	14714	24347	38531	57798	63513
32"	39	2065	4144	7557	11927	17830	27157	41621	33086
34"	150	2300	5000	9200	14500	22800	36100	55000	52300
36"	225	2638	5821	11020	17490	28113	45413	68854	75688

PRESSURE RATING: 26" - 36" ANSI CLASS 150

TEMPERATURE RATING: -20°C to 120°C

FACE TO FACE DIMENSIONS: BS EN 558: 2011 Series 20

END CONNECTIONS: ASME B16.47A

ACTUATOR MOUNTING FLANGES: ISO 5211: 2001

OPERATORS: Gearbox

Valid as of 290719

Every effort has been made to ensure that the information contained in this publication is accurate at the time of publishing. Crane Ltd assumes no responsibility or liability for typographical errors or omissions or for any misinterpretation of the information within the publication and reserves the right to change without notice.

FM725G

FM725

Large Diameter Butterfly Valve

PN16



GENERAL VALVES

Features & Benefits

- Manufactured to BS EN 593: 2009
- Complies with Pressure Equipment Directive 2014/68/EU
- Suitable for Gearbox or Actuator operation
- Rugged construction: Ductile Iron Body for all sizes
- Stainless Steel disc as standard
- Epoxy paint coated as standard
- Low operating torques
- Double regulating features on gearboxes

Materials

NO.	PART	MATERIAL	SPECIFICATION
1	Key	Carbon Steel	ASTM A29 1045
2	Screw	Carbon Steel	ASTM A194 Gr.2H
3	Short Bushing	-	PTFE
4	O' Ring	-	NBR
5	Upper Shaft	Stainless Steel	ASTM A276 420
6	Body	Ductile Iron	EN-GJS-400-15
7	Long Bushing	-	PTFE
8	Seat + Backing Ring	-	EPDM + Aluminium
9	Disc	Stainless Steel	ASTM A351 CF8M
10	Pin	Stainless Steel	ASTM A276 431
11	Lower Shaft	Stainless Steel	ASTM A276 420
12	Bearing	High Carbon Steel	ASTM A295 52100
13	Lower adjusting shim	Carbon Steel	ASTM A36
14	Screw	Carbon Steel	ASTM A194 Gr. 2H
15	Lower Gland	Carbon Steel	EN-GJS-400-15
16	Gearbox	Cast Iron	-

Dimensional Drawing

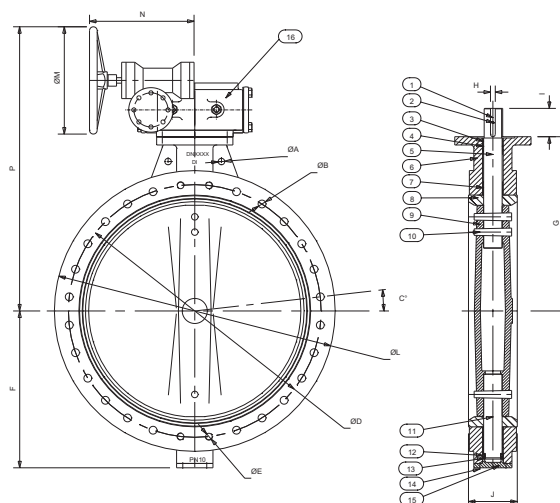

Dimensions & Weights

SIZE (DN)	A (mm)	B (mm)	C (mm)	D (mm)	E (mm)	F (mm)	G (mm)	H (mm)	I (mm)	J (mm)	K (mm)	L (mm)	M (mm)	N (mm)	P (mm)	FLANGE THICKNESS	WEIGHT (kg)		FLOW (kv)
																	Gearbox	Bareshaft	
DN700	N/A	20-Ø37	7.5	840	4-M33	537	629	18	110	165	4-Ø40	910	400	301	957	39.5	548	468	42818
DN800	N/A	20-Ø41	7.5	950	4-M36	596	666	20	110	190	4-Ø40	1025	400	355	1023	43	725	628	33086
DN900	N/A	24-Ø41	6.43	1050	4-M36	656	720	20	110	203	4-Ø42	1125	400	355	1077	46.5	972	875	75688

Kv Values

SIZE (mm)	DISC POSITION (°)								
	10	20	30	40	50	60	70	80	90
700	31	1568	3148	5740	8650	12931	19695	30187	42818
800	39	2065	4144	7557	11927	17830	27157	41621	33086
900	225	2638	5821	11020	17490	28113	45413	68854	75688

PRESSURE RATING: DN700 - DN900 PN16

TEMPERATURE RATING: -20°C to 120°C

FACE TO FACE DIMENSIONS: BS EN 558: 2011 Series 20

END CONNECTIONS: Flanges to BS EN 1092 PN16

ACTUATOR MOUNTING FLANGES: ISO 5211: 2001

OPERATORS: Gearbox

Valid as of 230220

Every effort has been made to ensure that the information contained in this publication is accurate at the time of publishing. Crane Ltd assumes no responsibility or liability for typographical errors or omissions or for any misinterpretation of the information within the publication and reserves the right to change without notice.



Export Butterfly Valves

F648



These valves are designed for export only and are not suitable for use within the EU or UK.

Features & Benefits

GENERAL VALVES

Figure Number	BODY			DISC		SHAFT	LINER / BODY SEAL				BODY STYLE		OPERATOR		RATING							
	Size Range	Ductile Iron	Steel	Aluminium Bronze	Ductile Iron	Stainless Steel	Stainless Steel	EPDM	Nitrile	EPDM WRAS Approved	PTFE	Semi Lugged	Fully Lugged	Lever	Gearbox	PN10	PN16	PN25	PN40	ANSI Class 125	ANSI Class 150	
F676L	50 - 200mm	✓		✓			✓	✓			✓		✓			✓		✓				
F676G	50 - 600mm	✓		✓			✓	✓			✓		✓			✓		✓				
F671L	50 - 200mm	✓		✓			✓		✓		✓		✓			✓		✓				
F671G	50 - 600mm	✓		✓			✓		✓		✓		✓			✓		✓				
F678L	50 - 200mm	✓		✓			✓	✓				✓	✓			✓						
F678G	50 - 600mm	✓		✓			✓	✓				✓	✓			✓						
F674L	50 - 200mm	✓		✓			✓		✓			✓	✓			✓						
F674G	50 - 600mm	✓		✓			✓		✓			✓	✓			✓						
FA678L	2 - 8"	✓		✓			✓	✓				✓	✓					✓				
FA678G	2 - 24"	✓		✓			✓	✓				✓	✓					✓	✓			
FA674L	2 - 8"	✓		✓			✓		✓			✓	✓					✓	✓			
FA674G	2 - 24"	✓		✓			✓		✓			✓	✓					✓	✓			
F646L	50 - 200mm	✓			✓		✓	✓			✓		✓			✓		✓				
F646G	150 - 600mm	✓			✓		✓	✓			✓		✓			✓		✓				
F641L	50 - 200mm	✓			✓		✓		✓		✓		✓			✓		✓				✓
F641G	150 - 600mm	✓			✓		✓		✓		✓		✓			✓		✓				✓
F648L	50 - 200mm	✓			✓		✓	✓				✓	✓			✓						
F648G	150 - 600mm	✓			✓		✓	✓				✓	✓			✓						
F644L	50 - 200mm	✓			✓		✓		✓			✓	✓			✓						
F644G	150 - 600mm	✓			✓		✓		✓			✓	✓			✓						✓
FA648L	2 - 8"	✓			✓		✓	✓				✓	✓					✓				
FA648G	6 - 24"	✓			✓		✓	✓				✓	✓					✓	✓			
FA644L	2 - 8"	✓			✓		✓		✓			✓	✓					✓	✓			
FA644G	6 - 24"	✓			✓		✓		✓			✓	✓					✓	✓			
F656L	50 - 200mm	✓				✓	✓	✓			✓		✓			✓		✓				
F656G	150 - 600mm	✓				✓	✓	✓			✓		✓			✓		✓				
F651L	50 - 200mm	✓				✓	✓		✓		✓		✓			✓		✓				
F651G	150 - 600mm	✓				✓	✓		✓		✓		✓			✓		✓				
F658L	50 - 200mm	✓				✓	✓	✓				✓	✓			✓						
F658G	150 - 600mm	✓				✓	✓	✓				✓	✓			✓						
F654L	50 - 200mm	✓				✓	✓		✓			✓	✓			✓						
F654G	150 - 600mm	✓				✓	✓		✓			✓	✓			✓						
FA658L	2 - 8"	✓				✓	✓	✓				✓	✓					✓				
FA658G	6 - 24"	✓				✓	✓	✓				✓	✓					✓	✓			
FA654L	2 - 8"	✓				✓	✓		✓			✓	✓					✓	✓			
FA654G	6 - 24"	✓				✓	✓		✓			✓	✓					✓	✓			

† WRAS approved product

Valid as of 03/02/20



F646L / F641L / F656L / F651L / F676L / F671L

Semi-Lugged Wafer Pattern Lever Operated Butterfly Valves

PN16 / ANSI 125

Features & Benefits

- Universal Pattern - Valves are suitable for use with flanges conforming to BS EN 1092-2 PN16 or ANSI B16.1 Class 125
- Valve to BS EN593
- Ductile Iron, Stainless Steel, Aluminium Bronze Disc Options
- EPDM and Nitrile Seat Liner Options
- 420 Stainless Steel Shafts for superior strength

Valve Selection

	EPDM LINER	NITRILE LINER
DUCTILE IRON DISC	F646L	F641L
STAINLESS STEEL DISC	F656L	F651L
ALUMINIUM BRONZE DISC	F676L	F671L

Materials

PART	MATERIAL
Body	Ductile Iron (EN-GJS-400-15)
Disc (F646L & F641L) (DN50-200)	Ductile Iron (EN-GJS-400-15) Epoxy coated
Disc (F656L & F651L) (DN50-200)	Stainless Steel 304 (ASTM A351 CF8)
Disc (F676G & F671G) (DN50-200)	Aluminium Bronze (ASTM B148 C95400)
Liner (F646L, F656L & F676L)	EPDM
Liner (F641L, F651L & F671L)	Nitrile Rubber
Shaft	Stainless Steel 420 (ASTM A276 420)
Taper Pin	Stainless Steel 431 (ASTM A276 431)
O-Ring	Nitrile Rubber
Bushing	PTFE
Lever & Screw	Malleable Iron ASTM Gr.32510
Stop Plate	Mild Steel (GB700 Q235) Chromium Plated



F646L

GENERAL VALVES

Dimensional Drawing

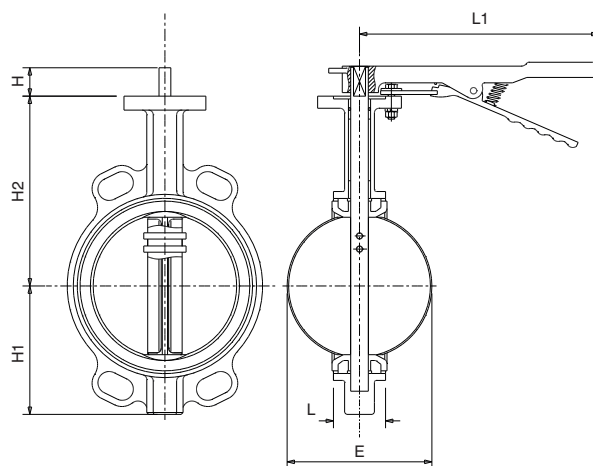

Dimensions & Weights

SIZE (mm)	WEIGHT (kg)	H2	H1	L	H	L1	ØE	Kv
50	2.6	141	61	43	32	216	52.9	133
65	3.0	153	72	46	32	216	64.7	227
80	3.4	161	87	46	32	216	79.1	349
100	4.9	179	106	52	32	265	104.4	694
125	6.3	193	123	56	32	265	123.3	1181
150	7.3	204	137	56	32	265	155.6	1825
200	12.2	247	174	60	45	374	202.5	2503

Pressure/Temperature Ratings

	F646L/F656L/F676L	F641L/F651L/F671L
TEMPERATURE (°C)	-10 to 120	-10 to 82
PRESSURE (BAR)	16	16

PRESSURE RATING: PN16 & ANSI Class 125

END CONNECTION: Semi-Lugged

OPERATOR: Trigger Lever

OTHER: Bare shaft options available (Fig No. F646B / F641B / F656B / F651B / F676B / F671B)
Please contact us for bare shaft top works details

SPECIFICATION: End connections compatible with BS EN1092-2 PN16 & ANSI B16.1 Class 125 flanges.

TEST PRESSURES: (Hydrostatic)

SHELL: 24 bar

SEAT: 17.6 bar

Valid as of 140819

Every effort has been made to ensure that the information contained in this publication is accurate at the time of publishing. Crane Ltd assumes no responsibility or liability for typographical errors or omissions or for any misinterpretation of the information within the publication and reserves the right to change without notice.



F646G

F646G / F641G / F656G / F651G / F676G / F671G

Semi-Lugged Wafer Pattern Gearbox Operated Butterfly Valves

PN16 / ANSI 125



GENERAL VALVES

Features & Benefits

- Universal Pattern - Valves are suitable for use with flanges conforming to BS EN 1092-2 PN16 or ANSI B16.1 Class 125
- Valve to BS EN593
- Ductile Iron, Stainless Steel, Aluminium Bronze Disc Options
- EPDM and Nitrile Seat Liner Options
- 420 Stainless Steel Shafts for superior strength

Valve Selection

	EPDM LINER	NITRILE LINER
DUCTILE IRON DISC	F646G	F641G
STAINLESS STEEL DISC	F656G	F651G
ALUMINIUM BRONZE DISC	F676G	F671G

Materials

PART	MATERIAL
Body	Ductile Iron (EN-GJS-400-15)
Disc (F646G & F641G) (DN150-600)	Ductile Iron (EN-GJS-400-15) Epoxy Coated
Disc (F656G & F651G) (DN150-600)	Stainless Steel 304 (ASTM A351 CF8)
Disc (F676G & F671G) (DN50-600)	Aluminium Bronze (ASTM B148 C95400)
Liner (F646G, F656G & F676G)	EPDM
Liner (F641G, F651G & F671G)	Nitrile Rubber
Shaft	Stainless Steel 420 (ASTM A276 420)
Taper Pin	Stainless Steel 431 (ASTM A276 431)
O-Ring	Nitrile Rubber
Bushing	PTFE

Dimensional Drawing

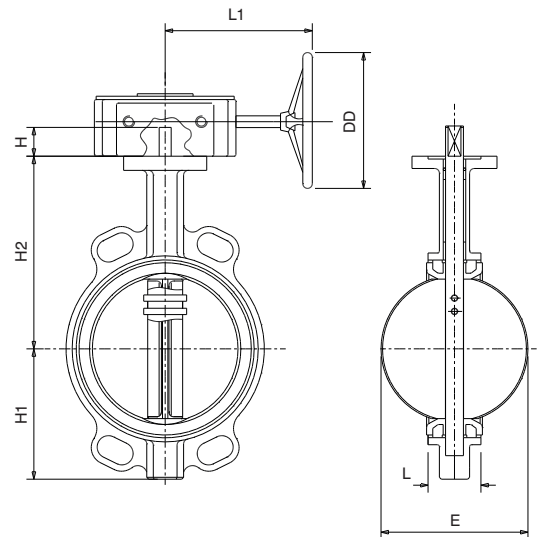

Dimensions & Weights

SIZE (mm)	WEIGHT (kg)		H2	H1	L	H	L1	ØE	DD	Kv
	BARESHAF	GEARBOX								
50	2.1	7.0	141	61	43	32	157	52.9	145	133
65	2.5	7.4	153	72	46	32	157	64.7	145	227
80	2.9	7.8	161	87	46	32	157	79.1	145	349
100	4.2	9.1	179	106	52	32	157	104.4	145	694
125	5.6	10.5	193	123	56	32	157	123.3	145	1181
150	6.6	11.5	204	137	56	32	157	155.6	145	1825
200	11.3	20.1	247	174	60	45	236	202.5	300	2503
250	17.3	26.0	280	209	68	45	236	250.5	300	3876
300	24.7	36.0	324	253	78	45	237	301.6	300	6736
350	37.0	48.0	310	255	78	48	237	333.6	300	8135
400	57.0	82.0	340	317.5	102	64	246	389.5	300	12041
450	75.0	100.0	375	330	114	64	246	440.5	380	14121
500	104.0	134.0	425	367	127	64	254	489.7	285	18449
600	157.0	207.0	505	443	154	82	301	592.7	400	24125

Pressure/Temperature Ratings

	F646G/F656G/F676G	F641G/F651G/F671G
TEMPERATURE (°C)	-10 to 120	-10 to 82
PRESSURE (BAR)	16	16

PRESSURE RATING: PN16 & ANSI Class 125

END CONNECTION: Semi-Lugged

OPERATOR: Gearbox

OTHER: Bare shaft options available

(Fig No. F646B / F641B / F656B / F651B / F676B / F671B)

Please contact us for bare shaft top works details

SPECIFICATION: End connections compatible with BS EN1092-2 PN16 & ANSI B16.1 Class 125 flanges.

TEST PRESSURES: (Hydrostatic)

SHELL: 24 bar

SEAT: 17.6 bar

Valid as of 14/08/19

Every effort has been made to ensure that the information contained in this publication is accurate at the time of publishing. Crane Ltd assumes no responsibility or liability for typographical errors or omissions or for any misinterpretation of the information within the publication and reserves the right to change without notice.



F648L / F644L / F658L / F654L / F678L / F674L

Fully Lugged Lever Operated Butterfly Valves

PN16

F648L



GENERAL VALVES

Features & Benefits

- Valves are suitable for use with flanges conforming to BS EN 1092-2 PN16
- Valve to BS EN593
- Ductile Iron, Stainless Steel, Aluminium Bronze Disc Options
- EPDM and Nitrile Seat Liner Options
- 420 Stainless Steel Shafts for superior strength

Valve Selection

	EPDM LINER	NITRILE LINER
DUCTILE IRON DISC	F648L	F644L
STAINLESS STEEL DISC	F658L	F654L
ALUMINIUM BRONZE DISC	F678L	F674L

Materials

PART	MATERIAL
Body	Ductile Iron (EN-GJS-400-15)
Disc (F648L & F644L) (DN50-200)	Ductile Iron (EN-GJS-400-15) Epoxy coated
Disc (F658L & F654L) (DN50-200)	Stainless Steel 304 (ASTM A351 CF8)
Disc (F678L & F674L) (DN50-200)	Aluminium Bronze (ASTM B148 C95400)
Liner (F648L, F658L & F678L)	EPDM
Liner (F644L, F654L & F674L)	Nitrile Rubber
Shaft	Stainless Steel 420 (ASTM A276 420)
Taper Pin	Stainless Steel 431 (ASTM A276 431)
O-Ring	Nitrile Rubber
Bushing	PTFE
Lever & Screw	Malleable Iron ASTM Gr.32510
Stop Plate	Mild Steel (GB700 Q235) Chromium Plated

Dimensional Drawing

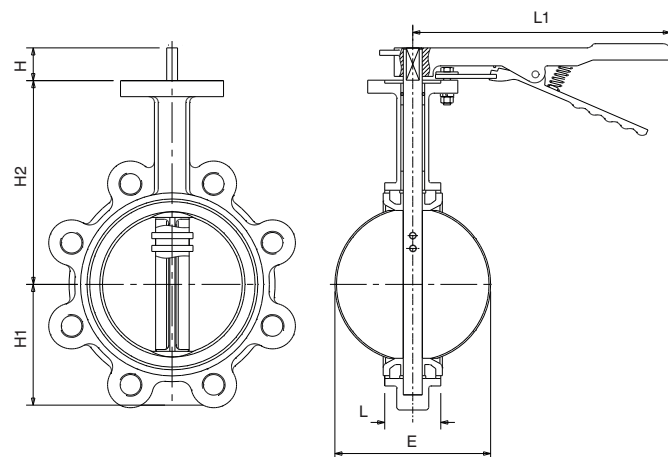

Dimensions & Weights

SIZE (mm)	WEIGHT (kg)	H2	H1	L	H	L1	ØE	Kv
50	3.5	141	61	43	32	216	52.9	133
65	3.9	153	72	46	32	216	64.7	227
80	5.2	161	87	46	32	216	79.1	349
100	7.3	179	106	52	32	265	104.4	694
125	9.8	193	123	56	32	265	123.3	1181
150	10.7	204	137	56	32	265	155.6	1825
200	18.3	247	174	60	45	374	202.5	2503

Pressure/Temperature Ratings

	F648L/F658L/F678L	F644L/F654L/F674L
TEMPERATURE (°C)	-10 to 120	-10 to 82
PRESSURE (BAR)	16	16

PRESSURE RATING: PN16

END CONNECTION: Fully Lugged

OPERATOR: Trigger Lever

OTHER: Bare shaft options available

(Fig No. F648B / F658B / F644B / F654B / F678B / F674B)

Please contact us for bare shaft top works details

SPECIFICATION: End connections compatible with BS EN1092-2 PN16 flanges.

TEST PRESSURES: (Hydrostatic)

SHELL: 24 bar

SEAT: 17.6 bar

Valid as of 14/08/19

Every effort has been made to ensure that the information contained in this publication is accurate at the time of publishing. Crane Ltd assumes no responsibility or liability for typographical errors or omissions or for any misinterpretation of the information within the publication and reserves the right to change without notice.



F648G / F644G / F658G / F654G / F678G / F674G / F678WG

Fully Lugged Gearbox Operated
Butterfly Valves

PN16

F678WG WRAS Approved



F648G



Features & Benefits

- Valves are suitable for use with flanges conforming to BS EN 1092-2 PN16
- Valve to BS EN593
- Ductile Iron, Stainless Steel, Aluminium Bronze Disc Options
- EPDM and Nitrile Seat Liner Options
- 420 Stainless Steel Shafts for superior strength

Materials

PART	MATERIAL
Body	Ductile Iron (EN-GJS-400-15)
Disc (F648G & (F644G) (DN150-600)	Ductile Iron (EN-GJS-400-15) Epoxy Coated
Disc (F658G & F654G) (DN150-600)	Stainless Steel 304 (ASTM A351 CF8)
Disc (F678G & F674G) (DN50-600)	Aluminium Bronze (ASTM B148 C95400)
Liner (F648G, F658G & F678G)	EPDM
Liner (F644G, F654G & F674G)	Nitrile rubber
Liner (F678WG)	EPDM (WRAS Approved) Temp. -10 to 100°C (80°C WRAS)
Shaft	Stainless Steel 420 (ASTM A276 420)
Taper Pin	Stainless Steel 431 (ASTM A276 431)
O-Ring	Nitrile rubber
Bushing	PTFE

Valve Selection

	EPDM LINER	NITRILE LINER
DUCTILE IRON DISC	F648G	F644G
STAINLESS STEEL DISC	F658G	F654G
ALUMINIUM BRONZE DISC	F678G	F674G
WRAS ALUMINIUM BRONZE DISC, EPDM LINER	F678WG	-

Dimensional Drawing

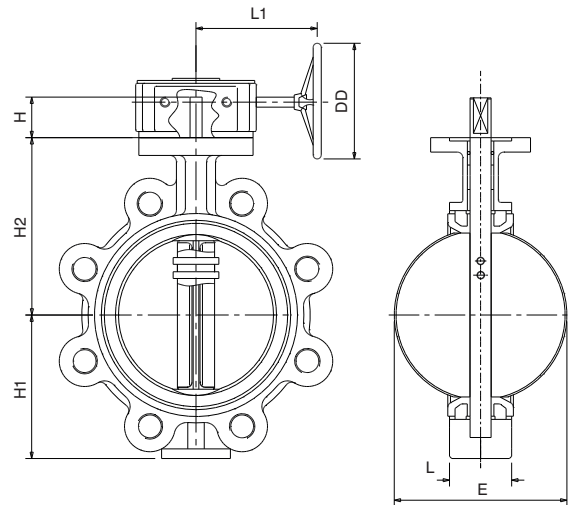

Dimensions & Weights

SIZE (mm)	WEIGHT (kg)		H2	H1	L	H	L1	ØE	DD	Kv
	BARESHAF	GEARBOX								
50	3.0	7.9	141	61	43	32	157	52.9	145	133
65	3.4	8.3	153	72	46	32	157	64.7	145	227
80	4.7	9.6	161	87	46	32	157	79.1	145	349
100	6.6	11.5	179	106	52	32	157	104.4	145	694
125	9.1	14.0	193	123	56	32	157	123.3	145	1181
150	10.0	14.9	204	137	56	32	157	155.6	145	1825
200	17.4	26.2	247	174	60	45	236	202.5	300	2503
250	25.0	34.0	280	209	68	45	236	250.5	300	3876
300	34.0	46.0	324	253	78	45	237	301.6	300	6736
350	52.0	63.0	310	260	78	48	237	333.6	300	8135
400	81.0	106.0	340	317.5	102	64	246	389.5	300	12041
450	106.0	131.0	375	330	114	64	246	440.5	380	14121
500	140.0	170.0	425	367	127	64	254	489.7	285	18449
600	220.0	270.0	505	443	154	82	301	592.7	400	24125

Pressure/Temperature Ratings

	F648G / F658G / F678G	F644G / F654G / F674G	F678WG
TEMPERATURE (°C)	-10 to 120	-10 to 82	-10 to 100 (WRAS to 80)
PRESSURE (BAR)	16	16	16

PRESSURE RATING: PN16

END CONNECTION: Fully Lugged

OPERATOR: Gearbox

OTHER: Bare shaft options available

(Fig No. F648B / F644B / F658B / F654B / F678B / F674B)

Please contact us for bare shaft top works details

SPECIFICATION: End connections compatible with BS EN1092-2 PN16 flanges.

TEST PRESSURES: (Hydrostatic)

SHELL: 24 bar

SEAT: 17.6 bar

Valid as of 111219

Every effort has been made to ensure that the information contained in this publication is accurate at the time of publishing. Crane Ltd assumes no responsibility or liability for typographical errors or omissions or for any misinterpretation of the information within the publication and reserves the right to change without notice.



FA648L / FA644L / FA658L / FA654L / FA678L / FA674L / FA678WL

Fully Lugged Lever Operated
Butterfly Valves

ANSI 125
FA678WL WRAS Approved



GENERAL VALVES

Features & Benefits

- Valves are suitable for use with flanges conforming to ANSI B16.1 Class 125
- Valve generally conforms to MSS SP 67
- Ductile Iron, Stainless Steel, Aluminium Bronze Disc Options
- EPDM and Nitrile Seat Liner Options
- 420 Stainless Steel Shafts for superior strength

Materials

PART	MATERIAL
Body	Ductile Iron (EN-GJS-400-15)
Disc (FA648L & FA644L) (2"-8")	Ductile Iron (EN-GJS-400-15) Epoxy Coated
Disc (FA658L & FA654L) (2"-8")	Stainless Steel 304 (ASTM A351 CF8)
Disc (FA678L & FA674L) (2"-8")	Aluminium Bronze (ASTM B148 C95400)
Liner (FA648L, FA658L & FA678L)	EPDM
Liner (FA644L, FA654L & FA674L)	Nitrile rubber
Liner (FA678WL)	EPDM (WRAS Approved) Temp. -10 to 100°C (80°C WRAS)
Shaft	Stainless Steel 420 (ASTM A276 420)
Taper Pin	Stainless Steel 431 (ASTM A276 431)
O-Ring	Nitrile rubber
Bushing	PTFE
Lever & Screw	Malleable Iron ASTM Gr.32510
Stop Plate	Mild Steel (GB700 Q235) Chromium Plated

Valve Selection

	EPDM LINER	NITRILE LINER
DUCTILE IRON DISC	FA648L	FA644L
STAINLESS STEEL DISC	FA658L	FA654L
ALUMINIUM BRONZE DISC	FA678L	FA674L
WRAS ALUMINIUM BRONZE DISC, EPDM LINER	FA678WL	-

Dimensional Drawing

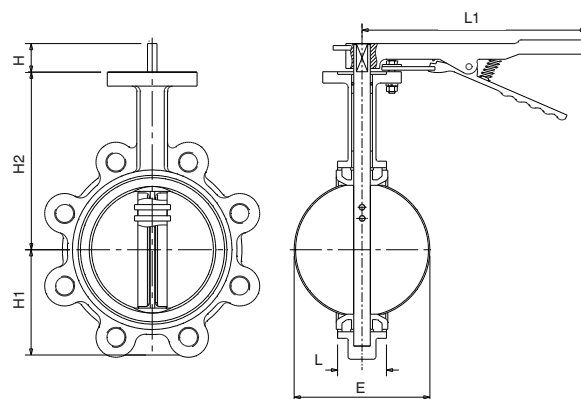

Dimensions & Weights

SIZE (inch)	WEIGHT (kg)	H2	H1	L	H	L1	ØE	Kv
2	3.5	141	61	43	32	216	52.9	133
2 1/2	3.9	153	72	46	32	216	64.7	227
3	5.2	161	87	46	32	216	79.1	349
4	7.3	179	106	52	32	265	104.4	694
5	9.8	193	123	56	32	265	123.3	1181
6	10.7	204	137	56	32	265	155.6	1825
8	18.3	247	174	60	45	374	202.5	2503

Pressure/Temperature Ratings

	FA648L / FA658L / FA678L	FA644L / FA654L / FA674L	FA678WL
TEMPERATURE (°C)	-10 to 120	-10 to 82	-10 to 100 (WRAS to 80)
PRESSURE (BAR)	16	16	16

PRESSURE RATING: ANSI 125

END CONNECTION: Fully Lugged

OPERATOR: Trigger Lever

OTHER: Bare shaft options available

(Fig No. FA648B / FA658B / FA644B / FA654B / FA678B / FA674B)

Please contact us for bare shaft top works details

SPECIFICATION: End connections compatible with ANSI B16.1 Class 125 flanges.

TEST PRESSURES: (Hydrostatic)

SHELL: 24 bar

SEAT: 17.6 bar

Valid as of 111219

Every effort has been made to ensure that the information contained in this publication is accurate at the time of publishing. Crane Ltd assumes no responsibility or liability for typographical errors or omissions or for any misinterpretation of the information within the publication and reserves the right to change without notice.



FA648G / FA644G / FA658G / FA654G / FA678G / FA674G

Fully Lugged Gearbox Operated Butterfly Valves

ANSI 125

FA648G



Features & Benefits

- Valves are suitable for use with flanges conforming to ANSI B16.1 Class 125
- Valve generally conforms to MSS SP 67
- Ductile Iron, Stainless Steel, Aluminium Bronze Disc Options
- EPDM and Nitrile Seat Liner Options
- 420 Stainless Steel Shafts for superior strength

Valve Selection

	EPDM LINER	NITRILE LINER
DUCTILE IRON DISC	FA648G	FA644G
STAINLESS STEEL DISC	FA658G	FA654G
ALUMINIUM BRONZE DISC	FA678G	FA674G

Materials

PART	MATERIAL
Body	Ductile Iron (EN-GJS-400-15)
Disc (FA648G & FA644G) (6"-24")	Ductile Iron (EN-GJS-400-15) Epoxy Coated
Disc (FA658G & FA654G) (6"-24")	Stainless Steel 304 (ASTM A351 CF8)
Disc (FA678G & FA674G) (2"-4")	Aluminium Bronze (ASTM B148 C95400)
Liner (FA648G, FA658G & FA678G)	EPDM
Liner (FA644G, FA654G & FA674G)	Nitrile rubber
Shaft	Stainless Steel 420 (ASTM A276 420)
Taper Pin	Stainless Steel 431 (ASTM A276 431)
O-Ring	Nitrile rubber
Bushing	PTFE

Dimensional Drawing

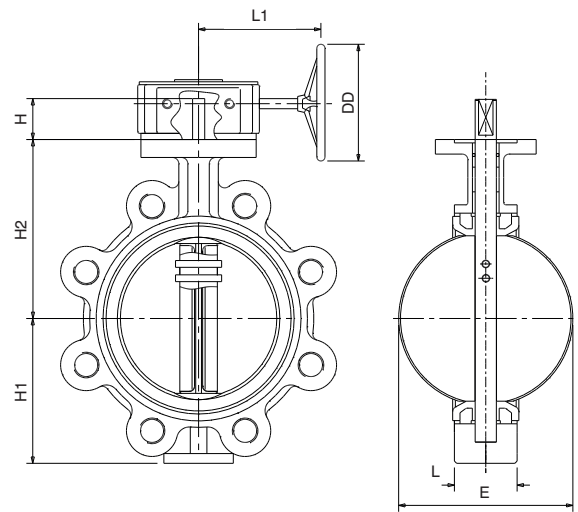

Dimensions & Weights

SIZE (inch)	WEIGHT (kg)		H2	H1	L	H	L1	ØE	DD	Kv
	BARESHAF	GEARBOX								
2	3.0	7.9	141	61	43	32	157	52.9	145	133
2.5	3.4	8.3	153	72	46	32	157	64.7	145	227
3	4.7	9.6	161	87	46	32	157	79.1	145	349
4	6.6	11.5	179	106	52	32	157	104.4	145	694
5	9.1	14.0	193	123	56	32	157	123.3	145	1181
6	10.0	14.9	204	137	56	32	157	155.6	145	1825
8	17.4	26.2	247	174	60	45	236	202.5	300	2503
10	25.0	34.0	280	209	68	45	236	250.5	300	3876
12	34.0	46.0	324	253	78	45	237	301.6	300	6736
14	52.0	63.0	310	260	78	48	237	333.6	300	8135
16	81.0	106.0	340	317.5	102	64	246	389.5	300	12041
18	106.0	131.0	375	330	114	64	246	440.5	380	14121
20	140.0	170.0	425	367	127	64	254	489.7	285	18449
24	220.0	270.0	505	443	154	82	301	592.7	400	24125

Pressure/Temperature Ratings

	FA648G/FA658G/FA678G	FA644G/FA654G/FA674G
TEMPERATURE (°C)	-10 to 120	-10 to 82
PRESSURE (BAR)	15.3	15.3

PRESSURE RATING: ANSI 125

END CONNECTION: Fully Lugged

OPERATOR: Gearbox

OTHER: Bare shaft options available (Fig No. FA648B / FA658B / FA644B / FA654B / FA678B / FA674B)

Please contact us for bare shaft top works details

SPECIFICATION: End connections compatible with ANSI B16.1 Class 125 flanges.

TEST PRESSURES: (Hydrostatic)

SHELL: 24 bar

SEAT: 17.6 bar

Valid as of 140819

Every effort has been made to ensure that the information contained in this publication is accurate at the time of publishing. Crane Ltd assumes no responsibility or liability for typographical errors or omissions or for any misinterpretation of the information within the publication and reserves the right to change without notice.

**PROJECT**

Kempinski Hotel Marsa Malaz, Doha

Marsa Malaz Kempinski, the first ultra-luxury hotel to open on Doha's iconic Pearl Island, comprises 281 rooms, including 73 suites, two Presidential Suites and two Royal Suites.

The complex includes six restaurants, lounge café, bar, rooftop nightclub with large open-air terraces, as well as a pool restaurant, spa café and a health club with an indoor pool. The hotel also features a Grand Ballroom and seven meeting rooms. The island has a private beach and outdoor swimming pools, water sports facilities, yachts jetty, tennis courts and plush gardens and patios.

LOCATION:

Doha, Qatar

CLIENT:

Kempinski

CONSULTANT:

Arab Engineering Bureau

CONTRACTOR:

CDC Construction Development Company

CHANNEL PARTNER:

AlRiyadh Trading & Contracting

SPECIFICATION:

Crane FS Balancing Valves and a wide selection of General Valves and Strainers.

PROJECT

Piccadilly Gate

Previously The Rail House, Piccadilly Gate comprises 10 floors and 13,000 sq m of contemporary office space in an area seen as the focus for the city's growing professional, financial and public sector occupiers. The fully air-conditioned space is underwent a £8 million refit making it a premier commercial address in the city of Manchester.

Fitted with fan coils and chilled beams, Crane Fluid System's Dominator has been installed throughout the build. The Dominator is a compact prefabricated unit which combines essential control components and connecting pipework which is ready for a simple and fast on-site connection to the terminal units. The Dominator allows the Rail House to control and measure flow around the building and is ideal for flushing and isolation.

LOCATION:

Manchester

CLIENT:

Manchester County Council

CONSULTING**ENGINEER:**

Shepherd Engineering Services Ltd

ARCHITECTURAL**DESIGN/MAIN****CONTRACTOR:**

OCON Construction

DISTRIBUTOR:

BSS (Salford) Ltd

SPECIFICATION:

Dominator

**PROJECT**

Lyric Theatre

Crane Fluid Systems provided a range of General Valves to the extension of The Lyric Hammersmith Theatre in London.

The new £16.5 million building is changing the landscape of Hammersmith with a new drama, dance, film and TV recording studios; a 60-seat cinema; and a new bar and café. As well as this large extension to the west of the theatre, the existing building will undergo its first major facelift in 30 years.

The Lyric is aiming to become one of the most sustainable cultural buildings in London with a green roof, almost 100 per cent LED lighting and reclaimed furniture.

LOCATION:

Hammersmith, London

CLIENT:

Lyric Theatre

CONTRACTOR:

Mace Plus

DISTRIBUTOR:

Pipe - Greenford

SPECIFICATION:

General valves

Check Valves

Check valves permit flow in one direction only, and close automatically if flow reverses. They are entirely automatic in action, depending upon pressure and velocity of flow within the line to perform their functions of opening and closing. Most Crane Fluid System swing check valves can be installed in horizontal or vertical upward flow piping. Lift check valves must be used in horizontal lines only.

CFS offers four basic types of bronze check valves, namely:

- Horizontal lift check
- Vertical lift check
- Swing check
- Double check

Swing check valves, having 6 diameters of straight lengths of pipe upstream and 3 diameters downstream, are suitable for velocities up to 3 metres/second. If the valve is situated such that turbulent flow enters the valve, the velocity should not exceed 2 metres/second.

Horizontal lift check valves are primarily used for air, gas and steam services whilst swing check valves are most suitable for water and other liquids.

For air, gas and low pressure applications, especially where bubble tight closure is required, a valve with rubber faced disc is necessary.

Compressed air service requires a horizontal lift check valve with a nitrile rubber facing on the disc and fitted with a recoil spring. The valve should always be installed as far away from the compressor as possible.

When selecting valves, reference to codes of practice and other mandatory specifications should be made which may preclude certain types for specific applications.

Double check valves are designed to prevent contamination of water caused by back syphonage, back flow and cross connection in supplies such as those to hose taps, cisterns, stand pipes, showers and basins.

Valves, where designated, are WRAS Approved Products and listed in the Water Fittings and Materials Directory

D142

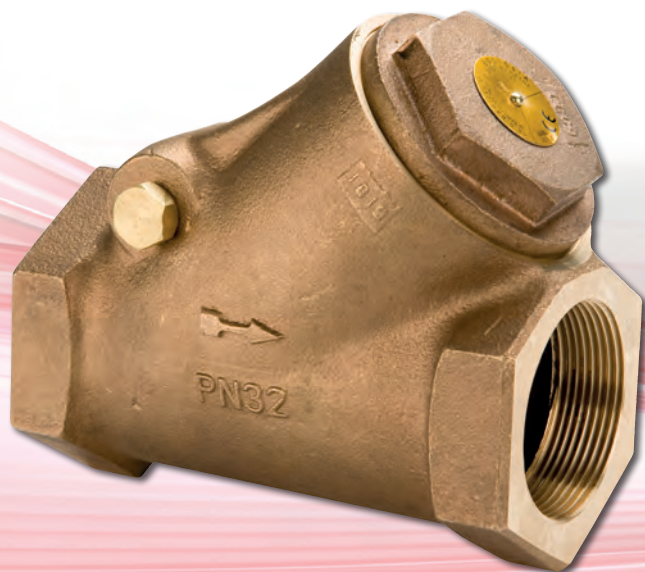

Fig. No.	PN / ANSI Rating	End Connections	Size Range	Disc / Cartridge Material	Body Material	Lift Type
D104	20	Threaded	1/2 - 2"	"Brass (1/2 & 3/4") Bronze (1 - 2")"	Bronze	Verticle
D116	32	Threaded	1/4 - 2"	PTFE	Bronze	Verticle
D138	25	Threaded	3/8 - 3"	"Brass (1/4 - 1") Bronze (1 1/4 - 3")"	Bronze	Swing
D140	25	Threaded	1/2 - 2"	Nitrile	Bronze	Swing
D140W†	25	Threaded	3/4 - 2"	Nitrile	Bronze	Swing
D142	32	Threaded	1/4 - 3"	"Brass (1/4 & 3/4") Bronze (1 - 3")"	Bronze	Swing
D120W†	10*	Threaded	1/2 - 2"	Acetal	DZR Brass	In Line Single Check
D120CW†	10*	Compression	15 - 28mm	Acetal	DZR Brass Nickle Plated	In Line Single Check
D220W†	10*	Threaded	1/2 - 2"	Acetal	DZR Brass	In Line Double Check
D220CW†	10*	Compression	15 - 28mm	Acetal	DZR Brass Nickle Plated	In Line Double Check
D130W†	16	Flanged	50 -300mm	Cast Iron + EPDM	Cast Iron	In Line Single Check
D230W	16	Flanged	50 -300mm	Cast Iron + EPDM	Cast Iron	In Line Double Check
FM469	PN16	Flanged	50 - 300mm	Cast Iron	Cast Iron	Swing
FM492	PN16	Flanged	50 - 300mm	Cast Iron	Cast Iron	Swing
F491	Class 100	Flanged	2 - 8"	Cast Iron	Cast Iron	Swing
F493	Class 125	Flanged	2 - 12"	Cast Iron	Cast Iron	Swing
FM463	16	Wafer	50 - 600mm	Stainless Steel	"Cast Iron (50-150mm) Ductile Iron (200 - 600mm)"	In Line Double Door
FA463	Class 125	Wafer	2 - 24"	Stainless Steel	"Cast Iron (50-150mm) Ductile Iron (200 - 600mm)"	In Line Double Door
FM466	25	Wafer	50 - 600mm	Stainless Steel	Ductile Iron	In Line Double Door
147XU	Class 150	Flanged	2 - 24"	Steel	Cast Steel	Swing
159XU	Class 300	Flanged	2 - 24"	Steel	Cast Steel	Swing

† WRAS approved product

* Shell pressure rating is 16 Bar. Max inlet pressure is 10 Bar

D104

Bronze lift Check Valve

D104

PN20



Features & Benefits

- Check valves permit flow in one direction only and close automatically if flow reverses
- Entirely automatic in action, depending upon pressure and velocity of flow within the line to perform their functions of opening and closing
- Lift Check Valves should only be used in horizontal pipe runs
- The Crane D104 check valve is of the lift check variety

Materials

NO.	PART	MATERIAL	SIZES
1	Body	Bronze BS EN 1982 CC491K	All
2	Cap	Brass BS EN 12164 CW614N	1/2 only
2	Cap	Bronze BS EN 1982 CC491K	3/4 - 2
3	Disc	Bronze BS EN 1982 CC491K	1 - 2
3	Disc	Brass BS EN 12164 CW614N	1/2 & 3/4
4	ID Plate	Aluminium	All
5	Drive Pin	Steel - Electro Brassed	All

Dimensions & Weights

SIZE (inch)	WEIGHT (kg)	A (mm)	B (mm)
1/2	0.24	55	33
3/4	0.35	63	33
1	0.6	77	39
1 1/4	0.97	91	47
1 1/2	1.26	98	54
2	2.09	118	65

Dimensional Drawing

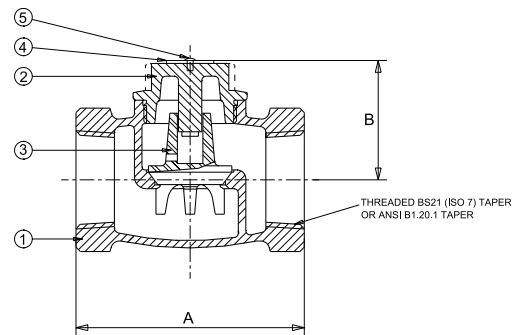

Pressure/Temperature Ratings

TEMPERATURE (°C)	-10 to 100	180
PRESSURE (BAR)	20	9

Intermediate pressure ratings shall be determined by interpolation.

PRESSURE RATING: PN20

TEMPERATURE OPERATING RANGE: -10 to 180°C

UK END CONNECTION: BS 21 Taper

US END CONNECTION: ANSI B1.20.1

OPERATOR: Lift Check Valve

SPECIFICATION: Valves are manufactured in accordance with BS 5154.

Disc is spherical shaped guided in the cap. Body seat is integral.

This valve is not suitable for use on Group 1 gases or unstable fluids, as defined by the Pressure Equipment Directive 2014/68/EU.*

* See page 155 for more information

D116

Bronze Lift Check Valve

D116

PN32



GENERAL VALVES

Features & Benefits

- Lift Check Valves should only be used in horizontal pipe runs
- The Crane D116 check valve is of the lift check variety

Materials

NO.	PART	MATERIAL	SIZES
1	Body	Bronze BS EN 1982 CC491K	All
2	Union Ring Bronze	BS EN 1982 CC491K	1/4 - 2
3	Cap Bronze	BS EN 1982 CC491K	All
4	Cap Studs Steel	BS 970 070M20	2 1/2 & 3
5	Cap Stud Nuts Steel	BS 4190 Gr.4.0	2 1/2 & 3
6	Disc Holder Bronze	BS EN 1982 CC491K	All
7	Disc Retaining Nut Bronze	BS EN 1982 CC491K	1/2 - 3
7	Disc Retaining Nut Brass	BS EN 12164 CW614N	1/4 & 3/8
8	Washer Brass	BS EN 12164 CW614N	1/4 & 3/8
9	Disc	PTFE (25% Glass Filled)	All
10	Gasket	Asbestos Free	2 1/2 & 3
11	ID Plate	Aluminium	All

Dimensions & Weights

SIZE (inch)	WEIGHT (kg)	A (mm)	B (mm)
1/2	0.37	59	37
3/8	0.36	59	37
1/2	0.51	68	43
3/4	0.85	81	49
1	1.32	95	56
1 1/4	1.97	108	65
1 1/2	2.65	121	73
2	4.44	146	87
2 1/2	9	184	94
3	13.6	210	107

Dimensional Drawing

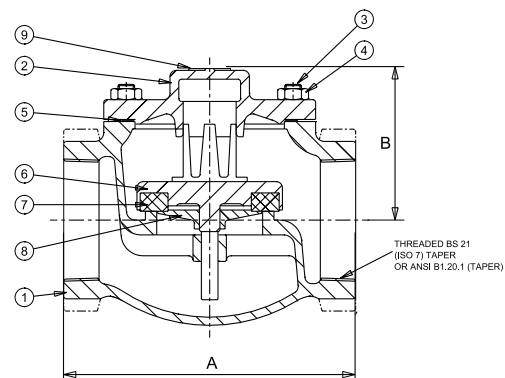
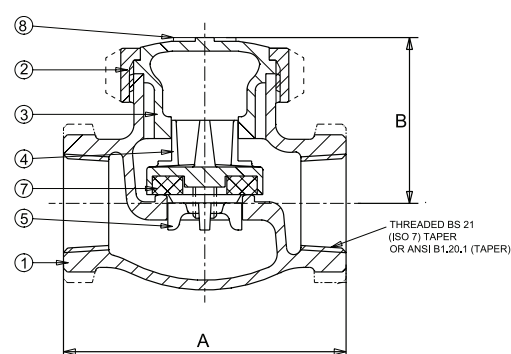

Pressure/Temperature Ratings

TEMPERATURE (°C)	-10 to 100	198
PRESSURE (BAR)	32	14

Intermediate pressure ratings shall be determined by interpolation.

PRESSURE RATING: PN32

TEMPERATURE OPERATING RANGE: -10 to 198°C

UK END CONNECTION: BS 21 Taper

US END CONNECTION: ANSI B1.20.1

OPERATOR: Lift Check Valve

SPECIFICATION: Valves are manufactured in accordance with BS 5154 PN32

for Series B ratings. The design incorporates a disc holder which is guided in the seat bore and the cap. The body seat is integral of the semi-crown type. Sizes 1/4" to 2" have a union cap; sizes 2 1/2" and 3" have a bolted cap.

This check valve is available with a nitrile rubber disc for air, hot and cold water. This valve is not suitable for use on Group 1 gases or unstable fluids, as defined by the Pressure Equipment Directive 2014/68/EU.*

* See page 155 for more information

D138

Bronze Swing Check Valve with Metal Disc



PN25

D116



Features & Benefits

- Check valves permit flow in one direction only and close automatically if flow reverses.
- Entirely automatic in action, depending upon pressure and velocity of flow within the line to perform their functions of opening and closing
- The Crane D138 Bronze check valve is of the swing variety.
- This valve carries the British Standards Institution kitemark

Materials

NO.	MATERIAL	SIZES
Body	Bronze BS EN 1982 CC491K	All
Cap	Bronze BS EN 1982 CC491K	All
Disc	Brass BS EN 12164 CW614N	$\frac{3}{8}$ - 1
Disc	Bronze BS EN 1982 CC491K	1 $\frac{1}{4}$ - 3
Hinge	Bronze BS EN 1982 CC491K	All
Hinge Pin	Stainless Steel	$\frac{3}{8}$ - 2
Hinge Pin	Stainless Steel ASTM A182 Gr.F316	2 $\frac{1}{2}$ & 3
Hinge Nut	Brass BS EN 12164 CW614N	All
ID Plate	Aluminium	All
Drive Pin	Steel - Electro Brassed	All
Hinge Pin Plug	Brass BS EN 12164 CW614N	2 $\frac{1}{2}$ & 3

Dimensional Drawing

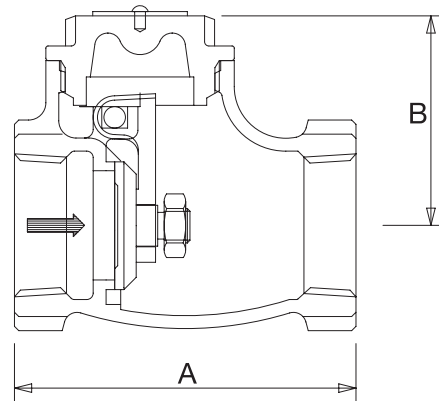

Dimensions & Weights

SIZE (inch)	WEIGHT (kg)	A (mm)	B (mm)
$\frac{3}{8}$	0.19	48	33
$\frac{1}{2}$	0.32	58	38
$\frac{3}{4}$	0.43	66	42
1	0.61	80	49
1 $\frac{1}{4}$	1.01	89	56
1 $\frac{1}{2}$	1.34	95	65
2	2.12	108	76
2 $\frac{1}{2}$	4.08	155	98
3	5.76	190	99

Pressure/Temperature Ratings

TEMPERATURE (°C)	-10 to 100	110	120	186
PRESSURE (BAR)	25.0	23.4	21.8	10.5

Intermediate pressure ratings shall be determined by interpolation.

PRESSURE RATING: PN25

TEMPERATURE OPERATING RANGE: -10 to 186

UK END CONNECTION: Taper threaded to BS EN 10226-2 (ISO 7-1) formerly BS 21

US END CONNECTION: ANSI B1.20.1

(please add suffix AT to denote American Thread)

OPERATOR: Swing Type Check Valve

SPECIFICATION: Metal Disc, Screwed in Cap, BSI Kitemark approved.

Valves are manufactured in accordance with BS5154:1991 PN25 for Series B ratings.

This valve is not suitable for use on Group 1 gases or unstable fluids, as defined by the Pressure Equipment Directive 2014/68/EU.*

* See page 155 for more information

D140

Bronze Swing Check Valve with Resilient Disc



PN25

D116



GENERAL VALVES

Features & Benefits

- Check valves permit flow in one direction only and close automatically if flow reverses.
- Entirely automatic in action, depending upon pressure and velocity of flow within the line to perform their functions of opening and closing
- The Crane D140 Bronze check valve is of the swing variety
- This valve carries the British Standards Institution kitemark

Materials

NO.	MATERIAL	SIZES
Body	Bronze BS EN 1982 CC491K	All
Cap	Bronze BS EN 1982 CC491K	All
Disc Holder	Brass BS EN 12164 CW614N	1/2 - 1
Disc Holder	Bronze BS EN 1982 CC491K	1 1/4 - 3
Disc	Nitrile Rubber	All
Disc Retaining Nut	Brass BS EN 12164 CW614N	1/2 - 2 1/2
Disc Retaining Nut	Bronze BS EN 1982 CC491K	3" only
Washer	Brass BS EN 12164 CW614N	1/2 - 2 1/2
Hinge	Bronze BS EN 1982 CC491K	All
Hinge Pin	Stainless Steel	1/2 - 2
Hinge Pin	Brass BS EN 12164 CW614N	2 1/2 & 3
Hinge Pin Plug	Brass BS EN 12164 CW614N	2 1/2 & 3
Hinge Nut	Brass BS EN 12164 CW614N	All
ID Plate	Aluminium	All
Drive Pin	Steel-Electro Brass	All

Dimensional Drawing

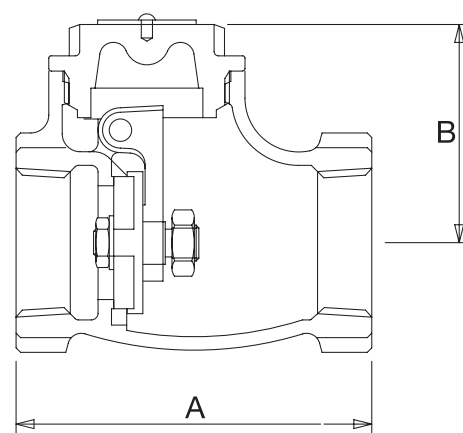

Dimensions & Weights

SIZE (inch)	WEIGHT (kg)	A (mm)	B (mm)
1/2	0.33	58	38
3/4	0.43	66	42
1	0.63	80	49
1 1/4	1.01	89	56
1 1/2	1.34	95	65
2	2.12	108	76
2 1/2	4.2	153	98
3	6.02	188	98

Pressure/Temperature Ratings

TEMPERATURE (°C)	-10 to 100
PRESSURE (BAR)	25

Intermediate pressure ratings shall be determined by interpolation.

PRESSURE RATING: PN25

TEMPERATURE OPERATING RANGE: -10 To 100°C

UK END CONNECTION: Taper threaded to BS EN 10226-2 (ISO 7-1) formerly BS 21

US END CONNECTION: ANSI B1.20.1 (please add suffix AT to denote American Thread)

OPERATOR: Swing Type Check Valve

SPECIFICATION: Valves are manufactured in accordance with BS 5154: 1991 PN25 for Series B ratings but are limited to 100°C maximum temperature.

This valve is not suitable for use on Group 1 gases or unstable fluids, as defined by the Pressure Equipment Directive 2014/68/EU*.

* See page 155 for more information

D142

Bronze Swing Check Valve

D142

PN32

Features & Benefits

- Check valves permit flow in one direction only and close automatically if flow reverses.
- Entirely automatic in action, depending upon pressure and velocity of flow within the line to perform their functions of opening and closing
- The Crane D142 bronze check valve is of the swing variety



Materials

NO.	MATERIAL	SIZES
Body	Bronze BS EN 1982 CC491K	1/4 - 3/4" 1 - 3"
Cap	Bronze BS EN 1982 CC491K	
Disc	Brass BS EN 12164 CW721R	
Disc	Bronze BS EN 1982 CC491K	
Hinge	Nut Brass BS 2874 CZ121	
Hinge	Pin/Plug DZR Brass BS EN 12164 CW602N	
Hinge	Bronze BS EN 1982 CC491K	
Drive Pin	Steel-Electro Brassed	
ID Plate	Aluminium	

Dimensional Drawing

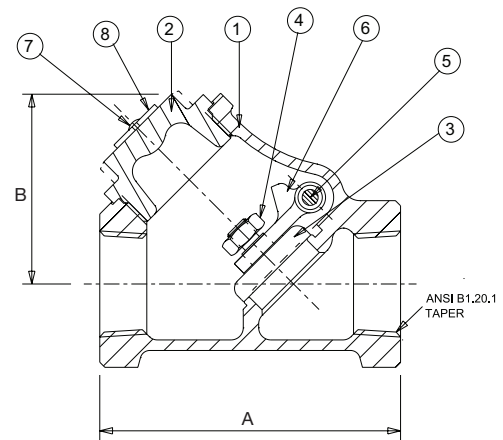

Dimensions & Weights

SIZE (inch)	WEIGHT (kg)	A (mm)	B (mm)
1/4	0.26	54	37
3/8	0.25	54	37
1/2	0.39	62	43
3/4	0.62	76	52
1	1.07	94	65
1 1/4	1.65	110	76
1 1/2	2.56	126	89
2	4.05	152	108
2 1/2	6.4	186	134
3	9.3	218	160

Pressure/Temperature Ratings

TEMPERATURE (°C)	-10 to 120	260
PRESSURE (BAR)	32	14

Intermediate pressure ratings shall be determined by interpolation.

PRESSURE RATING: PN32

TEMPERATURE OPERATING RANGE: -10 to 260°C

UK END CONNECTION: BS 21 Taper

US END CONNECTION: ANSI B1.20.1

OPERATOR: Swing Check, Screwed in Cap. Can be mounted vertically as long as flow is upwards

SPECIFICATION: Valves are manufactured in accordance with BS 5154 for Series A ratings. Design is of the Y-Pattern having flat regrindable swing disc and integral regrindable body seat. The disc is retained on the hinge by a locked nut and is free to swivel. The hinge pin is retained by an external threaded plug.

This valve is not suitable for use on Group 1 gases or unstable fluids, as defined by the Pressure Equipment Directive 2014/68/EU.*

* See page 155 for more information

D130W

Single Non-Return Valve



PN16

D130W



GENERAL VALVES

Features & Benefits

- Spring loaded axially guided disc
- Positive non-slam shut-off
- WRAS approved for use with wholesome (potable) water to 85°C
- Resilient seat

Materials

PART	MATERIAL	SPECIFICATION	
		BS EN	ASTM
Body	Cast Iron	1561 EN-GJL-250	A126 CLASS B
Disc	Cast Iron	1561 EN-GJL-250	A126 CLASS B
Seat	EPDM	-	-
Spring	Stainless Steel 304	1.4301	AISI 304
Stem	Stainless Steel 304	1.4301	AISI 304
Bushing	Brass	12164 CW611N	-
Bushing	Cast Iron	1561 EN-GJL-250	A126 CLASS B

Dimensional Drawing

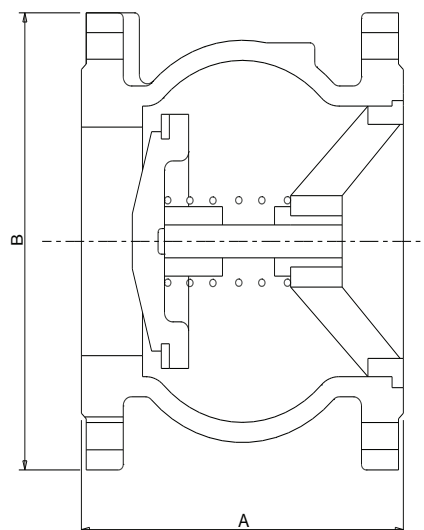

Dimensions & Weights

SIZE (DN)	A (mm)	B (mm)	WEIGHT (kg)
50	100	165	8
65	120	185	10
80	140	200	13
100	170	220	17
125	200	250	28
150	230	285	38
200	288	340	52
250	354	405	85
300	410	460	125

Note: These valves are not intended to be used as backflow prevention devices conforming to Schedule 2 Section 6 of the WRAS Water Regulations Guide.

PRESSURE / TEMPERATURE RATING: 16 bar from -10 to 120°C (WRAS to 85°C)

SPECIFICATION: Flanged to BS EN 1092-2 PN16.

D230W

Double Non-Return Valve

D230W

PN16

Features & Benefits

- 2 WRAS approved single non-return valves (to 85°C) bolted together
- Spring loaded axially guided disc
- Positive non-slam shut-off
- Resilient seat
- WRAS Approved fusion bonded epoxy internal and external coating



Materials

PART	MATERIAL	SPECIFICATION	
		BS EN	ASTM
Body	Cast Iron	1 EN-GJL-250	A126 CLASS B
Disc	Fusion Bonded Epoxy Cast Iron	1561 EN-GJL-250	A126 CLASS B
Seat	EPDM	-	-
Spring	Stainless Steel 304	1.4301	AISI 304
Stem	Stainless Steel 304	1.4301	AISI 304
Bushing	Brass	12164 CW611N	-
Guide	Cast Iron	1561 EN-GJL-250	A126 CLASS B
Gasket	EPDM (Shore 70) - WRAS Approved	-	-
Stud	Steel (Zinc Plated)	BS EN 3692 Grade 8.8	-
Nut	Steel (Zinc Plated)	BS EN 3692 Grade 8	-
Plug 1/4" RC	Stainless Steel 316/304	-	-

Dimensional Drawing

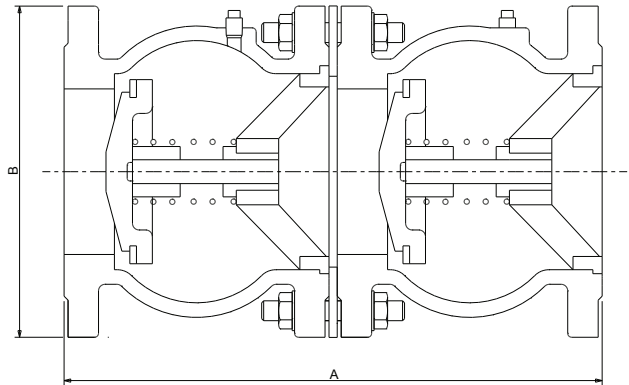

Dimensions & Weights

SIZE (DN)	A (mm)	B (mm)	WEIGHT (kg)
50	203	165	17
65	243	185	21
80	283	200	28
100	343	220	36
125	403	250	58
150	463	285	78
200	579	340	108
250	711	405	174
300	823	460	255

Please Note:

These valves are not intended to be used as backflow prevention devices conforming to Schedule 2 Section 6 of the WRAS Water Regulations Guide.

Title: Acceptability of two single check valves in place of a double check valve

Clause Reference: Schedule 2 paragraph 15(5) of the WRAS Water Regulations Guide

Two suitably approved single check valves (Type EA device) installed in series are accepted as offering the equivalent level of protection as that afforded by a double check valve (Type EC device) providing the maximum distance between the adjacent flanges of the valves did not exceed twice their nominal bore and the operation of one component does not interfere with the operation of the other.

PRESSURE / TEMPERATURE RATING: 16 bar from -10 to 120°C

SPECIFICATION: Flanged to BS EN 1092-2 PN16.

Valid as of 120220

Every effort has been made to ensure that the information contained in this publication is accurate at the time of publishing. Crane Ltd assumes no responsibility or liability for typographical errors or omissions or for any misinterpretation of the information within the publication and reserves the right to change without notice.

FM469

Cast Iron Check Valve with Resilient Seat

PN16

FM469



GENERAL VALVES

Features & Benefits

- Check valves permit flow in one direction only and close automatically if flow reverses
- Entirely automatic in action, depending upon pressure and velocity of flow within the line to perform their functions of opening and closing
- Swing pattern, bronze trim, resilient seated

Materials

PART	MATERIAL	SIZES
Body	Cast Iron BS EN 1561 GJL-250	All
Cap	Cast Iron BS EN 1561 GJL-250	All
Disc	Cast Iron BS EN 1561 GJL-250	All
Body Seat Ring	Bronze BS EN 1982 CC491K	All
Disc Ring	Nitrile Rubber	All
Hinge Pin Bush	Bronze BS EN 1982 CC491K	All
Hinge Pin Plug	Bronze BS EN 1982 CC491K	All
Hinge Pin	Stainless Steel Type 304	50 - 80
Hinge Pin	13% Cr.Steel AISI Type 410	100 - 300
Cap Bolts	Steel BS 3692 Gr.8.8	All
Cap Bolt Nuts	Steel BS 3692 Gr.8	All
Gasket	Asbestos Free	All
Body Plate	Aluminium	All
Disc Ring Retaining Nut	Cast Iron BS EN 1561 GJL-250	All
Retaining Nut Pin	Steel	All

Dimensional Drawing

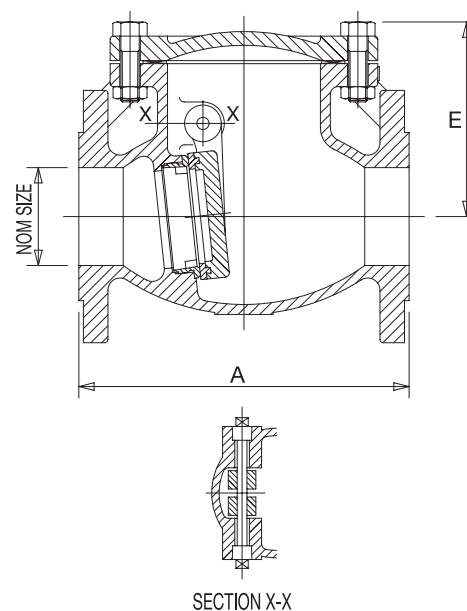

Dimensions & Weights

SIZE (mm)	WEIGHT (kg)	A (mm)	E (mm)
50	11.3	203	113
65	15.6	216	126
80	19.3	241	136
100	26.6	292	153
125	44	330	186
150	55.5	356	207
200	119	495	250
250	175	622	352
300	263	698	397

Pressure/Temperature Ratings

TEMPERATURE (°C)	-10 to 65
PRESSURE (BAR)	16

Intermediate pressure ratings shall be determined by interpolation.

PRESSURE RATING: PN16

TEMPERATURE OPERATING RANGE: -10 to 65°C

UK END CONNECTION: Flanged BS EN 1092-2 PN16

OPERATOR: Swing Check Valve

SPECIFICATION: Valves are manufactured in accordance with BS EN 12334:2001.

End flanges conform to BS EN 1092-2 Section 3.2 Table 11 with raised face and are normally supplied drilled.

This valve is not suitable for use on Group 1 gases or unstable fluids, as defined by the Pressure Equipment Directive 2014/68/EU.*

* See page 155 for more information

FM492

Cast Iron Check Valve

PN16

FM492



Features & Benefits

- Check valves permit flow in one direction only and close automatically if flow reverses
- Entirely automatic in action, depending upon pressure and velocity of flow within the line to perform their functions of opening and closing
- Swing pattern, metal faced disc

Materials

PART	MATERIAL	SIZES
Body	Cast Iron BS EN 1561 GJL-250	All
Cap	Cast Iron BS EN 1561 GJL-250	All
Disc	Cast Iron BS EN 1561 GJL-250	All
Body Seat Ring	Bronze BS EN 1982 CC491K	All
Disc Ring	Bronze BS EN 1982 CC491K	All
Hinge Pin Bush	Bronze BS EN 1982 CC491K	All
Hinge Pin Plug	Bronze BS EN 1982 CC491K	All
Hinge Pin	Stainless Steel Type 304	50 - 100
Hinge Pin	13% Cr.Steel AISI Type 410	125 - 300
Cap Bolts	Steel BS 3692 Gr.8.8	All
Cap Bolt Nuts	Steel BS 3692 Gr.8	All
Gasket	Asbestos Free	All
Body Plate	Aluminium	All

Dimensional Drawing

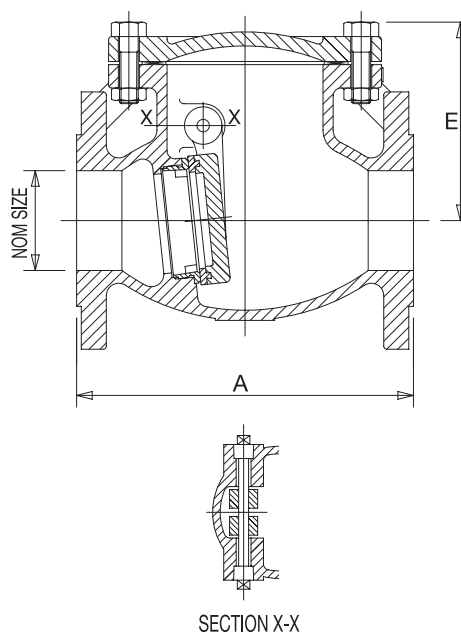

Dimensions & Weights

SIZE (mm)	WEIGHT (kg)	A (mm)	E (mm)
50	11.3	203	113
65	15.6	216	126
80	19.3	241	136
100	26.6	292	153
125	44	330	186
150	55.5	356	207
200	119	495	250
250	175	622	352
300	263	698	397

Pressure/Temperature Ratings

TEMPERATURE (°C)	-10 to 120	220
PRESSURE (BAR)	16	12.1

Intermediate pressure ratings shall be determined by interpolation.

PRESSURE RATING: PN16

TEMPERATURE OPERATING RANGE: -10 to 220°C

UK END CONNECTION: Flanged BS EN 1092-2

OPERATOR: Swing Type Check Valve

SPECIFICATION: Valves are manufactured in accordance with BS EN 12334: 2001.

End flanges conform to BS EN 1092-2 with raised face and are normally supplied drilled.

This valve is not suitable for use on Group 1 gases or unstable fluids, as defined by the Pressure Equipment Directive 2014/68/EU.*

* See page 155 for more information

F491

F491

Swing Check Valve

Class 100

Features & Benefits

- Check valves permit flow in one direction only and close automatically if flow reverses.
- Entirely automatic in action, depending upon pressure and velocity of flow within the line to perform their functions of opening and closing

Materials

NO.	PART	MATERIAL	SIZES
1	Body	Cast Iron BS EN 1561 GJL-250	-
2	Cover	Cast Iron BS EN 1561 GJL-250	-
3	Disc	Cast Iron BS EN 1561 GJL-250	-
4	Body Seat Ring	Bronze BS EN 1982 CC491K	-
5	Disc Face Ring	Bronze BS EN 1982 CC491K	-
6	Hinge Pin Bush	Bronze BS EN 1982 CC491K	-
7	Hinge Pin Plug	Bronze BS EN 1982 CC491K	-
8	Hinge Pin	Stainless Steel Type 304	2 - 4
8	Hinge Pin	13% CR Steel Type 410	5 - 12
9	Cover Bolt	Steel BS 3692 Grade 8.8	-
10	Cover Bolt Nut	Steel BS 3692 Grade 8	-
11	Gasket	Asbestos Free Garlock 2850	-
12	Body Plate	Aluminium	-

Dimensions & Weights

SIZE (inch)	WEIGHT (kg)	A (mm)	B (mm)	C (mm)	D (mm)	E (mm)
2	11.3	203	152	16	153	113
2½	15.6	216	178	17	175	126
3	19.3	241	191	19	195	136
4	26.6	292	229	24	225	153
5	44.0	330	254	24	273	186
6	55.5	356	279	25	310	207
8	119.0	495	343	29	365	250



Dimensional Drawing

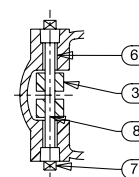
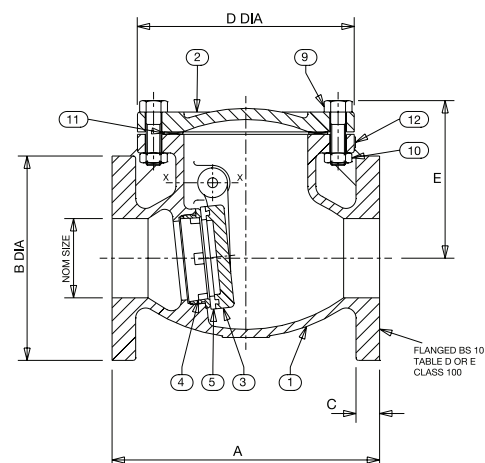

SECTION X - X

PRESSURE RATING: Class 100

TEMPERATURE OPERATING RANGE: -10 to 232°C

UK END CONNECTION: Flanged BS10 Table D or E

OPERATOR: Swing Check Valve

SPECIFICATION: Valves are manufactured in accordance with BS 5153.

Flanges are flat faced and drilled to BS 10 Table D or E.

This valve is not suitable for use on Group 1 gases or unstable fluids as defined by the Pressure Equipment Directive 2014/68/EU.*

* See page 155 for more information

F493

Cast Iron Check Valve

Class 125

F493



Features & Benefits

- The F493 is a swing check valve with a Bronze trim
- Manufactured to BS 5153:1974

Materials

PART	MATERIAL	SIZES
Body	Cast Iron BS EN 1561 GJL-250	All
Cap	Cast Iron BS EN 1561 GJL-250	All
Disc	Cast Iron BS EN 1561 GJL-250	All
Body Seat Ring	Bronze BS EN 1982 CC491K	All
Disc Ring	Bronze BS EN 1982 CC491K	All
Hinge Pin Bush	Bronze BS EN 1982 CC491K	All
Hinge Pin Plug	Bronze BS EN 1982 CC491K	All
Hinge Pin	Stainless Steel Type 304	2 - 4
Hinge Pin	13% Cr.Steel AISI Type 410	5 - 12
Cap Bolts	Steel BS 3692 Gr.8.8	All
Cap Bolts Nuts	Steel BS 3692 Gr.8	All
Gasket	Asbestos Free	All
Body Plate	Aluminium	All

Dimensional Drawing

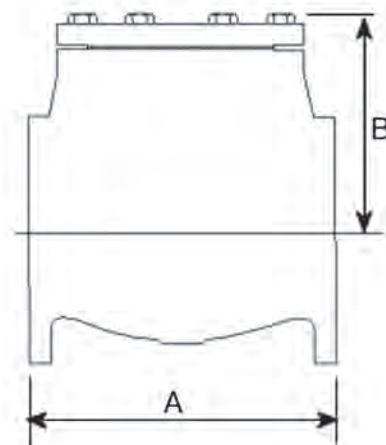

Dimensions & Weights

SIZE (inch)	WEIGHT (kg)	A (mm)	B (mm)
2	11.3	203	113
2 1/2	15.6	216	126
3	19.3	241	136
4	26.6	292	153
5	44	330	186
6	55.5	356	207
8	119	495	250
10	175	622	352
12	263	698	397

Pressure/Temperature Ratings

TEMPERATURE (°C)	-10 to 65	150	230
PRESSURE (BAR)	13.8	11.4	8.6

Intermediate pressure ratings shall be determined by interpolation.

PRESSURE RATING: Class 125

TEMPERATURE OPERATING RANGE: -10 to 230°C

US END CONNECTION: ANSI Class 125

OPERATOR: Swing Check Valve

SPECIFICATION: Valves are manufactured in accordance with BS 5153:1974

and also meet the requirements of MSS.SP-71. End flanges conform to BS 1560. Section 3.2/ANSI B16.1 Class 125 with flat face and are normally supplied drilled.

This valve is not suitable for use on Group 1 gases or unstable fluids, as defined by the Pressure Equipment Directive 2014/68/EU.*

* See page 155 for more information

FM463 / FM466 / FA463

FM463

Check Valves

PN16 / PN25 / ANSI125

Features & Benefits

- Check valves permit flow in one direction only and close automatically if flow reverses, depending upon pressure and velocity of flow to perform the functions of the opening and closing.
- Non-Slam design as a result of rubber seat and spring-assisted closure.
- EPDM rubber seat to facilitate quiet operation and improve disk seating.
- Eyebolt tapped holes in sizes DN200 and above, to fit bolts to BS EN ISO 3226:2010 (eyebolts are not supplied with product).
- Design and construction lends itself to pump duty applications.

Materials

NO.	PART	MATERIAL
1	Body	Cast Iron EN-GJL-250 PN16/ANSI125 DN50-DN150 Ductile Iron EN-JGS-400-15 PN16/ANSI125 DN200-DN600 Ductile Iron EN-JGS-400-15 PN25 DN50-DN600
2	Disc	Stainless Steel SS304
3	ID Plate	Anodised Aluminium
4	Seat	EPDM Max 120°C
5	Stop Bolt	Stainless Steel 304
6	Stem	Stainless Steel 304
7	Spring	Stainless Steel 304
8	Washer	PTFE
9	Gasket	EPDM Max 120°C

Dimensions & Weights

SIZE	A (mm)		B (mm)	F (mm)	H (mm)	WEIGHT (Kg)	EYEBOLT TAPPING (To BS EN 3226:2010)	Kv VALUES
	PN16	ANSI 125						
DN50	107	102	66.0	10.0	43.0	1.5	N/A	44
DN65	127	121	80.5	16.0	46.0	2.2	N/A	102
DN80	142	133	95.0	15.0	64.0	3.2	N/A	128
DN100	162	171	119.0	28.0	64.0	4.1	N/A	203
DN125	192	193	146.0	38.0	70.0	5.7	N/A	528
DN150	218	219	171.0	47.0	76.0	8.2	N/A	688
DN200	273	276	224.5	70.0	89.0	14.6	M8	1315
DN250	328	336	266.0	78.0	114.0	24.2	M10	2315
DN300	382	406	311.0	104.0	114.0	35.8	M10	3623
DN350	442	448	360.0	127.0	127.0	54.0	M12	4620
DN400	495	511	410.0	143.0	140.0	76.0	M12	5166
DN450	555	546	450.0	158.0	152.0	103.0	M16	6164
DN500	617	603	505.0	183.0	152.0	126.0	M16	9670
DN600	734	714	624.0	221.0	178.0	187.0	M16	15340

Dimensional Drawing

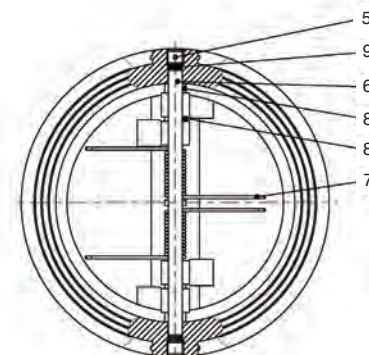
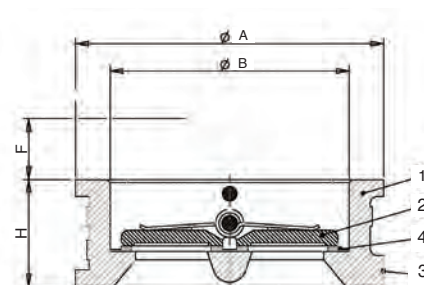

Selection

FIG NO.	FM463	FM466	FA463
PRESSURE RATING	PN16	PN25	ANSI125

PRESSURE RATING: FM463: PN16, FA463: ANSI 125, FM466: PN25

TEMPERATURE OPERATING RANGE: -10 to 120°C

UK END CONNECTION: Suitable for flange connection to BS EN 1092-2 PN16 / BS EN 1092-2 PN25

US END CONNECTION: BS 1560, ANSI B16.1, ANSI B16.5

SPECIFICATION: Designed in accordance with BS 5153 (FA463) and BS EN 12334 (FM463, FM466). Face-to-face dimensions conform to BS EN 558 series 16. Suitable for installation in vertical and horizontal pipelines.

When installed in vertical pipelines the flow must be in an upward direction.

This valve is suitable for use on Group 2 liquids only, as defined by the Pressure Equipment Directive 2014/68/EU.*

* See page 155 for more information

Every effort has been made to ensure that the information contained in this publication is accurate at the time of publishing. Crane Ltd assumes no responsibility or liability for typographical errors or omissions or for any misinterpretation of the information within the publication and reserves the right to change without notice.

147XU

Swing Check Valve

Class 150

147XU

Features & Benefits

- Cast Steel, bolted cap and flanged
- Swing check valves prevent reversal of flow through the pipeline
- Can be installed in horizontal or vertical, upward flow piping
- Offer low resistance to flow and are particularly suited to low velocity service
- Seat ring is seal welded to eliminate leak paths



Materials

PART	MATERIAL
Body	A216 WCB
Cap	A216 WCB
Seat Ring	Hardfaced
Disc	13% CR Overlay
Hinge	WCB
Pins, Hinge	410 SS
Disc Washer	Steel
Cap Screw	A307 Gr. B
Cap Gasket	Soft Iron
Cap Studs	A193 Gr. B7
Cap Nuts	A194 Gr. 2H
ID Tags	SS
ID Pins	Steel

Dimensional Drawing

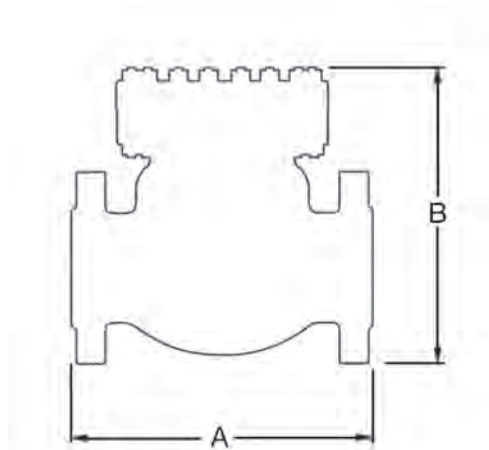

Dimensions & Weights

SIZE (inch)	WEIGHT (lbs)	A (inch)	B VALVE OPEN (inch)
2	33	8.00	6.75
2 1/2	57	8.50	7.12
3	59	9.50	7.38
4	93	11.50	8.50
6	165	14.00	10.25
8	275	19.50	11.88
10	440	24.50	13.88
12	680	27.50	15.75
14	950	31.00	17.75
16	1225	34.00	19.00
18	1700	38.50	21.25
20	1850	38.50	23.58
24	2900	51.00	26.75

Industry Standards

STEEL VALVES	ANSI B16.34
FACE-TO-FACE/END-TO-END	ANSI B16.10
FLANGE DIMENSIONS	ANSI B16.5
TESTING	API 598
ACCEPTANCE	API RP591

Intermediate pressure ratings shall be determined by interpolation.

SIZE RANGE: 2 - 24 inches

PRESSURE RATING: Class 150

Carbon Steel

ASTM A216 Grade WCB

285 psi @ -20°F to 100°F

SPECIFICATION: Swing check valves prevent reversal of flow through pipelines.

Most Crane FS swing check valves can be installed in horizontal or vertical upward flow piping. They offer low resistance to flow and are particularly suited to low velocity service.

159XU

Swing Check Valve

Class 300

Features & Benefits

- Cast Steel, bolted cap and flanged
- Swing check valves prevent reversal of flow through the pipeline
- Can be installed in horizontal or vertical, upward flow piping
- Offer low resistance to flow and are particularly suited to low velocity service
- Seat ring is seal welded to eliminate leak paths

Materials

PART	MATERIAL
Body	A216 WCB
Bonnet	A216 WCB
Seat Ring	Hardfaced
Disc	13% CR Overlay
Hinge	WCB
Pins, Hinge	410 SS
Cap Screw	A307 Gr. B
Cap Gasket	Spiral Wound
Cap Studs	A193 Gr. B7
Cap Nuts	A194 Gr. 2H
ID Tags	SS
ID Pins	Steel

Dimensions & Weights

SIZE (inch)	WEIGHT (lbs)	A (inch)	B VALVE OPEN (inch)
2	46	10.50	6.75
2½	66	11.50	7.38
3	86	12.50	8.50
4	154	14.00	9.25
6	276	17.50	11.88
8	420	21.00	13.38
10	640	24.50	13.88
12	1000	28.00	16.62
14	1550	33.00	18.88
16	1700	34.00	20.50
18	2200	38.50	23.62
20	2800	44.00	26.38
24	3650	53.00	29.62

SIZE RANGE: 2 - 24 inches
PRESSURE RATING: Class 300
 Carbon Steel
 ASTM A216 Grade WCB
 740 psi @ -20°F to 100°F

SPECIFICATION: Swing check valves prevent reversal of flow through pipelines. Most Crane FS swing check valves can be installed in horizontal or vertical upward flow piping. They offer low resistance to flow and are particularly suited to low velocity service.



GENERAL VALVES

Dimensional Drawing

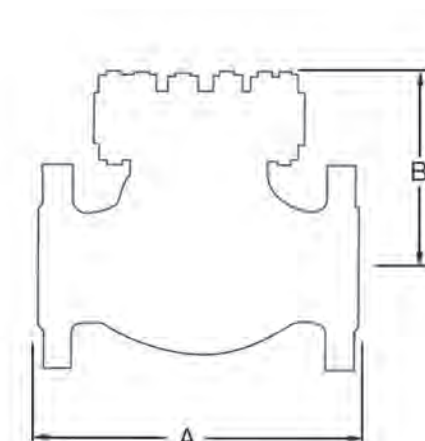

Industry Standards

STEEL VALVES	ANSI B16.34
FACE-TO-FACE/END-TO-END	ANSI B16.10
FLANGE DIMENSIONS	ANSI B16.5
TESTING	API 598
ACCEPTANCE	API RP591

Intermediate pressure ratings shall be determined by interpolation.

PROJECT

M&S - Carmine Building

Also known as No. 5 Merchant Square, the Carmine Building overlooks the canal which runs through Paddington and is part of a large area of regeneration in West London. Marks & Spencers have leased seven of the 15 floors as additional office space, as it conveniently sits adjacent to the retailers' current Waterside House headquarters.

The Crane Fluid Systems Dominators provide heating, ventilation and air conditioning throughout the building. These are a compact prefabricated unit that combine a control valve, flow measurement device, bypass valves, strainer and drain, ready for simple and fast on-site connection to fan coils and other terminal units.

All the components are supplied as one tested unit with a known performance, which minimises specification risks and saves valuable time. For contractors, Imtech Meica, installation of Dominators provides significant reduction in site labour and installation costs because connection is fast and simple. There is a range of standard Dominator units available and these can also be tailor-made to suit specific needs.

LOCATION:

Paddington,
London

ARCHITECT:

Mossessian
& Partners

HVAC

CONTRACTOR:

Imtech Meica

DISTRIBUTOR:

BSS (Romford)

SPECIFICATION:

Dominators



the
waterline

A new square for the
West End with space
to work, to live, to enjoy.

Draw-Off Cocks / Drain Taps

Fitting Crane Fluid System's Drain Taps and Gland Cocks enable systems to be drained without removing pipework. They prevent the build up of sediment that flows through the pipework thus extending its life expectancy.

Fig. No.	PN Rating	End Connections	Size Range	Body Material
D340†	16	Threaded Inlet	1/2 - 1"	Bronze
D341†	16	Threaded Inlet	1/2 - 1"	Bronze
D344	10	Male Hose Union	3/8 - 2"	Bronze

† WRAS approved product

D341



D344

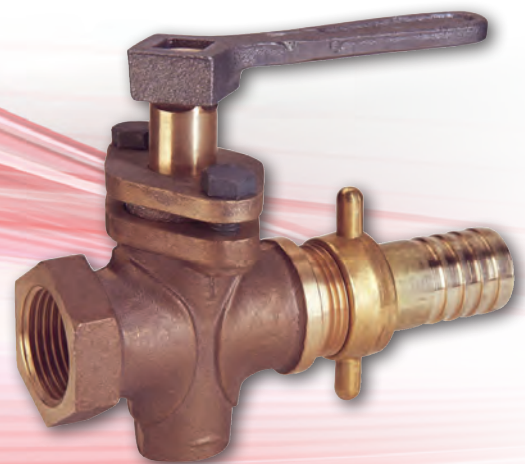

D340

Bronze Draining Tap



PN16

D340



GENERAL VALVES

Features & Benefits

- Bronze draining taps are suitable for use on hot and cold water up to 16bar, at temperatures up to 110°C
- Enables system to be drained without removing pipework
- Prevents build-up of sediment and extends life expectancy of pipework
- The inlet is a threaded taper male connection to BS EN 10226-2
- The outlet is ribbed for hose connection
- WRAS Approved up to 85°C

Materials

NO.	NAME	MATERIAL
1	Body	Bronze BS EN 1982 CC491K
2	Stem	Brass BS EN 12164 CW614N
3	Bonnet	Brass BS EN 12164 CW614N
4	Disc Holder	Brass BS EN 12164 CW614N
5	Rubber Seat	EP80 (EPDM-WRAS Approved)
6	Stem Packing	EP70 (EPDM-WRAS Approved)
7	Nut (1" Only)	Brass BS EN 12164 CW614N

Dimensions, Coefficients & Weights

SIZE (inch)	A (mm)	B (mm)	C (mm)	D (mm)	E (mm)	F (mm)	WEIGHT (kg)
1/2	54.2	7.4	7.7	9.8	59	54.2	0.13
3/4	64.4	7.5	8.5	11.5	68.8	61.7	0.26
1	78.7	7.15	9.3	11.5	87.8	79.5	0.59

Dimensional Drawing

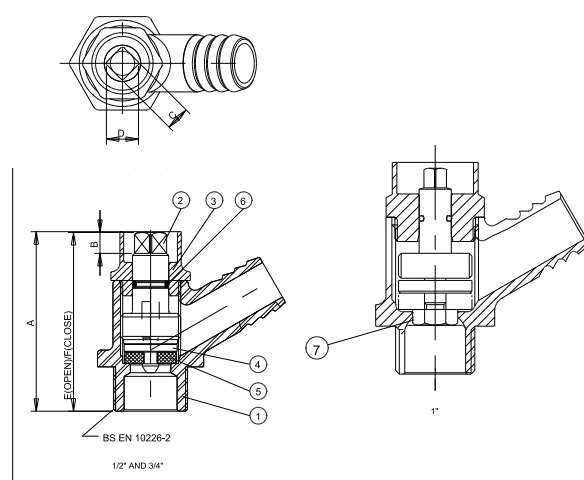
**PRESSURE RATING:** PN16**TEMPERATURE OPERATING RANGE:** 0 to 110°C**UK END CONNECTION:** BS EN 10226-2 Taper**OPERATOR:** Lockshield**SPECIFICATION:** Sizes 1/2" and 3/4" draining taps are designed and manufactured in accordance with BS 2879 type 2.

This valve is excluded from the requirements of the Pressure Equipment Directive 2014/68/EU

Valid as of 300519

Every effort has been made to ensure that the information contained in this publication is accurate at the time of publishing. Crane Ltd assumes no responsibility or liability for typographical errors or omissions or for any misinterpretation of the information within the publication and reserves the right to change without notice.

D341

Bronze Draining Tap



D341



Features & Benefits

- Bronze draining taps are suitable for use on hot and cold water up to 16bar, at temperatures up to 110°C
- Enables system to be drained without removing pipework
- Prevents build-up of sediment and extends life expectancy of pipework
- The inlet is a threaded taper male connection to BS EN 10226-2
- The outlet is ribbed for hose connection
- WRAS Approved up to 85°C

Materials

NO.	NAME	MATERIAL
1	Body	BRONZE BS EN 1982 CC491K
2	Stem	BRASS BS EN 12164 CW614N
3	Bonnet	BRASS BS EN 12164 CW614N
4	Disc Holder	BRASS BS EN 12164 CW614N
5	Rubber Seat	EP80 (EPDM WRAS APPROVED)
6	Stem Packing	EP70 (EPDM WRAS APPROVED)
7	Nut (1" Only)	BRASS BS EN 12164 CW614N

Dimensional Drawing

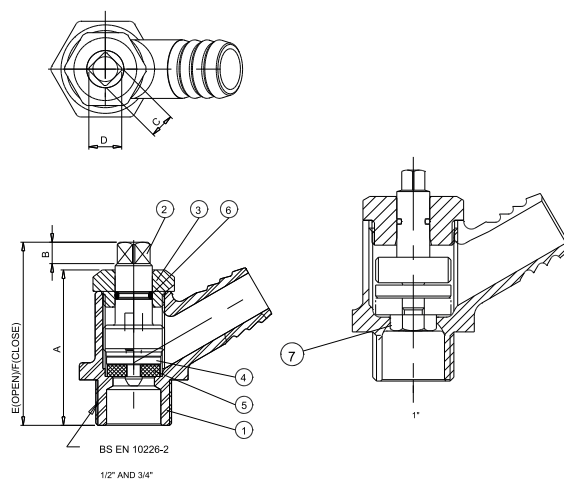

Dimensions, Coefficients & Weights

SIZE (inch)	A (mm)	B (mm)	C (mm)	D (mm)	E (mm)	F (mm)	WEIGHT (kg)
1/2	44.2	7.4	7.7	9.8	59	54.2	0.13
3/4	54.4	7.5	8.5	11.5	68.8	61.7	0.26
1	70.7	7.15	9.3	11.5	87.9	78.7	0.59

PRESSURE RATING: PN16

TEMPERATURE OPERATING RANGE: 0 to 110°C

UK END CONNECTION: BS EN 10226-2 Taper

OPERATOR: Loose Key Operation

SPECIFICATION: Sizes 1/2" and 3/4" draining taps are designed and manufactured in accordance with BS 2879 type 2.

This valve is excluded from the requirements of the Pressure Equipment Directive 2014/68/EU.

Valid as of 300519

Every effort has been made to ensure that the information contained in this publication is accurate at the time of publishing. Crane Ltd assumes no responsibility or liability for typographical errors or omissions or for any misinterpretation of the information within the publication and reserves the right to change without notice.

D344

Bronze Gland Pattern Draw-off Cock

PN10*

Features & Benefits

- Straight type, gland pattern
- *The D344 is suitable for use on pressure up to 8.6 bar and at temperatures up to 110°C

Materials

NO.	PART	MATERIAL	SIZES
1	Body	Bronze BS EN 1982 CC491K	All
2	Plug	Bronze BS EN 1982 CC491K	All
3	Gland	Bronze BS EN 1982 CC491K	All
4	Hose Unions	Brass	All
5	Lever	Malleable Iron	All

Dimensions & Weights

SIZE (inch)	WEIGHT (kg)	A (mm)	B (mm)
1/2*	0.45	114	77
3/4	0.7	136	94
1	1.2	150	114
1 1/4	2.01	170	135
1 1/2	2.61	204	146
2	4.14	240	170

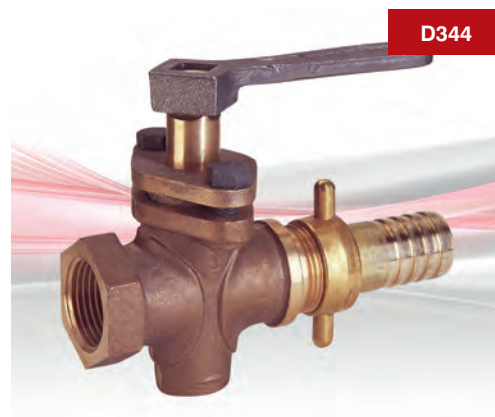

GENERAL VALVES

Dimensional Drawing

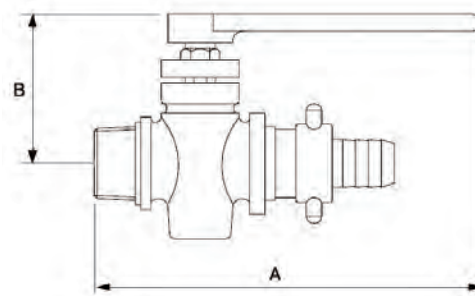

PRESSURE RATING: PN10

TEMPERATURE OPERATING RANGE: -10 to 110°C

UK END CONNECTION: Not Specified

OPERATOR: Lever Operated

SPECIFICATION: Sizes 1/2" and 3/4", gland pattern, inlet threaded female BS 21 (ISO 7), outlet threaded male BS 2779 (ISO 228) parallel with hose union.

Fixed key.

Each draw-off cock is hydraulically tested at 20 bar.

This valve is excluded from the requirements

NOTE: All sizes come with a handle except 1/2 inch where a handle is not available.

Every effort has been made to ensure that the information contained in this publication is accurate at the time of publishing. Crane Ltd assumes no responsibility or liability for typographical errors or omissions or for any misinterpretation of the information within the publication and reserves the right to change without notice.

Valid as of 270719

Gate Valves

D151



Crane Fluid System gate valves offer the ultimate in dependable service wherever minimum pressure drop is important.

They serve as efficient stop valves with fluid flow in either direction. The straight through design offers little resistance to flow and reduces pressure drop to a minimum.

A gate-like disc - actuated by a stem screw and handwheel - moves up and down at right

angles to the path of flow, and seats against two seat faces to shut off the flow. Gate valves are not recommended for throttling since the control characteristic is not appropriate and subsequent damage, due to erosion, may prevent the valve providing an effective shut off.

Fig. No.	PN Rating	End Connections	Size Range	Bonnet Pattern	Wedge Material	Body Material	Operation
D151†	20	Threaded	1/4 - 4"	Threaded	Bronze	Bronze	Handwheel
D151A	20	Threaded	1/4 - 3"	Threaded	DZR Brass	DZR Btass	Handwheel
D151X	25	Threaded	1/4 - 3"	Threaded	Bronze	Bronze	Handwheel
D155C	16	Compression	15 - 54mm	Threaded	Bronze	Bronze	Handwheel
D156	16	Threaded	1/4 - 4"	Threaded	Brass	Brass	Handwheel
D159	32	Threaded	1/4 - 3"	Threaded	Bronze	Bronze	Handwheel
D160	Class 100	Flanged	3/4 - 3"	Threaded	Bronze	Bronze	Handwheel
DM160	16	Flanged	1/4 - 3"	Threaded	Bronze	Bronze	Handwheel
D161	25	Flanged	3/4 - 3"	Threaded	Bronze	Bronze	Handwheel
DM161	25	Flanged	1/4 - 3"	Threaded	Bronze	Bronze	Handwheel
D162	Class 150	Flanged	3/4 - 3"	Threaded	Bronze	Bronze	Handwheel
D166	32	Threaded	1/4 - 3"	Threaded	Bronze	Bronze	Handwheel
D180	32	Threaded	1/4 - 3"	Union	Bronze	Bronze	Handwheel
D235	32	Threaded	1/2 - 2"	Threaded	Bronze	Bronze	Lockshield
D237†	20	Threaded	1/2 - 3"	Threaded	Bronze	Bronze	Lockshield
D237A	20	Threaded	1/2 - 2"	Threaded	DZR Brass	DZR Btass	Lockshield
D255C†	16	Compression	15 - 54mm	Threaded	Bronze	Bronze	Lockshield
F52	Class 100	Flanged	2 - 12"	Bolted	Cast Iron	Cast Iron	Handwheel
F53	Class 125	Flanged	2 - 12"	Bolted	Cast Iron	Cast Iron	Handwheel
F54	Class 100	Flanged	2 - 12"	Bolted	Cast Iron	Cast Iron	Handwheel
F58	Class 125	Flanged	2 - 12"	Bolted	Cast Iron	Cast Iron	Handwheel
F59	Class 125	Flanged	2 - 10"	Bolted	Cast Iron	Cast Iron	Handwheel
F84	Class 125	Flanged	2 - 12"	Bolted	Cast Iron	Cast Iron	Handwheel
FM52	6	Flanged	50 - 300mm	Bolted	Cast Iron	Cast Iron	Handwheel
FM57	10	Flanged	50 - 300mm	Bolted	Cast Iron	Cast Iron	Handwheel
FM63	16	Flanged	65 - 300mm	Bolted	Cast Iron	Cast Iron	Handwheel
FM82	16	Flanged	50 - 300mm	Bolted	Cast Iron	Cast Iron	Handwheel
33XU-F	Class 300	Flanged	2 - 24"	Bolted	Steel	Cast Steel	Handwheel
47XU-F	Class 150	Flanged	2 - 24"	Bolted	Steel	Cast Steel	Handwheel

† WRAS approved product

D151

Bronze Gate Valve



Sizes 1/2"-2" only

PN20

D151

GENERAL VALVES



Features & Benefits

- Crane gate valves offer the ultimate in dependable service wherever minimum pressure drop is important
- The D151 carries the British Standards Institution kitemark - your assurance of exacting quality standards
- WRAS approved for use on wholesome (potable) water in sizes 1/2" – 2" only
- WRAS approval temperature 85°C max

Materials

PART	MATERIAL	SIZES
Body	Bronze BS EN 1982 CC491K	All
Bonnet	Bronze BS EN 1982 CC491K	All
Stem	DZR Brass BS EN 12164 CW602N	1/4 - 3
Stem	Manganese Bronze	4
Disc	Bronze BS EN 1982 CC491K	All
Stem Retainer	DZR Brass BS EN 12164 CW602N	1/2 - 2
Stuffing Box	DZR Brass BS EN 12164 CW602N	1/4, 3/8, 2 1/2 & 3
Stuffing Box	Bronze BS EN 1982 CC491K	4
Packing	Asbestos Free	All
Packing Gland	Brass BS EN 12164 CW614N	1/4, 3/8, 1 - 3
Packing Gland Nut	Brass BS EN 12164 CW614N	1/2 & 3/4
Packing Gland	Bronze BS EN 1982 CC491K	4
Packing Nut	Brass BS EN 12164 CW614N	1/4 - 3
Packing Nut	Bronze BS EN 1982 CC491K	4
Handwheel	Aluminium	1/4 - 3
Handwheel	Malleable Iron BS EN 1562 GJMB-300-6	4
ID Plate	Aluminium	All
Handwheel Nut	Brass BS EN 12164 CW614N	All
Gasket	Asbestos Free	3 - 4

Dimensional Drawing

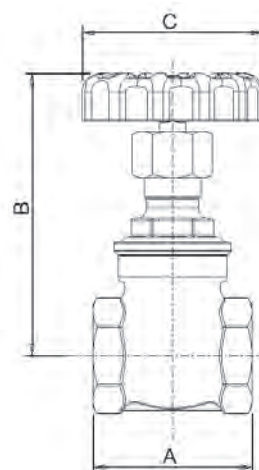

Dimensions & Weights

SIZE (inch)	WEIGHT (kg)	A (mm)	B (mm)	C (mm)
1/4	0.27	46	75	45
3/8	0.26	46	75	45
1/2	0.269	50	78	52.5
3/4	0.384	54	84	52.5
1	0.593	62	105	65
1 1/4	0.844	71	111	70
1 1/2	1.266	77.5	130	78
2	1.881	87.5	153	92
2 1/2	4.37	96	219	121
3	6.4	105	259	121
4	19.7	162	366	203

Pressure/Temperature Ratings

TEMPERATURE (°C)	-10 to 100	180
PRESSURE (BAR)	20	8

Intermediate pressure ratings shall be determined by interpolation.

PRESSURE RATING: PN20**TEMPERATURE OPERATING RANGE:** -10 to 180°C**UK END CONNECTION:** Taper threaded to BS EN 10226-2 (ISO 7-1) formerly BS 21**US END CONNECTION:** ANSI B1.20.1**OPERATOR:** Handwheel.

Gate valves are best for services that require infrequent valve operation, and where the disc is kept either fully opened or fully closed. They are not practical for throttling.

SPECIFICATION: Solid wedge disc, non-rising stem, screwed in bonnet. Valves are manufactured in accordance with BS EN 12288: 2010 PN20. Series B and are BSI Kitemark approved.

This valve is not suitable for use on Group 1 gases or unstable fluids, as defined by the Pressure Equipment Directive 2014/68/EU.*

* See page 155 for more information

D151A

DZR Gate Valve

PN20

D151A



Features & Benefits

- Crane gate valves offer the ultimate in dependable service wherever minimum pressure drop is important

Materials

PART	MATERIAL	SIZES
Body	DZR Brass BS EN 12165 CW602N	All
Bonnet	DZR Brass BS EN 12165 CW602N	All
Stem	DZR Brass BS EN 12165 CW602N	All
Packing Nut	Brass BS EN 12164 CW617N	All
Packing	PTFE	All
Stem Bush	DZR Brass BS EN 12165 CW602N	All
Disc	DZR Brass BS EN 12165 CW602N	All
Handwheel	Aluminium	All
Handwheel Nut	Steel (Zinc Plated)	All

Dimensional Drawing

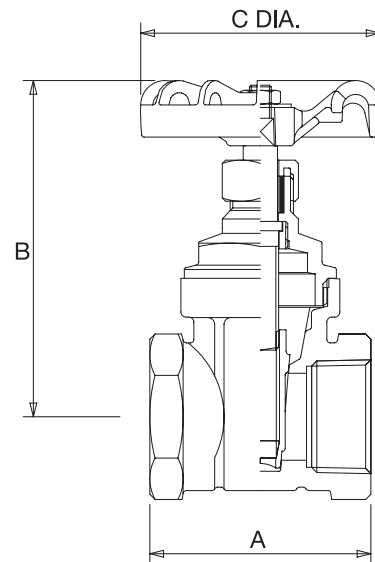

Dimensions & Weights

SIZE (inch)	WEIGHT (kg)	A (mm)	B (mm)	C (mm)
1/4	0.2	43	69	45
3/8	0.19	43	69	45
1/2	0.23	50	69	45
3/4	0.36	54	79	52
1	0.5	62	92	52
1 1/4	0.82	70	108	65
1 1/2	1.08	72	125	70
2	1.83	88	150	92
2 1/2	2.9	97	176	103
3	3.97	111	204	120

Pressure/Temperature Ratings

TEMPERATURE (°C)	-10 to 100	180
PRESSURE (BAR)	20	9

Intermediate pressure ratings shall be determined by interpolation.

PRESSURE RATING: PN20

TEMPERATURE OPERATING RANGE:
-10 to 180°C

END CONNECTION: Taper threaded to BS EN 10226-2 (ISO 7-1) formerly BS 21

OPERATOR: Handwheel.

Gate valves are best for services that require infrequent valve operation, and where the disc is kept either fully opened or fully closed. They are not practical for throttling.

SPECIFICATION: Valves are manufactured in accordance with BS EN 12288: 2010 PN20 for Series B ratings. Non-Rising Stem.

This valve is not suitable for use on Group 1 gases or unstable fluids, as defined by the Pressure Equipment Directive 2014/68/EU.*

* See page 155 for more information

D151X

Bronze Gate Valve

PN25

Features & Benefits

The D151X bronze gate valve offers a dependable and long service life across a wide variety of applications by virtue of its design and material composition.

- Non-rising stem design to minimise installation height
- Full bore design to ensure minimal pressure drop
- Adjustable gland packing for ease of maintenance
- Material selection results in superior dezincification (DZR) and corrosion resistance properties
- Body, bonnet and disc are made from low lead content bronze, typically 4-6%

Materials

PART	MATERIAL	SPECIFICATION	SIZES
Body	Bronze	BS EN 1982 (CC491K)	ALL
Bonnet	Bronze	BS EN 1982 (CC491K)	ALL
Stem	DZR Brass	BS EN 12164 CW602N	ALL
Disc	Bronze	BS EN 1982 (CC491K)	ALL
Stem Retainer	DZR Brass	BS EN 12164 CW602N	1/2 - 2
Stuffing Box	DZR Brass	BS EN 12164 CW602N	1/4 - 3/8, 2 1/2 - 3
Packing Ring	PTFE	-	ALL
Packing Nut	Brass	BS EN 12164 CW614N	ALL
Packing Gland	Brass	BS EN 12164 CW614N	1/4 - 3/8, 1 - 3
Handwheel	Aluminium	-	ALL
Identification Plate	Aluminium	-	ALL
Handwheel Nut	Brass	BS EN 12164 CW614N	ALL
Gasket	Asbestos Free	-	3

Dimensions & Weights

SIZE (inch)	A (mm)	B (mm)	C (mm)	D (mm)	WEIGHT (kg)	KV
1/4	46	75	45	86.7	0.27	-
3/8	46	75	45	86.7	0.26	-
1/2	50	78	52.3	93.0	0.27	21
3/4	54	84	60	103	0.38	39
1	62	105	65	127	0.59	66
1 1/4	71	111	70	139	0.89	116
1 1/2	77.5	130	78	163	1.31	162
2	87.5	153	92	193	2.09	281
2 1/2	106	235	103	286.2	5.62	411
3	113	251	121	310.3	7.89	635

PRESSURE RATING: PN25

TEMPERATURE OPERATING RANGE:
-10 to 186°C

UK END CONNECTION:

FIG. D151X: Taper threaded to
BS EN 10226-2 (ISO 7-1) formerly BS 21

US END CONNECTION:

FIG. D151X.AT: ANSI B1.20.1

OPERATOR: Handwheel.

Gate valves are best for services that require infrequent valve operation, and where the disc is kept either fully opened or fully closed. They are not practical for throttling.

SPECIFICATION: The valve body, bonnet and disc shall be of Bronze to BS EN 1982 CC491K. The stem shall be of DZR Brass to BS EN 12164 CW602N. Operation shall be by hand wheel. Ends to be threaded to BS EN 10226-2. The valve is to be rated at PN25 and manufactured in accordance with BS EN 12288: 2010.

The Non-Rising Stem Gate Valves are unsuitable for use on Group 1 gases or unstable fluids, as defined by the Pressure Equipment Directive 2014/68/EU.



D151X

Please note: the photograph & dimensional drawing denotes sizes 1/2" - 2" only.

Dimensional Drawing

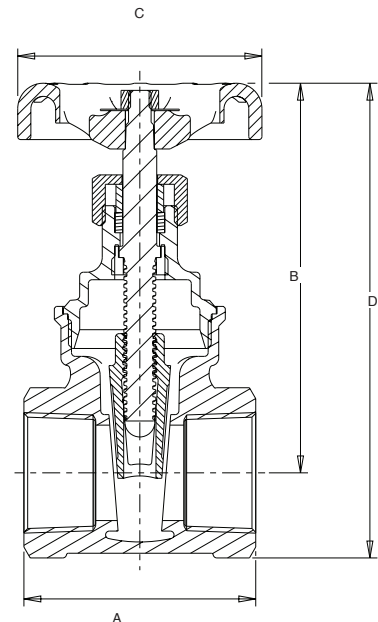

Pressure/Temperature Ratings

TEMPERATURE (°C)	-10 to 66	120	170	186
PRESSURE (BAR)	25.0	21.8	12.8	10.5

Intermediate pressure ratings shall be determined by interpolation.

D155C

Gate Valve



PN16

D155C



Features & Benefits

- Robust and high quality bronze body with integral seating surfaces
- Offers the ultimate in dependable service wherever minimum pressure drop is important
- WRAS approved for use with wholesome (potable) water
- Inside screw pattern with non-rising stem

Materials

PART	MATERIAL
Body	Bronze BS EN 1982 CC491K
Bonnet	Bronze BS EN 1982 CC491K
Stem DZR	Brass BS EN 12164 CW602N
Disc	Bronze BS EN 1982 CC491K
Stem Retainer	DZR Brass BS EN 12164 CW602N
Packing Ring	Asbestos Free
Gland (28-54 only)	Brass BS EN 12164 CW614N
Packing Nut	Brass BS EN 12164 CW614N
Handwheel	Aluminium
Identification Plate	Aluminium
Handwheel Nut	Brass BS EN 12164 CW614N
Compression Olive	Brass BS EN 12449:1999 CW505L OR CW507L
Compression Nut	Brass BS EN 12165 CW617N

Dimensions & Weights

SIZE (mm)	WEIGHT (kg)	A (mm)	B (mm)	C (mm)	D (mm)
15	0.34	69	74	53	26.5
22	0.50	75	86	59	23.5
28	0.70	86	105	65	25.5
35	0.95	100	110	70	30.5
42	1.45	111	131	78	34.5
54	2.50	133	152	93	37

Dimensional Drawing

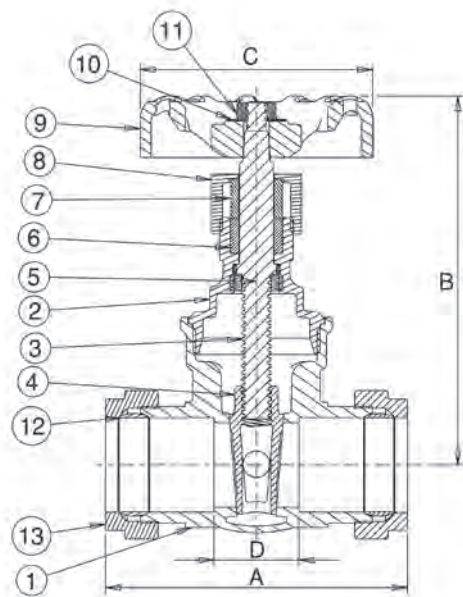

Pressure/Temperature Ratings

TEMPERATURE (°C)	-10 to 30	40	50	65	
PRESSURE (BAR)	16.0	14.3	12.6	10.0	
TEMPERATURE (°C)	80	90	100	110	120
PRESSURE (BAR)	8.7	7.8	6.9	6.0	5.0

Intermediate pressure ratings shall be determined by interpolation.

WRAS approved -10 to 99°c

PRESSURE RATING: PN16

UK END CONNECTION: Compression ends to BS EN 1057:2006: Half hard R250

OPERATOR: Handwheel.

Gate valves are best for services that require infrequent valve operation, and where the disc is kept either fully opened or fully closed. They are not practical for throttling.

SPECIFICATION: Valves are manufactured in accordance with BS EN 12288: 2010 (formerly BS 5154) PN16 for Series B ratings, but are limited to the pressure/temperature ratings detailed in BS EN 1057: 2006 for compression end fittings.

This valve is to be used on Group 2 liquids only, as defined by the Pressure Equipment Directive 2014/68/EU.*

* See page 155 for more information

Every effort has been made to ensure that the information contained in this publication is accurate at the time of publishing. Crane Ltd assumes no responsibility or liability for typographical errors or omissions or for any misinterpretation of the information within the publication and reserves the right to change without notice.

D156

Brass Gate Valve

PN16

D156



GENERAL VALVES

Features & Benefits

- Crane gate valves offer the ultimate in dependable service wherever minimum pressure drop is important

Materials

PART	MATERIAL	SIZES
Body	Brass BS EN 12164 CW617N	All
Bonnet	Brass BS EN 12164 CW617N	All
Stem	Brass BS EN 12165 CW617N	All
Packing Nut	Brass BS EN 12165 CW617N	All
Packing	Asbestos Free	All
Stem Bush	Brass BS EN 12165 CW617N	All
Disc	Brass BS EN 12164 CW617N	All
Handwheel	Aluminium	All
Handwheel Nut	Steel (Zinc Plated)	All

Dimensions & Weights

SIZE (inch)	WEIGHT (kg)	A (mm)	B (mm)	C (mm)
1/4	0.2	41	69	44
3/8	0.2	41	69	44
1/2	0.22	48	69	44
3/4	0.35	54	79	52
1	0.52	62	92	52
1 1/4	0.77	68	108	65
1 1/2	1.02	72	125	70
2	1.75	82	150	92
2 1/2	2.77	97	176	103
3	3.9	111	204	120
4	6.35	131	262	152

Dimensional Drawing

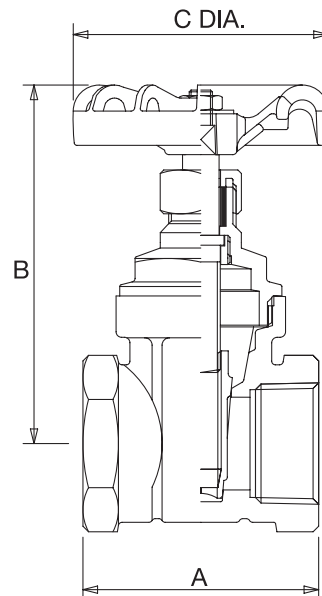

Pressure/Temperature Ratings

TEMPERATURE (°C)	-10 to 100	170
PRESSURE (BAR)	16	7

Intermediate pressure ratings shall be determined by interpolation.

PRESSURE RATING: PN16

TEMPERATURE OPERATING RANGE: -10 to 170°C

UK END CONNECTION: Taper threaded to BS EN 10226-2 (ISO 7-1) formerly BS 21

US END CONNECTION: ANSI B1.20.1

OPERATOR: Handwheel.

Gate valves are best for services that require infrequent valve operation, and where the disc is kept either fully opened or fully closed. They are not practical for throttling.

SPECIFICATION: Valves 1/4" to 2" are manufactured in accordance with BS EN 12288: 2010 PN16 for Series B ratings. Non-Rising Stem.

This valve is not suitable for use on Group 1 gases or unstable fluids, as defined by the Pressure Equipment Directive 2014/68/EU.*

* See page 155 for more information

D159

Bronze Gate Valve

PN32

D159

Features & Benefits

The D159 bronze gate valve offers a dependable and long service life across a wide variety of applications by virtue of its design and material composition.

- Non-rising stem design to minimise installation height
- Full bore design to ensure minimal pressure drop
- Adjustable gland packing for ease of maintenance
- Material selection results in superior dezincification (DZR) and corrosion resistance properties
- Body, bonnet and disc are made from low lead content bronze, typically 4-6%



Please note: the photograph & dimensional drawing denotes sizes 1/2" - 2" only.

Materials

PART	MATERIAL	SPECIFICATION	SIZES
Body	Bronze	BS EN 1982 (CC491K)	ALL
Bonnet	Bronze	BS EN 1982 (CC491K)	ALL
Stem	DZR Brass	BS EN 12164 CW602N	ALL
Disc	Bronze	BS EN 1982 (CC491K)	ALL
Stem Retainer	DZR Brass	BS EN 12164 CW602N	1/2 - 2
Stuffing Box	DZR Brass	BS EN 12164 CW602N	1/4 - 3/8, 2 1/2 - 3
Packing Ring	PTFE	-	ALL
Packing Nut	Brass	BS EN 12164 CW614N	ALL
Packing Gland	Brass	BS EN 12164 CW614N	1/4, 3/8, 1/2, 1 - 3
Handwheel	Aluminium	-	ALL
Identification Plate	Aluminium	-	ALL
Handwheel Nut	Brass	BS EN 12164 CW614N	ALL
Gasket	Asbestos Free	-	3

Dimensional Drawing

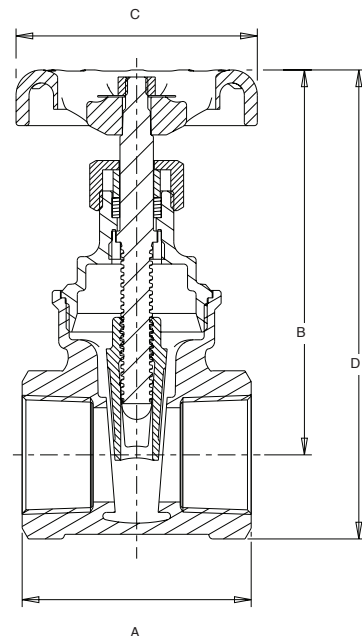

Dimensions & Weights

SIZE (inch)	A (mm)	B (mm)	C (mm)	D (mm)	WEIGHT (kg)	KV
1/4	46	75	45	86.7	0.36	-
3/8	46	75	45	86.7	0.36	-
1/2	50	78	52.3	93	0.27	21
3/4	54	84	60	103	0.38	39
1	62	105	65	127	0.59	66
1 1/4	71	111	70	139	0.84	116
1 1/2	77.5	130	78	163	1.31	162
2	87.5	153	92	193	2.09	281
2 1/2	105	232	103	283.2	5.62	411
3	111	264	121	323.3	7.89	635

Pressure/Temperature Ratings

TEMPERATURE (°C)	-10 to 100	198
PRESSURE (BAR)	32	14

Intermediate pressure ratings shall be determined by interpolation.

PRESSURE RATING: PN32
TEMPERATURE OPERATING RANGE: -10 to 198°C

UK END CONNECTION: FIG. D159: Taper threaded to BS EN 10226-2 (ISO 7-1) formerly BS 21

US END CONNECTION: FIG. D159.AT: ANSI B1.20.1

OPERATOR: Handwheel.

Gate valves are best for services that require infrequent valve operation, and where the disc is kept either fully opened or fully closed. They are not practical for throttling.

SPECIFICATION: The valve body, bonnet and disc shall be of Bronze to BS EN 1982 CC491K. The stem shall be of DZR Brass to BS EN 12164 CW602N. Operation shall be by hand wheel. Ends to be threaded to BS EN 10226-2. The valve is to be rated at PN32 and manufactured in accordance with BS EN 12288: 2010.

The Non-Rising Stem Gate Valves are unsuitable for use on Group 1 gases or unstable fluids, as defined by the Pressure Equipment Directive 2014/68/EU.

Every effort has been made to ensure that the information contained in this publication is accurate at the time of publishing. Crane Ltd assumes no responsibility or liability for typographical errors or omissions or for any misinterpretation of the information within the publication and reserves the right to change without notice.

D160

Bronze Gate Valve

Class 100

Features & Benefits

- Crane gate valves offer the ultimate in dependable service wherever minimum pressure drop is important

Materials

PART	MATERIAL	SIZES
Body	Bronze BS EN 1982 CC491K	-
Bonnet	Bronze BS EN 1982 CC491K	-
Disc	Bronze BS EN 1982 CC491K	-
Stem	Bronze BS EN 12164 CW602N	-
Packing	Asbestos Free	-
Gland	Brass BS EN 12164 CW614N	-
Packing Nut	Brass BS EN 12164 CW614N	-
Stuffing Box	Bronze BS EN 12164 CW602N	-
Handwheel	Aluminium	-
Handwheel Nut	Brass BS EN 12164 CW614N	-
Identity Plate	Aluminium	-
Gasket*	Asbestos Free	3" only

Dimensions & Weights

SIZE (inch)	WEIGHT (kg)	A (mm)	B (mm)	C (mm)	D (mm)	E (mm)
3/4	2.01	83	107	52	102	6.4
1	2.49	89	124	65	114	7.9
1 1/4	2.86	102	145	70	121	7.9
1 1/2	4.10	114	165	78	133	9.5
2	5.54	127	189	92	152	9.5
2 1/2	8.39	140	232	103	165	11.1
3	11.6	152	269	121	184	12.7

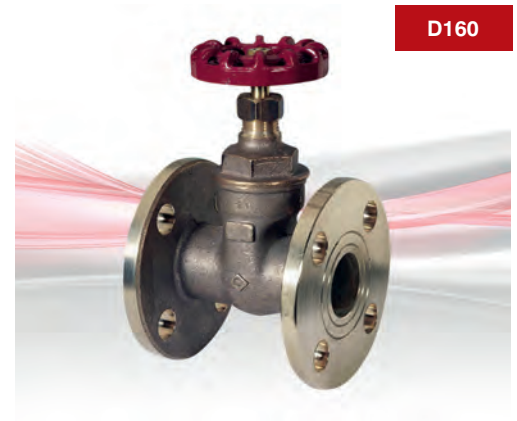
**D160**

GENERAL VALVES

Dimensional Drawing

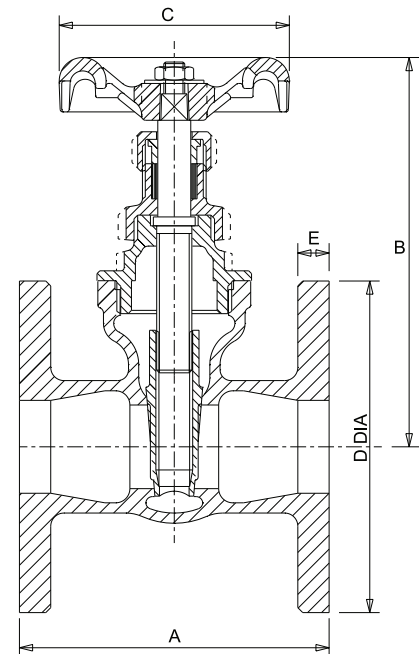
**PRESSURE RATING:** Class 100**TEMPERATURE OPERATING RANGE:** -10 to 170°C**UK END CONNECTION:** BS 10 Table E**OPERATOR:** Handwheel.

Gate valves are best for services that require infrequent valve operation, and where the disc is kept either fully opened or fully closed. They are not practical for throttling.

SPECIFICATION: Solid wedge disc, Non-rising stem, screwed-in bonnet. Valves are manufactured in accordance with BS 1952 Class 100 for series B ratings. End flanges conform to BS 10 Table E with flat face and are normally supplied drilled. This valve is not suitable for use on Group 1 gases or unstable fluids, as defined by the Pressure Equipment Directive 97/23/E.*

AVAILABLE OPTIONS: Flanges undrilled

* See page 155 for more information

Every effort has been made to ensure that the information contained in this publication is accurate at the time of publishing. Crane Ltd assumes no responsibility or liability for typographical errors or omissions or for any misinterpretation of the information within the publication and reserves the right to change without notice.

Valid as of 290719

DM160

Bronze Gate Valve

PN16 - Series B

DM160

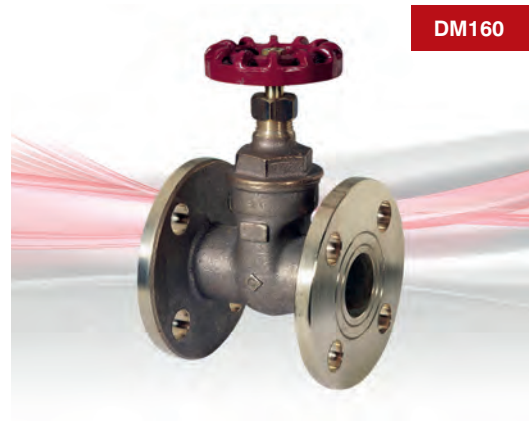

Features & Benefits

- Crane gate valves offer the ultimate in dependable service wherever minimum pressure drop is important

Materials

PART	MATERIAL	SIZES
Body	Bronze BS EN 1982 CC491K	All
Bonnet	Bronze BS EN 1982 CC491K	All
Disc	Bronze BS EN 1982 CC491K	All
Stem	Bronze BS EN 1982 CC491K	2 1/2 & 3
Stem	DZR Brass BS EN 12164 CW602N	3/4 - 2
Packing	Asbestos Free	All
Gland	Brass BS EN 12164 CW614N	All
Packing Nut	Brass BS EN 12164 CW614N	All
Stuffing Box	DZR Brass BS EN 12164 CW602N	1 1/4 & 1 1/2
Stuffing Box	Brass BS EN 12164 CW614N	2" only
Stuffing Box	Bronze BS EN 1982 CC491K	2 1/2 & 3
Stem Bush	Aluminium Bronze BS EN 12163 CW301G	3/4 & 1
Handwheel	Malleable Iron BS EN 1562 GJMB-300-6	3" only
Handwheel	Aluminium	3/4 - 2 1/2
Handwheel Nut	Brass BS EN 12164 CW614N	All
ID Plate	Aluminium	All
Gasket	Asbestos Free	3" only

Dimensional Drawing

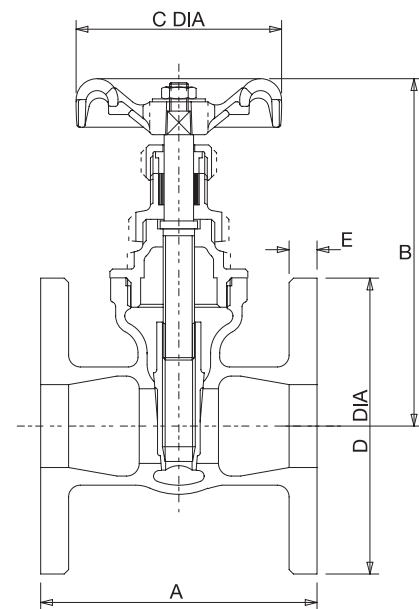

Dimensions & Weights

SIZE (mm)	WEIGHT (kg)	A (mm)	B (mm)	C (mm)	D (mm)	E (mm)
20	1.57	89	105	65	105	6
25	2.5	99	116	70	115	8
32	3.38	110	141	92	140	8
40	4.93	120	168	92	150	9
50	5.54	135	189	103	165	11
65	8.39	165	232	103	185	13
80	12.25	185	264	121	200	13

Pressure/Temperature Ratings

TEMPERATURE (°C)	-10 to 100	170
PRESSURE (BAR)	16	7

Intermediate pressure ratings shall be determined by interpolation.

PRESSURE RATING: PN16

TEMPERATURE OPERATING RANGE: -10 to 170°C

END CONNECTION: Flanged BS EN 1092-3 (formerly BS 4504)

OPERATOR: Handwheel.

Gate valves are best for services that require infrequent valve operation, and where the disc is kept either fully opened or fully closed. They are not practical for throttling.

SPECIFICATION: Valves are manufactured in accordance with BS 5154: 1991 PN16 for Series B ratings, having 'short' face-to-face dimensions.

Non-Rising Stem. End flanges conform to BS EN 1092-3 with flat face and are normally supplied drilled.

This valve is not suitable for use on Group 1 gases or unstable fluids, as defined by the Pressure Equipment Directive 2014/68/EU.*

AVAILABLE OPTIONS: Flanges Undrilled, P150 Locking Device

* See page 155 for more information

D161

Bronze Gate Valve

PN25

D161

GENERAL VALVES



Features & Benefits

- Crane gate valves offer the ultimate in dependable service wherever minimum pressure drop is important

Materials

NO.	PART	MATERIAL	SIZES
1	Body	Bronze BS EN 1982 CC491K	-
2	Bonnet	Bronze BS EN 1982 CC491K	-
3	Disc	Bronze BS EN 1982 CC491K	-
4	Stem	Bronze BS EN 12164 CW602N	-
5	Packing	Asbestos Free	-
6	Gland	Brass BS EN 12164 CW614N	-
7	Packing Nut	Brass BS EN 12164 CW614N	-
8	Stuffing Box	Bronze BS EN 12164 CW602N	-
9	Handwheel	Aluminium	-
10	Handwheel Nut	Brass BS EN 12164 CW614N	-
11	Identity Plate	Aluminium	-
12	Gasket*	Asbestos Free	3" only

Dimensional Drawing

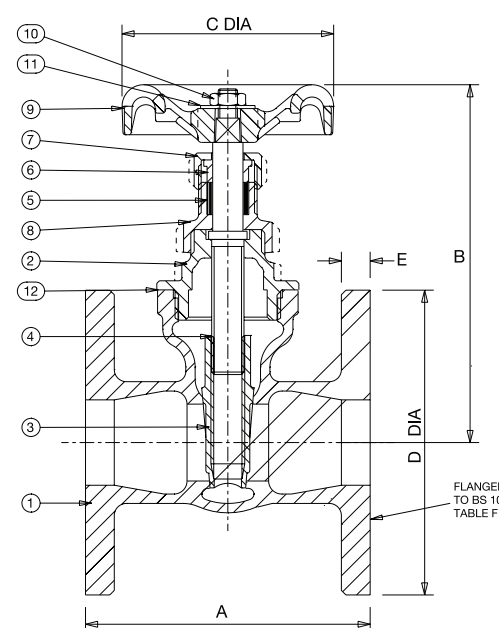

Dimensions & Weights

SIZE (inch)	WEIGHT (kg)	A (mm)	B (mm)	C (mm)	D (mm)	E (mm)
3/4	2.23	83	107	52	102	7.9
1	2.97	95	124	65	121	9.5
1 1/4	3.54	108	145	70	133	9.5
1 1/2	4.65	121	165	78	140	11.1
2	6.44	133	189	92	165	11.1
2 1/2	10.4	152	232	103	184	12.7
3	13.6	171	269	121	203	14.3

PRESSURE RATING: PN25**TEMPERATURE OPERATING RANGE:** -10 to 100°C**END CONNECTION:** Flanged to BS 10 Table F**SPECIFICATION:** End flanges conform to BS 10 Table F with flat faces and are normally supplied drilled.

DM161

Bronze Gate Valve

PN25

DM161



Features & Benefits

- Crane gate valves offer the ultimate in dependable service wherever minimum pressure drop is important

Materials

NO.	PART	MATERIAL	SIZES
1	Body	Bronze BS EN 1982 CC491K	All
2	Bonnet	Bronze BS EN 1982 CC491K	All
3	Disc	Bronze BS EN 1982 CC491K	All
4	Stem	Bronze BS EN 1982 CC491K	2 1/2 & 3
4	Stem	DZR Brass BS EN 12164 CW602N	3/4 - 2
5	Packing	Asbestos Free	All
6	Gland	Brass BS EN 12164 CW614N	All
7	Packing Nut	Brass BS EN 12164 CW614N	All
8	Stuffing Box	DZR Brass BS EN 12164 CW602N	1 1/4 & 1 1/2
8	Stuffing Box	Brass BS EN 12164 CW614N	2" only
8	Stuffing Box	Bronze BS EN 1982 CC491K	2 1/2 & 3
8	Stem Bush	Al. Bronze NES 834 Pt.2	3/4 & 1
9	Handwheel	Malleable Iron BS EN 1562 GJMB-300-6	3" only
9	Handwheel	Aluminium	3/4 - 2 1/2
10	Handwheel Nut	Brass BS EN 12164 CW614N	All
11	ID Plate	Aluminium	All
12	Gasket	Asbestos Free	3" only

Dimensional Drawing

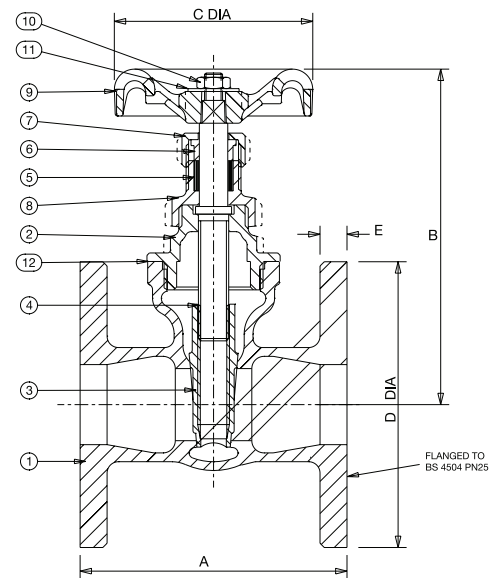

Dimensions & Weights

SIZE (mm)	WEIGHT (kg)	A (mm)	B (mm)	C (mm)	D (mm)	E (mm)
20	1.73	90	105	52	105	8
25	2.5	100	116	65	115	9
32	4.33	110	145	70	140	9
40	5.75	120	165	78	150	11
50	7.5	135	189	92	165	11
65	10.8	165	232	103	185	13
80	14.4	185	264	121	200	14

PRESSURE RATING: PN25

TEMPERATURE OPERATING RANGE: -10 to 186°C

UK END CONNECTION: Flanged BS 4504

US END CONNECTION: Not Specified

OPERATOR: Handwheel.

Gate valves are best for services that require infrequent valve operation, and where the disc is kept either fully opened or fully closed. They are not practical for throttling.

SPECIFICATION: Valves are manufactured in accordance with BS 5154 PN25 for Series B ratings, having 'short' face-to-face dimensions. Non-Rising Stem. End flanges conform to BS 4504 Section 3.3 with flat face and are normally supplied drilled. Note: Users' attention is drawn to BS 4504 Section 3.3, Clause 8 regarding types of gaskets and mating flanges to be used with metric flanged valves.

This valve is not suitable for use on group 1 gases or unstable fluids, as defined by the Pressure Equipment Directive 2014/68/EU.*

AVAILABLE OPTIONS: Flanges Undrilled

* See page 155 for more information

Valid as of 120220

Every effort has been made to ensure that the information contained in this publication is accurate at the time of publishing. Crane Ltd assumes no responsibility or liability for typographical errors or omissions or for any misinterpretation of the information within the publication and reserves the right to change without notice.

D162

Bronze Gate Valve

ANSI Class 150

D162

GENERAL VALVES



Features & Benefits

- Crane gate valves offer the ultimate in dependable service wherever minimum pressure drop is important

Materials

NO.	PART	MATERIAL	SIZES
1	Body	Bronze BS EN 1982 CC491K	-
2	Bonnet	Bronze BS EN 1982 CC491K	-
3	Disc	Bronze BS EN 1982 CC491K	-
4	Stem	Bronze BS EN 1982 CC491K	2 1/2 & 3
4	Stem	DZR Brass BS EN 12164 CW602N	3/4 - 2
5	Packing	Asbestos Free	-
6	Gland	Brass BS EN 12164 CW614N	-
7	Packing Nut	Brass BS EN 12164 CW614N	-
8	Stuffing Box	DZR Brass BS EN 12164 CW602N	1 1/4 & 1 1/2
8	Stuffing Box	Brass BS EN 12164 CW614N	2" only
8	Stuffing Box	Bronze BS EN 1982 CC491K	2 1/2 & 3
8	Stem Bush	Al Bronze BS EN 12163 CW301G	3/4 & 1
9	Handwheel	MI BS EN 1562 GJMB-300-6	3" only
9	Handwheel	Aluminium	3/4 - 2 1/2
10	Handwheel Nut	Brass BS EN 12164 CW614N	-
11	Identity Plate	Aluminium	-
12	Gasket*	Asbestos Free	3" only

Dimensional Drawing

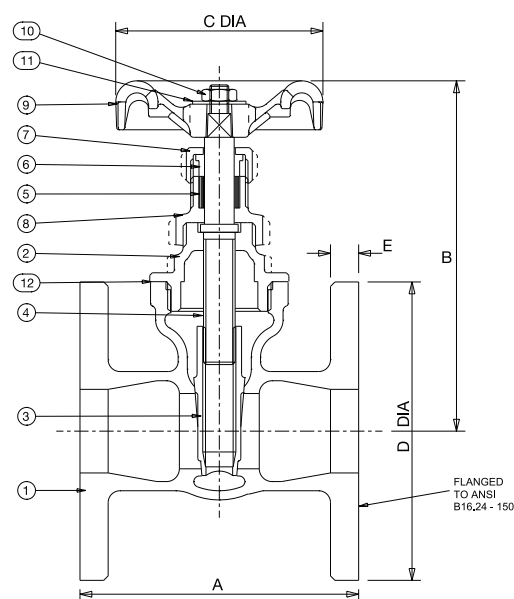

Dimensions & Weights

SIZE (inch)	WEIGHT (kg)	A (mm)	B (mm)	C (mm)	D (mm)	E (mm)
3/4	2.27	89	107	52	98.4	8.7
1	2.59	99	124	65	108	9.5
1 1/4	2.86	110	145	70	117.5	10.3
1 1/2	4.10	120	165	78	127	11.1
2	5.54	135	189	92	152.4	12.7
2 1/2	8.39	165	232	103	177.8	14.3
3	11.6	185	269	121	190.5	15.9

PRESSURE RATING: ANSI Class 150
TEMPERATURE OPERATING RANGE: -10 to 186°C
END CONNECTION: ANSI B16.24 Class 150

SPECIFICATION: Bronze Gate Valve, Non Rising Stem, Handwheel Operated, Solid Wedge Disc

Valid as of 290719

Every effort has been made to ensure that the information contained in this publication is accurate at the time of publishing. Crane Ltd assumes no responsibility or liability for typographical errors or omissions or for any misinterpretation of the information within the publication and reserves the right to change without notice.

D166

Bronze Gate Valve

PN32

D166



Features & Benefits

- Crane gate valves offer the ultimate in dependable service wherever minimum pressure drop is important

Materials

PART	MATERIAL	SIZES
Body	Bronze BS EN 1982 CC491K	All
Bonnet	Bronze BS EN 1982 CC491K	All
Stem	Bronze BS EN 1982 CC491K	1/4 - 2
Stem	Bronze BS EN 1982 CC491K	All
Disc	Bronze BS EN 1982 CC491K	All
Packing	Asbestos Free	All
Gland	Brass BS EN 12164 CW614N	All
Packing Nut	Brass BS EN 12164 CW614N	1/4 - 2
Packing Nut	Bronze BS EN 1982 CC491K	2 1/2 & 3
Handwheel	Aluminium	All
ID Plate	Aluminium	All
Handwheel Nut	Brass BS EN 12164 CW614N	All

Dimensional Drawing

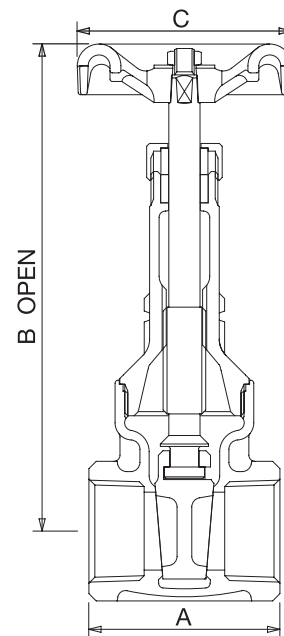

Dimensions & Weights

SIZE (inch)	WEIGHT (kg)	A (mm)	B (mm)	C (mm)
1/4	0.32	46	126	45
3/8	0.31	46	126	45
1/2	0.46	51	129	52
3/4	0.72	55	159	65
1	1.1	63	189	70
1 1/4	1.5	71	219	78
1 1/2	2.25	73	246	92
2	3.2	84	301	92
2 1/2	5.8	105	369	134
3	8.52	111	416	134

Pressure/Temperature Ratings

TEMPERATURE (°C)	-10 to 100	198
PRESSURE (BAR)	32	14

Intermediate pressure ratings shall be determined by interpolation.

PRESSURE RATING: PN32

TEMPERATURE OPERATING RANGE:
-10 to 198°C

UK END CONNECTION: Taper threaded to BS EN 10226-2 (ISO 7-1) formerly BS 21

US END CONNECTION: ANSI B1.20.1

OPERATOR: Handwheel.

Gate valves are best for services that require infrequent valve operation, and where the disc is kept either fully opened or fully closed. They are not practical for throttling.

SPECIFICATION: Valves are manufactured in accordance with BS EN 12288: 2010 PN32 for Series B ratings. Rising Stem.

This valve is not suitable for use on Group 1 gases or unstable fluids, as defined by the Pressure Equipment Directive 2014/68/EU.*

* See page 155 for more information

D180

Bronze Gate Valve

PN32

D180

GENERAL VALVES

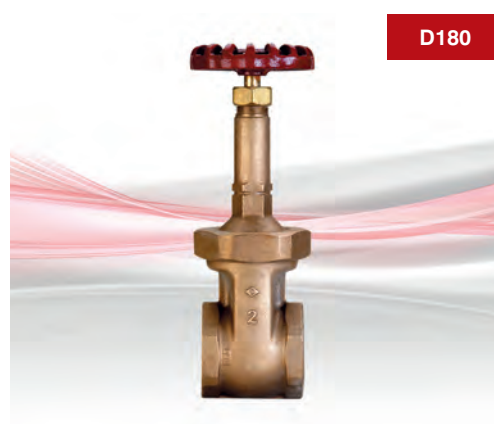

Features & Benefits

- Crane gate valves offer the ultimate in dependable service wherever minimum pressure drop is important

Materials

PART	MATERIAL	SIZES
Body	Bronze BS EN 1982 CC491K	All
Bonnet	Bronze BS EN 1982 CC491K	All
Stem	Bronze BS EN 1982 CC491K	1/4 - 2
Stem	Bronze BS EN 12164 CW602N	2 1/2 & 3
Disc	Bronze BS EN 1982 CC491K	All
Union Ring	Bronze BS EN 1982 CC491K	1/4 - 2 only
Packing	Asbestos Free	All
Gland	Brass BS EN 12164 CW614N	All
Packing Nut	Brass BS EN 12164 CW614N	1/4 - 2
Packing Nut	Bronze BS EN 1982 CC491K	2 1/2 & 3
Handwheel	Aluminium	1/4 - 2
Handwheel	Malleable Iron BS EN 1562 GJMB-300-6	2 1/2 & 3
ID Plate	Aluminium	All
Handwheel Nut	Brass BS EN 12164 CW614N	All
Stud	Steel BS 970 070M20	2 1/2 & 3" only
Stud Nut	Steel BS 4190 Gr.4	2 1/2 & 3" only
Gasket	Asbestos Free	2 1/2 & 3" only

Dimensional Drawing

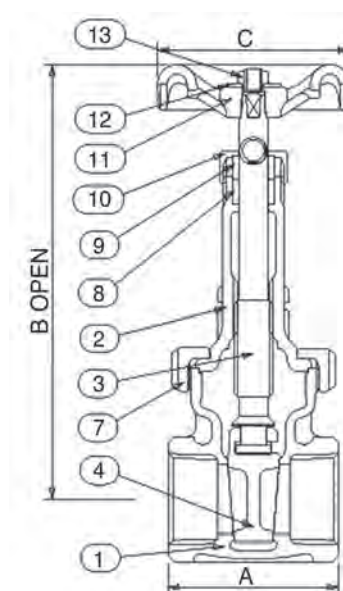

Dimensions & Weights

SIZE (inch)	WEIGHT (kg)	A (mm)	B (mm)	C (mm)
1/4	0.32	46	126	45
3/8	0.31	46	126	45
1/2	0.46	51	129	52
3/4	0.72	55	159	65
1	1.1	63	189	70
1 1/4	1.5	71	219	78
1 1/2	2.3	73	246	92
2	3.2	83	301	92
2 1/2	5.8	120	369	134
3	8.5	134	416	134

Pressure/Temperature Ratings

TEMPERATURE (°C)	-10 to 120	260
PRESSURE (BAR)	32	14

Intermediate pressure ratings shall be determined by interpolation.

PRESSURE RATING: PN32

TEMPERATURE OPERATING RANGE:
-10 to 260°C

UK END CONNECTION: Taper threaded to BS EN 10226-2 (ISO 7-1) formerly BS 21

US END CONNECTION: ANSI B1.20.1

* See page 155 for more information

OPERATOR: Handwheel.

Gate valves are best for services that require infrequent valve operation, and where the disc is kept either fully opened or fully closed. They are not practical for throttling.

SPECIFICATION: Valves are manufactured in accordance with BS EN 12288:2010 PN32 for Series A ratings. Rising Stem.

Sizes 1/4" to 2" have a union bonnet; sizes 2 1/2" and 3" have a bolted bonnet.

This valve is not suitable for use on group 1 gases or unstable fluids, as defined by the Pressure Equipment Directive 2014/68/EU.*

D235

Gate Valve

D235

PN32

Features & Benefits

The D235 bronze gate valve offers a dependable and long service life across a wide variety of applications by virtue of its design and material composition.

- Non-rising stem design to minimise installation height
- Full bore design to ensure minimal pressure drop
- Adjustable gland packing for ease of maintenance
- Material selection results in superior dezincification (DZR) and corrosion resistance properties
- Body, bonnet and disc are made from low lead content bronze, typically 4-6%



Materials - 1/2 - 2"

PART	MATERIAL	SPECIFICATION	SIZES
Body	Bronze	BS EN 1982 (CC491K)	ALL
Bonnet	Bronze	BS EN 1982 (CC491K)	ALL
Stem	DZR Brass	BS EN 12164 CW602N	ALL
Disc	Bronze	BS EN 1982 (CC491K)	ALL
Stem Retainer	DZR Brass	BS EN 12164 CW602N	ALL
Packing Ring	PTFE	-	ALL
Packing Gland	Brass	BS EN 12164 CW614N	ALL
Lockshield	Brass	BS EN 12164 CW614N	ALL
Lockshield Spanner	Mild Steel	-	ALL
Lockshield T-Bar	Mild Steel	-	ALL

Dimensional Drawing

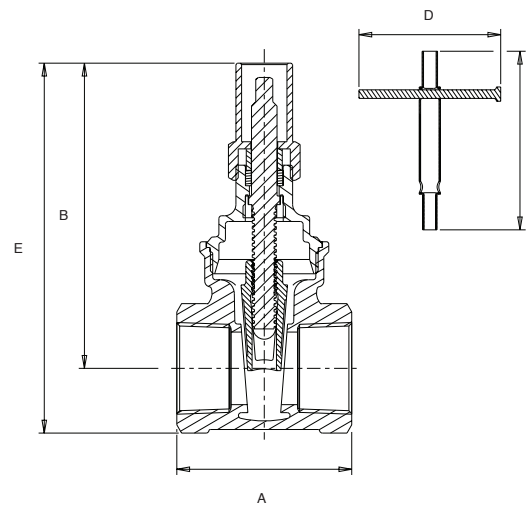

Dimensions & Weights

SIZE (inch)	A (mm)	B (mm)	C (mm)	D (mm)	E (mm)	LOCKSHIELD KEY NO.	WEIGHT (kg)	KV
1/2	50	78	90	100	93	1	0.27	21
3/4	54	87	90	100	106	1	0.38	39
1	62	106	125	100	128	1	0.59	66
1 1/4	71	116	125	100	144	2	0.89	116
1 1/2	77.5	132	125	100	165	2	1.31	162
2	87.5	156	125	100	194	2	2.09	281

Pressure/Temperature Ratings

TEMPERATURE (°C)	-10 to 100	150	198
PRESSURE (BAR)	32	22.8	14

Intermediate pressure ratings shall be determined by interpolation.

SPECIFICATION: The valve body, bonnet and disc shall be of Bronze to BS EN 1982 CC491K.

The stem shall be of DZR Brass to BS EN 12164 CW602N. Operation shall be by lockshield. Ends to be threaded to BS EN 10226-2.

The valve is to be rated at PN32 and manufactured in accordance with BS EN 12288: 2010.

The Non-Rising Stem Gate Valves are unsuitable for use on Group 1 gases or unstable fluids, as defined by the Pressure Equipment Directive 2014/68/EU.

Valid as of 290719

Every effort has been made to ensure that the information contained in this publication is accurate at the time of publishing. Crane Ltd assumes no responsibility or liability for typographical errors or omissions or for any misinterpretation of the information within the publication and reserves the right to change without notice.

D237

Bronze Gate Valve with Lockshield



PN20

D237

GENERAL VALVES



Features & Benefits

- Crane gate valves offer the ultimate in dependable service wherever minimum pressure drop is important.
- The D237 carries the British Standards Institution Kitemark - your assurance of exacting quality standards
- WRAS approved for use on wholesome (potable) water in sizes 1/2" - 2" only
- WRAS approval temperature 85°C max

Materials

PART	MATERIAL	SIZES
Body	Bronze BS EN 1982 CC491K	1/2 - 3
Bonnet	Bronze BS EN 1982 CC491K	1/2 - 3
Disc	Bronze BS EN 1982 CC491K	1/2 - 3
Stem	DZR Brass BS EN 12164 CW602N	1/2 - 3
Stuffing Box	DZR Brass BS EN 12164 CW602N	2 1/2 & 3
Stem Retainer	DZR Brass BS EN 12164 CW602N	1/2 - 2
Gland	Brass BS EN 12164 CW614N	1 - 3
Packing	Asbestos Free	1/2 - 3
Lockshield	Brass BS EN 12164 CW614N	1/2 - 3
Box Spanner	Mild Steel	1/2 - 3

Dimensional Drawing

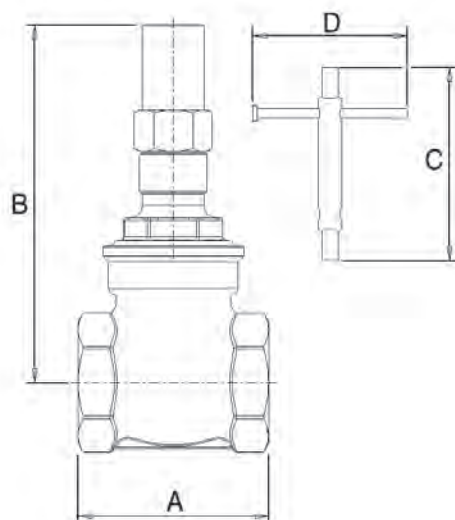

Dimensions & Weights

SIZE (inch)	WEIGHT (kg)	A (mm)	B (mm)	C (mm)	D (mm)
1/2	0.276	50	78	90	100
3/4	0.389	54	87	90	100
1	0.593	62	106	125	100
1 1/4	0.831	71	116	125	100
1 1/2	1.248	77.5	132	125	100
2	1.882	87.5	156	125	100
2 1/2	4.15	96	218	-	-
3	6.24	105	253	-	-

Pressure/Temperature Ratings

TEMPERATURE (°C)	-10 to 100	180
PRESSURE (BAR)	20	9

Intermediate pressure ratings shall be determined by interpolation.

PRESSURE RATING: PN20

TEMPERATURE OPERATING RANGE: -10 to 180°C

END CONNECTION: Taper threaded to BS EN 10226-2 (ISO 7-1) formerly BS 21

* See page 155 for more information

OPERATOR: Lockshield.

Gate valves are best for services that require infrequent valve operation, and where the disc is kept either fully opened or fully closed. They are not practical for throttling.

SPECIFICATION: Solid wedge disc, non-rising stem, screwed in bonnet. Valves are manufactured in accordance with BS EN 12288: 2010 PN20 Series B and are BSI Kitemark approved.

This valve is not suitable for use on group 1 gases or unstable fluids, as defined by the Pressure Equipment Directive 2014/68/EU.*

AVAILABLE OPTIONS: P103 lockshield key 1/2" - 2" P100 lockshield key 2 1/2" - 3"

D237A

Lockshield Operated DZR Gate Valve

PN20

D237A



Features & Benefits

- Crane gate valves offer the ultimate in dependable service wherever minimum pressure drop is important

Materials

PART	MATERIAL	SIZES
Body	DZR Brass BS EN 12165 CW602N	All
Bonnet	DZR Brass BS EN 12165 CW602N	All
Stem	DZR Brass BS EN 12164 CW602N	All
Lockshield	Brass BS EN 12165 CW614N	All
Packing	Asbestos Free	All
Stem Bush	DZR Brass BS EN 12164 CW602N	All
Disc	DZR Brass BS EN 12165 CW602N	All

Dimensional Drawing

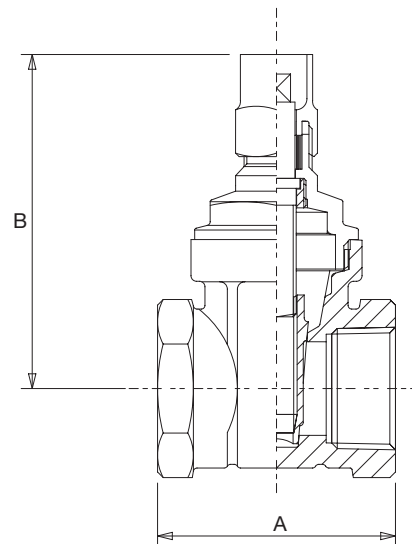

Dimensions & Weights

SIZE (inch)	WEIGHT (kg)	A (mm)	B (mm)
1/2	0.23	50	65
3/4	0.36	54	75
1	0.5	62	81
1 1/4	0.82	70	105
1 1/2	1.08	72	122
2	1.83	88	149

Pressure/Temperature Ratings

TEMPERATURE (°C)	-10 to 100	180
PRESSURE (BAR)	20	9

Intermediate pressure ratings shall be determined by interpolation.

PRESSURE RATING: PN20
TEMPERATURE OPERATING RANGE:

-10 to 180°C

UK END CONNECTION:

Taper threaded to BS EN 10226-2 (ISO 7-1) formerly BS 21

OPERATOR: Lockshield.

Gate valves are best for services that require infrequent valve operation, and where the disc is kept either fully opened or fully closed. They are not practical for throttling.

SPECIFICATION: Valves are manufactured in accordance with BS EN 12288: 2010 for Series B ratings. Non-Rising Stem.

This valve is not suitable for use on group 1 gases or unstable fluids, as defined by the Pressure Equipment Directive 2014/68/EU.*

AVAILABLE OPTIONS: P103 Lockshield Key

* See page 155 for more information

Valid as of 290719

Every effort has been made to ensure that the information contained in this publication is accurate at the time of publishing. Crane Ltd assumes no responsibility or liability for typographical errors or omissions or for any misinterpretation of the information within the publication and reserves the right to change without notice.

D255C

Gate Valve



PN16

D255C

GENERAL VALVES

Features & Benefits

- Robust and high quality bronze body with integral seating surfaces
- Offers the ultimate in dependable service wherever minimum pressure drop is important
- WRAS approved for use with wholesome (potable) water
- Inside screw pattern with non-rising stem



Materials

PART	MATERIAL
Body	Bronze BS EN 1982 CC491K
Bonnet	Bronze BS EN 1982 CC491K
Stem	DZR Brass BS EN 12164 CW602N
Disc	Bronze BS EN 1982 CC491K
Stem Retainer	DZR Brass BS EN 12164 CW602N
Packing Ring	Asbestos Free
Gland (28-54 only)	Brass BS EN 12164 CW614N
Lockshield	Brass BS EN 12164 CW614N
Compression Olive	Brass BS EN 12449:1999 CW505L OR CW507L
Compression Nut	Brass BS EN 12165 CW617N

Dimensional Drawing

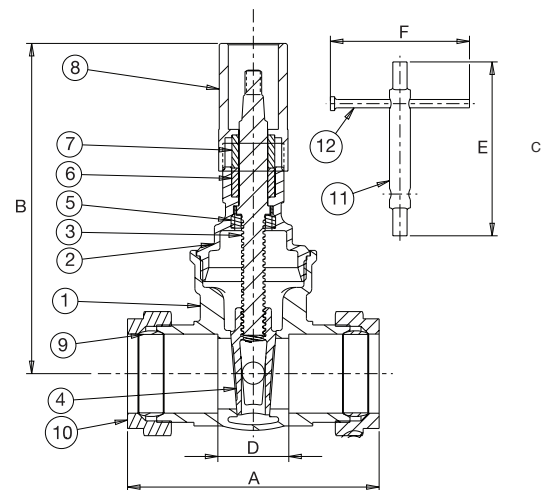

Dimensions & Weights

SIZE (mm)	WEIGHT (kg)	A (mm)	B (mm)	D (mm)
15	0.34	69	78	26.5
22	0.50	75	90	23.5
28	0.70	86	110	25.5
35	0.95	100	115	30.5
42	1.45	111	136	34.5
54	2.50	133	160	37

Pressure/Temperature Ratings

TEMPERATURE (°C)	-10 to 30	40	50	65	
PRESSURE (BAR)	16.0	14.3	12.6	10.0	
TEMPERATURE (°C)	80	90	100	110	120
PRESSURE (BAR)	8.7	7.8	6.9	6.0	5.0

Intermediate pressure ratings shall be determined by interpolation.

WRAS approved -10 to 99 °C

PRESSURE RATING: PN16

UK END CONNECTION:

Compression ends to
BS EN 1057:2006: Half hard R250

OPERATING INSTRUCTIONS: Lockshield.

Gate valves are best for services that require infrequent valve operation, and where the disc is kept either fully opened or fully closed. They are not practical for throttling.

SPECIFICATION: Valves are manufactured in accordance with BS EN 12288: 2010 (formerly BS 5154) PN16 for Series B ratings, but are limited to the pressure/ temperature ratings detailed in BS EN 1057: 2006 for compression end fittings.

This valve is to be used on Group 2 liquids only, as defined by the Pressure Equipment Directive 2014/68/EU.*

AVAILABLE OPTIONS: P100 and P102 Lockshield Keys

* See page 155 for more information

F52

Gate Valve

Class 100

F52

Features & Benefits

- Crane gate valves offer the ultimate in dependable service wherever minimum pressure drop is important

Materials

NO.	PART	MATERIAL	SIZES
1	Body	Cast Iron BS EN 1561 GJL-250	All
2	Bonnet	Cast Iron BS EN 1561 GJL-250	All
3	Bonnet Gasket	Asbestos Free	All
4	Bonnet Bolts	Steel BS 4190 Gr. 8.8	All
5	Bonnet Nuts	Steel BS 4190 Gr. 8.0	All
6	Disc	Cast Iron BS EN 1561 GJL-250	All
7	Stem	Brass BS EN 12164 CW721R	All
8	Stuffing Box	Cast Iron BS EN 1561 GJL-250	All
9	Gland	Cast Iron BS EN 1561 GJL-250	All
10	Gland Bolts	Steel BS 4190 Gr. 8.8	8 - 12
11	Gland Studs	Steel BS 4439 Gr. 8.8	2 - 6
12	Stuffing Box Gasket	Asbestos Free	All
13	Packing	Asbestos Free	All
14	Handwheel	Duct Iron BS EN 1563 GJS-450-10	All
15	Body Seat Ring	Bronze BS EN 1982 CC491K	All
16	Disc Stem Nut	Bronze BS EN 1982 CC491K	All
17	Disc Ring	Bronze BS EN 1982 CC491K	All
18	Handwheel Nut	Steel BS 4190 Gr. 8.0	All
19	Gland Stud/Bolt Nuts	Steel BS 4190 Gr. 8.0	All



Dimensional Drawing

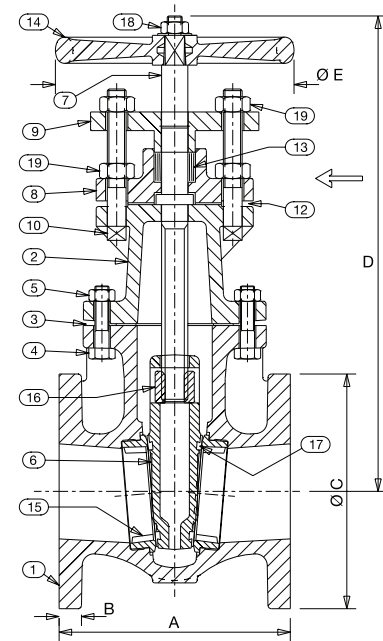

VIEW FROM ARROW
SIZES 2" TO 6"

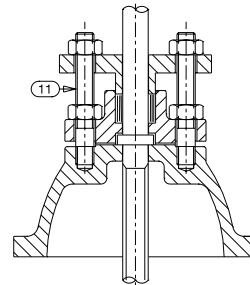

Dimensions & Weights

SIZE (inch)	WEIGHT (kg)	A (mm)	B (mm)	ØC (mm)	D (mm)	ØE (mm)
2	30.0	5.75	0.75	6.0	11.1	5.5
2 1/2	35.1	6.25	0.75	6.5	11.9	5.5
3	44.1	6.5	0.75	7.25	13.5	6.0
4	60.0	6.75	0.88	8.5	14.8	8.0
5	86.0	7.5	0.88	10.0	17.2	9.0
6	98.1	8.25	0.88	11.0	18.8	9.0
8	178.0	9.5	1.0	13.25	24.0	12.0
10	271.0	10.75	1.0	16.0	28.9	14.0
12	384.0	12.0	1.0	18.0	33.3	16.0

SIZE (mm)	WEIGHT (kg)	A (mm)	B (mm)	ØC (mm)	D (mm)	ØE (mm)
50	13.6	146.1	19.1	152.0	281.6	139.7
65	15.9	158.8	19.1	165.1	301.7	139.7
80	20.0	165.1	19.1	184.0	343.0	152.4
100	27.2	171.5	22.2	215.9	374.7	203.2
125	39.0	190.5	22.2	254.0	436.8	228.6
150	44.5	209.6	22.2	279.4	478.2	228.6
200	81.6	241.3	25.4	337.0	609.1	304.8
250	122.9	273.1	25.4	406.0	732.9	355.6
300	174.2	304.8	28.6	457.2	844.6	406.4

PRESSURE RATING: Class 100

TEMPERATURE OPERATING RANGE: -10 to 170°C

UK END CONNECTION: BS10 Table D or E

OPERATING INSTRUCTIONS: Handwheel.

Gate valves are best for services that require infrequent valve operation, and where the disc is kept either fully opened or fully closed. They are not practical for throttling.

SPECIFICATION: End flanges conform to BS 10 Table D or E with flat face and are normally supplied drilled. Orders must specify whether Table D or Table E flanges are required. Wedge disc, non-rising stem, inside screw, all iron. Each valve is hydrostatically tested to BS 6755 Pt 1.

This valve is not suitable for use on group 1 gases or unstable fluids, as defined by the Pressure Equipment Directive 2014/68/EU.*

AVAILABLE OPTIONS: P150 Locking Device

* See page 155 for more information

Every effort has been made to ensure that the information contained in this publication is accurate at the time of publishing. Crane Ltd assumes no responsibility or liability for typographical errors or omissions or for any misinterpretation of the information within the publication and reserves the right to change without notice.

Valid as of 290719

F53

Cast Iron Gate Valve

Class 125

F53

GENERAL VALVES

Features & Benefits

- Crane cast iron gate valves offer the ultimate in dependable service wherever minimum pressure drop is important

Materials

PART	MATERIAL	SIZES
Body	Cast Iron BS EN 1561 GJL-250	All
Bonnet	Cast Iron BS EN 1561 GJL-250	All
Bonnet Gasket	Asbestos Free	All
Disc	Cast Iron BS EN 1561 GJL-250	All
Stem	Brass BS EN 12164 CW721R	All
Stuffing Box	Cast Iron BS EN 1561 GJL-250	All
Gland	Cast Iron BS EN 1561 GJL-250	All
Stuffing Box Gasket	Asbestos Free	All
Packing	Asbestos Free	All
Handwheel	Cast Iron	All
Body Seat Ring	Bronze BS EN 1982 CC491K	All
Disc Stem Nut	Bronze BS EN 1982 CC491K	All
Disc Ring	Bronze BS EN 1982 CC491K	All



Dimensional Drawing

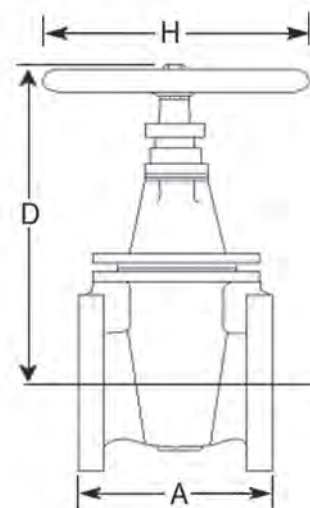

Dimensions & Weights

SIZE (inch)	WEIGHT (kg)	A (mm)	D (mm)	H (mm)
2	12.7	178	277	140
2 ¹ / ₂	15.8	190	296	140
3	19.5	203	337	152
4	29.3	229	369	203
5	39.5	254	429	229
6	45.8	267	470	229
8	84	292	600	305
10	148	330	722	356
12	198	356	818	406

Pressure/Temperature Ratings

TEMPERATURE (°C)	-10 to 65	230
PRESSURE (BAR)	13.8	8.6

Intermediate pressure ratings shall be determined by interpolation.

PRESSURE RATING: Class 125

TEMPERATURE OPERATING RANGE: -10 to 230°C

US END CONNECTION: ANSI Class 125

OPERATOR: Handwheel.

Gate valves are best for services that require infrequent valve operation, and where the disc is kept either fully opened or fully closed. They are not practical for throttling.

SPECIFICATION: Valves are manufactured in accordance with BS 5150:1990. End flanges conform to BS 1560 Section 3.2/ANSI B16.1 Class 125 with flat face and are normally supplied drilled.

Wedge Disc, Non-Rising Stem, Inside Screw, Bronze Trim. This valve is not suitable for use on group 1 gases or unstable fluids, as defined by the Pressure Equipment Directive 2014/68/EU.*

AVAILABLE OPTIONS: Flanges Undrilled

* See page 155 for more information

F54

Gate Valve

Class 100

F54



Features & Benefits

- Offer the ultimate in dependable service wherever minimum pressure drop is important

Materials

NO.	PART	MATERIAL	SIZES
1	Body	Cast Iron BS EN 1561 GJL-250	All
2	Bonnet	Cast Iron BS EN 1561 GJL-250	All
3	Bonnet Gasket	Asbestos Free	All
4	Bonnet Bolts	Steel BS4190 Gr.8.8	All
5	Bonnet Nuts	Steel BS4190 Gr.8.0	All
6	Disc	Cast Iron BS EN 1561 GJL-250	All
7	Stem	Steel SUS410	All
8	Stuffing Box	Cast Iron BS EN 1561 GJL-250	All
9	Gland	Cast Iron BS EN 1561 GJL-250	All
10	Gland Bolts	Steel BS 4190 Gr.8.8	8 - 12
11	Gland Studs	Steel BS 4439 Gr.8.8	2 - 6
12	Stuffing Box Gasket	Asbestos Free	All
13	Packing	Asbestos Free	All
14	Handwheel	Ductile Iron BS EN 1563 GJS-450-10	All
15	Body Seat Ring	Cast Iron BS EN 1561 GJL-250	All
16	Disc Stem Nut	Ductile Iron BS EN 1563 GJS-450-10	All
17	Disc Ring	Cast Iron BS EN 1561 GJL-250	All
18	Handwheel Nut	Steel BS4190 Gr.8.0	All
19	Gland Stud/Bolt Nuts	Steel BS4190 Gr.8.0	All
20	Handwheel Washer	Steel BS 4320	All

Dimensional Drawing

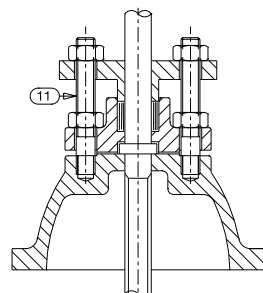
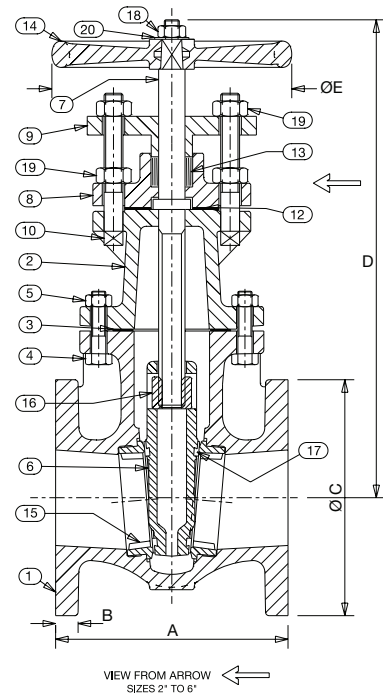

Dimensions & Weights

SIZE (inch)	WEIGHT (lbs)	A (inch)	B (inch)	ØC (inch)	D (inch)	ØE (inch)
2	30.0	5.75	0.75	6.0	11.1	5.5
2 1/2	35.1	6.25	0.75	6.5	11.9	5.5
3	44.1	6.5	0.75	7.25	13.5	6.0
4	60.0	6.75	0.88	8.5	14.8	8.0
5	86.0	7.5	0.88	10.0	17.2	9.0
6	98.1	8.25	0.88	11.0	18.8	9.0
8	178.0	9.5	1.0	13.25	24.0	12.0
10	271.0	10.75	1.0	16.0	28.9	14.0
12	384.0	12.0	1.0	18.0	33.3	16.0

SIZE (mm)	WEIGHT (kg)	A (mm)	B (mm)	ØC (mm)	D (mm)	ØE (mm)
50	13.6	146.1	19.1	152.0	281.6	139.7
65	15.9	158.8	19.1	165.1	301.7	139.7
80	20.0	165.1	19.1	184.0	343.0	152.4
100	27.2	171.5	22.2	215.9	374.7	203.2
125	39.0	190.5	22.2	254.0	436.8	228.6
150	44.5	209.6	22.2	279.4	478.2	228.6
200	81.6	241.3	25.4	337.0	609.1	304.8
250	122.9	273.1	25.4	406.0	732.9	355.6
300	174.2	304.8	28.6	457.2	844.6	406.4

PRESSURE RATING: Class 100

TEMPERATURE OPERATING RANGE: -10 to 170°C

UK END CONNECTION: BS10 Table D or E

OPERATING INSTRUCTIONS: Handwheel.

Gate valves are best for services that require infrequent valve operation, and where the disc is kept either fully opened or fully closed. They are not practical for throttling.

SPECIFICATION: End flanges conform to BS 10 Table D or E with flat face and are normally supplied drilled. Orders must specify whether Table D or Table E flanges are required. Wedge disc, non-rising stem, inside screw, all iron. Each valve is hydrostatically tested to BS 6755 Pt 1.

This valve is not suitable for use on group 1 gases or unstable fluids, as defined by the Pressure Equipment Directive 2014/68/EU.*

AVAILABLE OPTIONS: P150 Locking Device

Every effort has been made to ensure that the information contained in this publication is accurate at the time of publishing. Crane Ltd assumes no responsibility or liability for typographical errors or omissions or for any misinterpretation of the information within the publication and reserves the right to change without notice.

F58

Cast Iron Gate Valve

Class 125

F58

Features & Benefits

- Crane cast iron gate valves offer the ultimate in dependable service wherever minimum pressure drop is important
- Rising stem gives visual indication of valve open position

Materials

PART	MATERIAL	SIZES
Body	Cast Iron BS EN 1561 GJL-250	All
Bonnet	Cast Iron BS EN 1561 GJL-250	All
Disc	Cast Iron BS EN 1561 GJL-250	All
Stem	13% Cr.Steel BS 970 Pt.1 410S21 or 431S29	All
Body Seat Ring	Bronze BS EN 1982 CC491K	All
Disc Ring	Bronze BS EN 1982 CC491K	All
Yokesleeve	Bronze BS EN 1982 CC491K	All
Yokesleeve Nut	Ductile Iron ASTM A536 65-45-12	2, 3, 5, 8 & 10
Yokesleeve Nut	Cast Iron BS EN 1561 GJL-250	2 ¹ / ₂ , 4, 6 & 12
Yokesleeve Ret'g Nut	Ductile Iron ASTM A536 65-45-12	2, 3, & 5
Yokesleeve Ret'g Nut	Cast Iron BS EN 1561 GJL-250	2 ¹ / ₂ , 4, 6 & 12
Disc Stem Nut	Bronze BS EN 1982 CC491K	All
Gland	Cast Iron BS EN 1561 GJL-250	All
Packing	Asbestos Free	All
Gasket	Asbestos Free	All
Yoke	Cast Iron BS EN 1561 GJL-250	8, 10 & 12
Handwheel	Malleable Iron BS EN 1562 GJMB-300-6	All



GENERAL VALVES

Dimensional Drawing

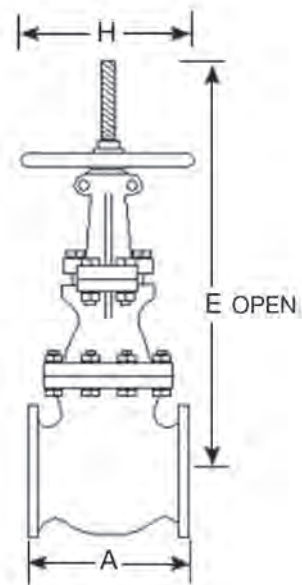

Dimensions & Weights

SIZE (inch)	WEIGHT (kg)	A (mm)	E (mm)	H (mm)
2	17	178	365	152
2 ¹ / ₂	20	190	448	152
3	28	203	481	203
4	38	229	622	229
5	56	254	672	254
6	60	267	835	254
8	112	292	989	305
10	185	330	1208	356
12	242	356	1469	406

Pressure/Temperature Ratings

TEMPERATURE (°C)	-10 to 65	230
PRESSURE (BAR)	13.8	8.6

Intermediate pressure ratings shall be determined by interpolation.

PRESSURE RATING: Class 125

TEMPERATURE OPERATING RANGE: -10 to 230°C

US END CONNECTION: ANSI Class 125

OPERATOR: Handwheel.

Gate valves are best for services that require infrequent valve operation, and where the disc is kept either fully opened or fully closed. They are not practical for throttling.

SPECIFICATION: Valves are manufactured in accordance with BS 5150: 1990. End flanges conform to BS 1560 section 3.2/ANSI B16.1 Class 125 with flat face and are normally supplied drilled. Wedge Disc, Rising Stem, Outside Screw and Yoke.

This valve is not suitable for use on group 1 gases or unstable fluids, as defined by the Pressure Equipment Directive 2014/68/EU.*

AVAILABLE OPTIONS: Flanges Undrilled. P50 Locking Device

* See page 155 for more information

Valid as of 290719

Every effort has been made to ensure that the information contained in this publication is accurate at the time of publishing. Crane Ltd assumes no responsibility or liability for typographical errors or omissions or for any misinterpretation of the information within the publication and reserves the right to change without notice.

F59

Cast Iron Gate Valve - Iron Trim

Class 125

F59

Features & Benefits

- Crane cast iron gate valves offer the ultimate in dependable service wherever minimum pressure drop is important

Materials

NO.	PART	MATERIAL	SIZES
1	Body	Cast Iron BS EN 1561 GJL-250	All
2	Bonnet	Cast Iron BS EN 1561 GJL-250	All
3	Bonnet Gasket	Asbestos Free	All
4	Bonnet Bolts/ Nuts Bronze	Steel BS4190 Gr.4.6/4.0	All
5	Disc	Cast Iron BS EN 1561 GJL-250	All
6	Stem	13% Cr.Steel	All
7	Stuffing Box	Cast Iron BS EN 1561 GJL-250	All
8	Gland	Cast Iron BS EN 1561 GJL-250	All
9	Gland Bolts	Steel BS 4190 Gr.4.6	200 & 250
9	Gland Studs	Steel BS 4439 Gr.4.8	50 - 150
10	Stuffing Box Gasket	Asbestos Free	All
11	Packing	Asbestos Free	All
12	Handwheel	Malleable Iron BS EN 1562 GJMB-300-6	All
13	Washer	Steel	All
14	Body Seat Ring	Integral	All
15	Disc Stem Nut	Ductile Iron ASTM A536 65-45-12	All
16	Handwheel Nut	Steel BS 4190 Gr.4	All
17	Stud/Bolt Nuts	Steel BS 4190 Gr.4	All



Dimensional Drawing

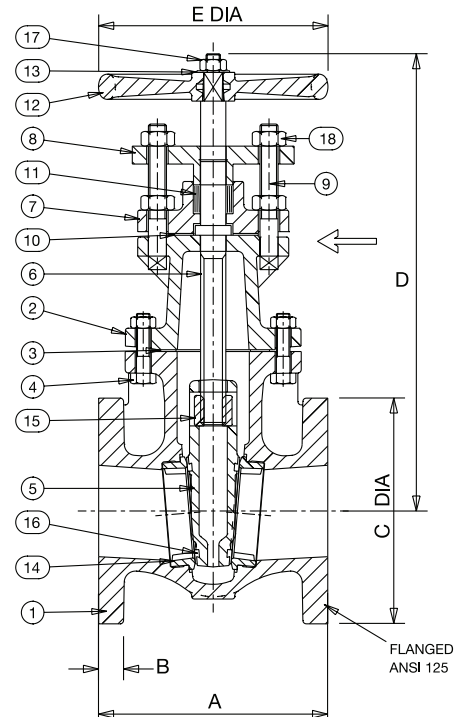

Dimensions & Weights

SIZE (mm)	WEIGHT (kg)	A (mm)	B (mm)	C (mm)	B (mm)	C (mm)
50	12.7	178	16	152	277	140
65	15.8	190	18	178	296	140
80	19.5	203	19	190	337	152
100	29.3	229	24	229	369	203
125	39.5	254	24	254	429	229
150	45.8	267	25	279	470	229
200	84	292	29	343	600	305
250	148	330	30	406	722	356

PRESSURE RATING: Class 125

TEMPERATURE OPERATING RANGE: -10 to 230°C

UK END CONNECTION: Not Specified

US END CONNECTION: ANSI Class 125

OPERATOR: Handwheel.

Gate valves are best for services that require infrequent valve operation, and where the disc is kept either fully opened or fully closed. They are not practical for throttling.

SPECIFICATION: Valves are manufactured in accordance with BS 5150. End flanges conform to BS 1560 Section 3.2/ANSI B16.1 Class 125 with flat face and are normally supplied drilled. Wedge Disc, Non-Rising Stem, Inside Screw, all Iron.

This valve is not suitable for use on group 1 gases or unstable fluids, as defined by the Pressure Equipment Directive 2014/68/EU.*

AVAILABLE OPTIONS: Flanges Undrilled, P50 Locking Device

Valid as of 290719

Every effort has been made to ensure that the information contained in this publication is accurate at the time of publishing. Crane Ltd assumes no responsibility or liability for typographical errors or omissions or for any misinterpretation of the information within the publication and reserves the right to change without notice.

F84

Cast Iron Gate Valve

Class 125

F84



GENERAL VALVES

Features & Benefits

- Crane cast iron gate valves offer the ultimate in dependable service wherever minimum pressure drop is important
- Each valve is manufactured in accordance with BS 5150: 1990
- Rising stem gives visual indication of valve open position

Materials

PART	MATERIAL	SIZES
Body	Cast Iron BS EN 1561 GJL-250	All
Bonnet	Cast Iron BS EN 1561 GJL-250	All
Disc	Bronze BS EN 1982 CC491K	2 - 4
Disc	Cast Iron BS EN 1561 GJL-250	5 - 12
Stem	Brass BS EN 12163 CW721R	2 - 4
Stem	Brass JIS - H3250 Gr.6872	5 - 12
Body Seat Ring	Bronze BS EN 1982 CC491K	All
Disc Ring	Bronze BS EN 1982 CC481K	5 - 12
Yoke	Cast Iron BS EN 1561 GJL-250	5 - 12
Yoke Hub Bolts/Nuts	Steel BS 4190 Gr.4.6/4	5 - 12
Yoke Pad Bolts/Nuts	Steel BS 4190 Gr.4.6/4	5 - 12
Yokesleeve	Manganese Bronze ASTM B584-C86400	2 - 4
Yokesleeve	Bronze BS EN 1982 CC491K	5 - 12
Yokesleeve Ret'g Nut	Malleable Iron BS EN 1562 GJMB-300-6	2 - 4
Yokesleeve Nut	Malleable Iron BS EN 1562 GJMB-300-6	2 - 4
Yokesleeve Nut	Ductile Iron ASTM A536 65-45-12	5 - 12
Gland	Malleable Iron BS EN 1562 GJMB-300-6	2 - 4
Gland	Cast Iron BS EN 1561 GJL-250	5 - 12
Gland Flange	Ductile Iron ASTM A536 65-45-12	5 - 12
Packing	Asbestos Free	All
Gasket	Asbestos Free	All
Handwheel	Malleable Iron BS EN 1562 GJMB-300-6	All
Body Plate	Aluminium	All

Dimensional Drawing

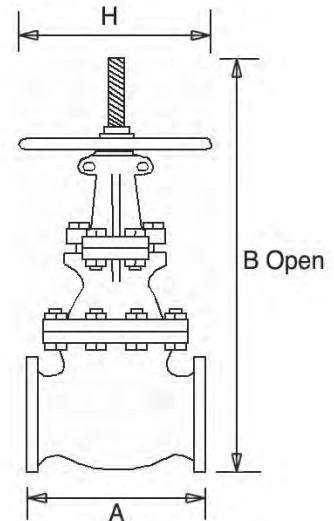

Dimensions & Weights

SIZE (inch)	WEIGHT (kg)	A (mm)	B (mm)	H (mm)
2	21.5	178	399	203
2½	24.8	190	432	203
3	29.5	203	469	203
4	42.7	229	566	229
5	72.3	254	714	305
6	88.1	267	813	305
8	140	292	1013	356
10	225	330	1257	406
12	314	356	1454	457

Pressure/Temperature Ratings

TEMPERATURE (°C)	-10 to 65	230
PRESSURE (BAR)	13.8	8.6

Intermediate pressure ratings shall be determined by interpolation.

PRESSURE RATING: Class 125

TEMPERATURE OPERATING RANGE: -10 to 230°C

US END CONNECTION: ANSI Flanged

OPERATOR: Handwheel.

Gate valves are best for services that require infrequent valve operation, and where the disc is kept either fully opened or fully closed. They are not practical for throttling.

SPECIFICATION: Valves meet the requirements of MSS.SP-70: 1998. End flanges conform to BS 1560 Section 3.2/ANSI B16.1. Class 125 with flat face and are normally supplied drilled. Wedge Disc, Rising Stem, Outside Screw and Yoke.

This valve is not suitable for use on group 1 gases or unstable fluids, as defined by the Pressure Equipment Directive 2014/68/EU.*

Valves tested in accordance with BS EN 12266-1: 2003.

AVAILABLE OPTIONS: Flanges Undrilled.

* See page 155 for more information

FM52

Cast Iron Gate Valve

PN6

FM52



Features & Benefits

- Crane cast iron gate valves offer the ultimate in dependable service wherever minimum pressure drop is important
- Complete with Bronze trim
- Each valve is hydrostatically tested to BS EN 12266-1: 2003
- Manufactured in accordance with BS EN 1171: 2002

Materials

PART	MATERIAL	SIZES
Body	Cast Iron BS EN 1561 GJL-250	All
Bonnet	Cast Iron BS EN 1561 GJL-250	All
Bonnet Gasket	Asbestos Free	All
Disc	Cast Iron BS EN 1561 GJL-250	All
Stem	Brass BS EN 12163 CW721R	All
Stuffing Box	Cast Iron BS EN 1561 GJL-250	All
Gland	Cast Iron BS EN 1561 GJL-250	All
Stuffing Box Gasket	Asbestos Free	All
Packing	Asbestos Free	All
Handwheel	Cast Iron	All
Body Seat Ring	Bronze BS EN 1982 CC491K	All
Disc Stem Nut	Bronze BS EN 1982 CC491K	All
Disc Ring	Bronze BS EN 1982 CC491K	All

Dimensional Drawing

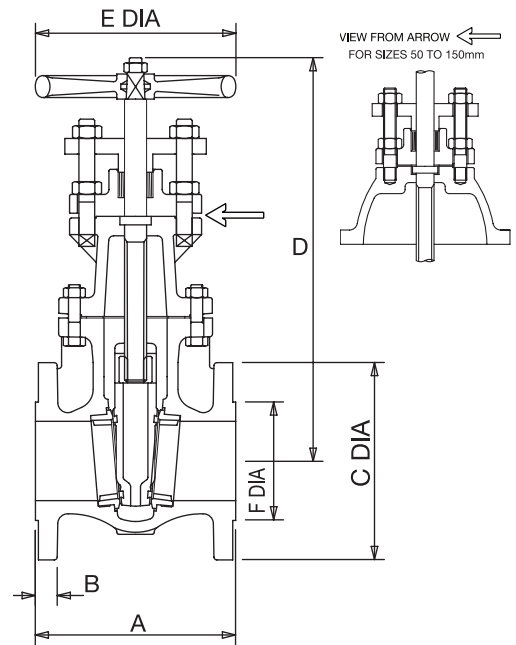

Dimensions & Weights

SIZE (mm)	WEIGHT (kg)	A (mm)	B (mm)	C (mm)	D (mm)	E (mm)	F (mm)
50	14	150	16	140	277	140	90
65	16	170	16	160	296	140	110
80	20	180	18	190	337	152	128
100	27	190	18	210	369	203	148
125	39	200	20	240	429	229	178
150	44	210	20	265	470	229	202
200	82	292	22	320	600	305	258
250	123	330	24	375	722	356	312
300	174	356	24	440	818	406	365

Pressure/Temperature Ratings

TEMPERATURE (°C)	-10 to 120	150
PRESSURE (BAR)	6	5.4

Intermediate pressure ratings shall be determined by interpolation.

PRESSURE RATING: PN6

TEMPERATURE OPERATING RANGE: -10 to 150°C

UK END CONNECTION: Flanged BS EN 1092-2 PN6

OPERATOR: Handwheel.

Gate valves are best for services that require infrequent valve operation, and where the disc is kept either fully opened or fully closed. They are not practical for throttling.

SPECIFICATION: Wedge Disc, Non-Rising Stem, Inside Screw and Yoke.

This valve is not suitable for use on group 1 gases or unstable fluids, as defined by the Pressure Equipment Directive 2014/68/EU.*

AVAILABLE OPTIONS: Flanges Undrilled.

* See page 155 for more information

FM57

Cast Iron Gate Valve

PN10

FM57



GENERAL VALVES

Features & Benefits

- Crane cast iron gate valves offer the ultimate in dependable service wherever minimum pressure drop is important
- Complete with Bronze trim
- Each valve is hydrostatically tested to BS EN 12266-1: 2003
- Manufactured in accordance with BS EN 1171: 2002

Materials

PART	MATERIAL	SIZES
Body	Cast Iron BS EN 1561 GJL-250	All
Bonnet	Cast Iron BS EN 1561 GJL-250	All
Bonnet Gasket	Asbestos Free	All
Disc	Cast Iron BS EN 1561 GJL-250	All
Stem	Brass BS 2874 CZ114	All
Stuffing Box	Cast Iron BS EN 1561 GJL-250	All
Gland	Cast Iron BS EN 1561 GJL-250	All
Stuffing Box Gasket	Asbestos Free	All
Packing	Asbestos Free	All
Handwheel	Cast Iron	All
Body Seat Ring	Bronze BS EN 1982 CC491K	All
Disc Stem Nut	Bronze BS EN 1982 CC491K	All
Disc Ring	Bronze BS EN 1982 CC491K	All

Dimensional Drawing

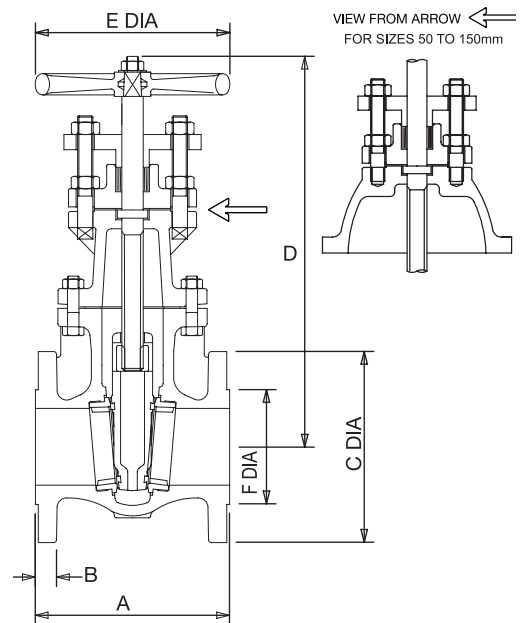

Dimensions & Weights

SIZE (mm)	WEIGHT (kg)	A (mm)	B (mm)	C (mm)	D (mm)	E (mm)	F (mm)
50	14	178	20	165	277	140	102
65	17	190	20	185	296	140	122
80	22	203	22	200	337	152	138
100	30	229	24	220	369	203	158
125	41	254	26	250	429	229	188
150	47	267	26	285	470	229	212
200	85	292	26	340	600	305	268
250	146	330	28	395	722	356	320
300	188	356	28	445	818	406	370

Pressure/Temperature Ratings

TEMPERATURE (°C)	-10 to 100	180
PRESSURE (BAR)	10	8.4

Intermediate pressure ratings shall be determined by interpolation.

PRESSURE RATING: PN10

TEMPERATURE OPERATING RANGE: -10 to 180°C

UK END CONNECTION: Flanged BS EN 1092-2: PN10

OPERATOR: Handwheel.

Gate valves are best for services that require infrequent valve operation, and where the disc is kept either fully opened or fully closed. They are not practical for throttling.

SPECIFICATION: Long Face-to-face, Wedge Disc, Non-Rising Stem.

Valves are manufactured in accordance with BS EN 1171: 2002. End flanges conform to BS EN 1092-2 PN10 with raised face and are normally supplied drilled.

This valve is not suitable for use on group 1 gases or unstable fluids, as defined by the Pressure Equipment Directive 2014/68/EU.*

AVAILABLE OPTIONS: Flanges Undrilled, P50 Locking Device

* See page 155 for more information

Valid as of 290719

Every effort has been made to ensure that the information contained in this publication is accurate at the time of publishing. Crane Ltd assumes no responsibility or liability for typographical errors or omissions or for any misinterpretation of the information within the publication and reserves the right to change without notice.

FM63

Cast Iron Gate Valve

PN16

FM63



Features & Benefits

- Crane cast iron gate valves offer the ultimate in dependable service wherever minimum pressure drop is important.
- Each valve is manufactured in accordance with BS EN 1171: 2002
- Hydrostatically tested to BS EN 12266-1: 2003

Materials

NO.	PART	MATERIAL
1	Body	Cast Iron BS EN 1561 GJL-250
2	Bonnet	Cast Iron BS EN 1561 GJL-250
3	Disc	Cast Iron BS EN 1561 GJL-250
4	Body Seat Ring	Bronze BS EN 1982 (CC491K)
5	Disc Seat Ring	Bronze BS EN 1982 (CC491K)
6	Stem	Stainless Steel BS 970: 410S21
7	Gasket	Graphite Graphite (Asbestos Free)
8	Gland Packing Nut	Stainless Steel BS 970: 304S31
9	Handwheel	Grey Iron BS EN 1561 EN-GJL-250
10	Stem Retaining Ring	Stainless Steel BS 970: 304S31
11	Disc Stem Nut	Bronze BS EN 1982 (CC491K)
12	Packing Ring	Graphite Graphite (Asbestos Free)
13	Body/Bonnet Bolt	Steel BS 3692 GR 8.8
14	Body/Bonnet Nut	Steel BS 3692 GR 8
15	Handwheel Retaining Nut	Steel BS 4190 GR 4
16	Handwheel Washer	Steel BS 4320
17	Body ID Plate (Not Shown)	Aluminium

Dimensional Drawing

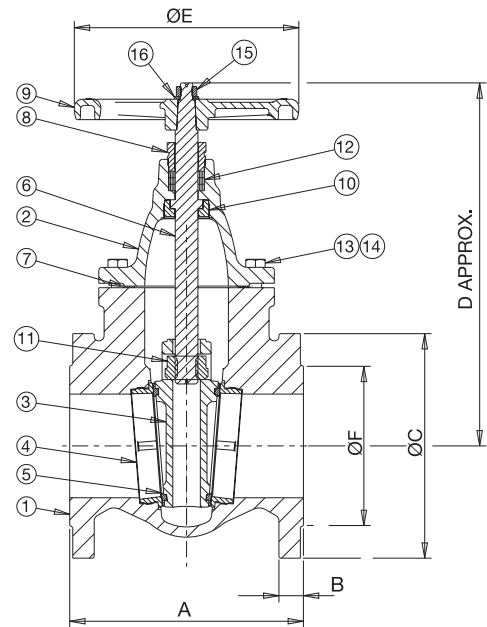

Dimensions & Weights

SIZE (mm)	WEIGHT (kg)	A (mm)	B (mm)	C (mm)	D (mm)	E (mm)	F (mm)
65	18.7	190	20	185	262	190	118
80	23.9	203	22	200	286	190	132
100	37.6	229	24	220	356	220	156
125	50.7	254	26	250	426	300	184
150	63.8	267	26	285	463	300	211
200	104.3	292	30	340	578	350	266
250	194.5	330	32	405	773	406	319
300	275.5	356	32	460	860	457	370

All dimensions are nominal.
Please note size 50mm is also available, please refer to the website.

Pressure/Temperature Ratings

TEMPERATURE (°C)	-10 to 120	200
PRESSURE (BAR)	16	12.8

Intermediate pressure ratings shall be determined by interpolation.

PRESSURE RATING: PN16

PRESSURE/TEMPERATURE OPERATING RANGE:

-10 to 120°C at 16 bar, 200°C at 12.8 bar

UK END CONNECTION: Flanged BS EN 1092-2: PN16

SPECIFICATION: Wedge Disc, Non-Rising Stem, Inside Screw, Handwheel operated.

This valve is not suitable for use on group 1 gases or unstable fluids, as defined by the Pressure Equipment Directive 2014/68/EU.*

AVAILABLE OPTIONS: Flanges Undrilled

FM82

Cast Iron Gate Valve

PN16

FM82



GENERAL VALVES

Features & Benefits

- Crane cast iron gate valves offer the ultimate in dependable service wherever minimum pressure drop is important
- Each valve is hydrostatically tested to BS EN 12266-1: 2003
- Manufactured in accordance with BS EN 1171: 2002
- Rising stem gives visual indication of valve open position

Materials

NO.	PART	MATERIAL
1	Body	Cast Iron BS EN 1561 GJL-250
2	Bonnet/Yoke	Cast Iron BS EN 1561 GJL-250
2	Bonnet	Cast Iron BS EN 1561 GJL-250
3	Disc	Cast Iron BS EN 1561 GJL-250
4	Stem	Stainless Steel 410 S21
5	Body Seat Ring	Bronze BS EN 1982 CC491K
6	Disc Seat Ring	Bronze BS EN 1982 CC491K
7	Yoke Sleeve	Bronze BS EN 1982 CC491K
8	Yoke Sleeve Retg Nut	Ductile Iron ASTM A536 65-45-12
9	Yoke Sleeve Nut	Malleable Iron BS EN 1562 GJMB 300-6
10	Gland Flange	Malleable Iron BS EN 1562 GJMB 300-6
11	Gland (2"-4")	Brass BS EN 12164 CW721R
11	Gland (5"-12")	Malleable Iron BS EN 1562 GJMB-300-6
13	Packing	Graphite
14	Bonnet Gasket	Graphite wrapped with SS304
16	Handwheel	Malleable Iron BS EN 1562 GJMB-300-6
18	Body Plate	Aluminium
20	Yoke	Cast Iron BS EN 1561 GJL-250

Dimensional Drawing

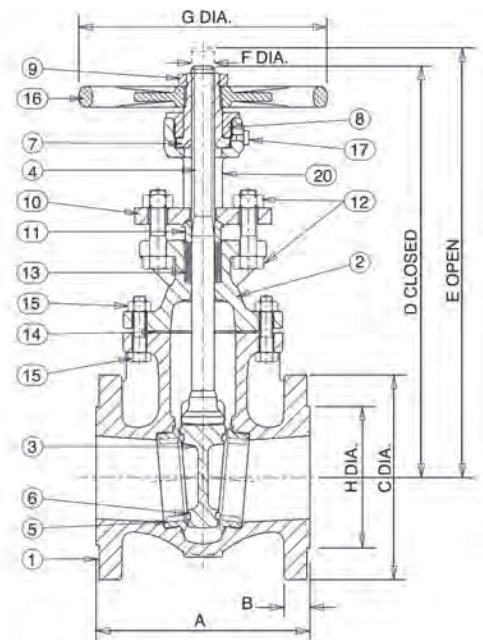

Dimensions & Weights

SIZE (mm)	WEIGHT (kg)	A (mm)	B (mm)	C (mm)	D (mm)	E (mm)	F (mm)	G (mm)	H (mm)
50	22.5	178	20	165	334	399	19	203	102
65	26.4	190	20	185	354	432	19	203	122
80	31	203	22	200	375	469	19	203	135
100	44.3	229	24	220	449	566	22	229	155
125	72.3	254	26	254	575	714	28.5	305	185
150	88.1	267	26	279	649	813	28.5	305	212
200	140	292	30	340	800	1013	34.9	356	248
250	225	330	32	405	984	1257	39.7	406	320
300	314	356	32	460	1127	1454	39.7	457	378

Pressure/Temperature Ratings

TEMPERATURE (°C)	-10 to 120	200
PRESSURE (BAR)	16	12.8

Intermediate pressure ratings shall be determined by interpolation.

PRESSURE RATING: PN16

TEMPERATURE OPERATING RANGE: -10 to 200°C

UK END CONNECTION: Flanged BS EN 1092-2 PN16

OPERATOR: Handwheel.

Gate valves are best for services that require infrequent valve operation, and where the disc is kept either fully opened or fully closed. They are not practical for throttling.

SPECIFICATION: Valves are manufactured in accordance with BS EN 1171: 2002.

End flanges conform to BS EN 1092-2 with raised face and are normally supplied drilled. Bronze Trim, Rising Stem.

This valve is not suitable for use on group 1 gases or unstable fluids, as defined by the Pressure Equipment Directive 2014/68/EU.*

AVAILABLE OPTIONS: Flanges Undrilled

* See page 155 for more information

33XU-F

Cast Steel Gate Valve

Class 300

33XU-F



Features & Benefits

- Efficient stop valves with flow in either direction
- Commonly used where a minimum pressure drop is important
- Flexible wedge disc compensates for deformation of body due to pipe stress
- Outside screw & yoke
- Flanged
- Seat ring is seal welded to eliminate leak paths

Materials

PART	MATERIAL
Body	A216 WCB
Bonnet	A216 WCB
Seat Rings	Hardfaced
Disc	CA-15 or 13% CR Overlay
Stem	410 SS
Packing	Graphite
Bonnet Gasket	Spiral Wound
Back Seat	410 SS
Yoke Sleeve	D2 Ni-Resist
Retaining Nut	Malleable or Steel
Disc Washer	Carbon Steel
Gland	Steel
Gland Flange	Steel
Eye Bolt	Steel
Eye Bolt Nuts	Steel
Pins	Steel
Bonnet Studs	A193 Gr. B7
Bonnet Nuts	A194 Gr. 2H
Handwheel	Malleable, Ductile or Steel
Handwheel Nut	Ductile or Steel
ID Tags	SS
ID Pins	Steel
Spacer	Steel
Grease Fittings	Steel

Dimensional Drawing

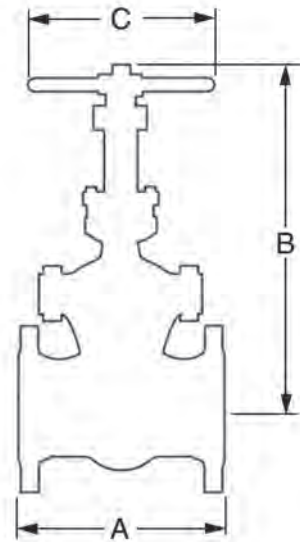

Dimensions & Weights

SIZE (inch)	WEIGHT (lbs)	A (inch)	B VALVE OPEN (inch)	C (inch)
2	74	8.50	16.00	8.00
2 1/2	80	9.50	19.00	8.00
3	108	11.12	22.00	9.00
4	165	12.00	25.00	10.00
6	320	15.88	32.75	14.00
8	500	16.50	40.00	16.00
10	760	18.00	49.50	18.00
12	1020	19.75	57.50	20.00
14	1380	30.00	64.50	20.00
16	1960	33.00	71.50	24.00
18	2450	36.00	78.50	23.62
20	3890	39.00	86.50	28.35
24	6292	45.00	104.00	35.43

Industry Standards

STEEL VALVES	ANSI B16.34
FACE-TO-FACE/END-TO-END	ANSI B16.10
FLANGE DIMENSIONS	ANSI B16.5
BASIC DESIGN	API 600
TESTING	API 598
ACCEPTANCE	API RP591

Intermediate pressure ratings shall be determined by interpolation.

SIZE RANGE: 2 - 24 inches **PRESSURE TEMPERATURE RATING:** Class 300
 Carbon Steel
 ASTM A216 Grade WCB
 740 psi @ -20°F to 100°F

Valid as of 290719

Every effort has been made to ensure that the information contained in this publication is accurate at the time of publishing. Crane Ltd assumes no responsibility or liability for typographical errors or omissions or for any misinterpretation of the information within the publication and reserves the right to change without notice.

47XU-F

Cast Steel Gate Valve

Class 150

Features & Benefits

- Efficient stop valves with flow in either direction
- Commonly used where a minimum pressure drop is important
- Flexible wedge disc compensates for deformation of body due to pipe stress
- Outside screw and yoke
- Flanged
- Seat ring is seal welded to eliminate leak paths

Materials

PART	MATERIAL
Body	A216 WCB
Bonnet	A216 WCB
Seat Rings	Hardfaced
Disc	CA-15 or 13% CR Overlay
Stem	410 SS
Packing	Graphite
Bonnet Gasket	Soft Iron
Back Seat	410 SS
Yoke Sleeve	D2 Ni-Resist
Retaining Nut	Malleable or Steel
Gland	Steel
Gland Flange	Steel
Eye Bolt	Steel
Eye Bolt Nuts	Steel
Pins	Steel
Bonnet Studs	A193 Gr. B7
Bonnet Nuts	A194 Gr. 2H
Handwheel	Malleable, Ductile or Steel
Handwheel Nut	Ductile or Steel
ID Tags	SS
ID Pins	Steel
Spacer	Steel
Grease Fittings	Steel



47XU-F

GENERAL VALVES

Dimensional Drawing

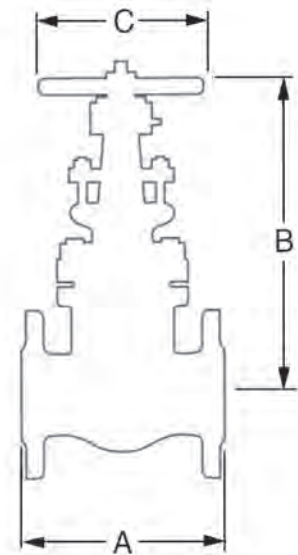

Dimensions & Weights

SIZE (inch)	WEIGHT (lbs)	A (inch)	B VALVE OPEN (inch)	C (inch)
2	46	7.00	16.50	8.00
2 1/2	70	7.50	18.00	8.00
3	76	8.00	21.00	9.00
4	110	9.00	23.00	10.00
6	175	10.50	31.00	12.00
8	310	11.50	39.00	14.00
10	455	13.00	46.75	16.00
12	650	14.00	55.00	18.00
14	860	15.00	60.50	20.00
16	1120	16.00	68.50	20.00
18	1400	17.00	77.50	23.62
20	2125	18.00	84.00	23.62
24	3120	20.00	99.00	28.35

Industry Standards

STEEL VALVES	ANSI B16.34
FACE-TO-FACE/END-TO-END	ANSI B16.10
FLANGE DIMENSIONS	ANSI B16.5
BASIC DESIGN	API 600
TESTING	API 598
ACCEPTANCE	API RP591

Intermediate pressure ratings shall be determined by interpolation.

SIZE RANGE: 2 - 24 inches **PRESSURE TEMPERATURE RATING:** Class 150

Carbon Steel
ASTM A216 Grade WCB
285 psi @ -20°F to 100°F

Valid as of 290719

Every effort has been made to ensure that the information contained in this publication is accurate at the time of publishing. Crane Ltd assumes no responsibility or liability for typographical errors or omissions or for any misinterpretation of the information within the publication and reserves the right to change without notice.

INFRASTRUCTURE

PROJECT

Qatar National Rail Scheme, Qatar

The QRail Doha scheme consists of a 300-kilometre metro network with four lines (red, gold, green & blue) with 80 stations; and light rail networks serving residential developments, such as Lusail, Education City and West Bay.

The Lusail LRT (Light Rail) project consist of four lines totalling 30km, 8 underground stations and 25 at-grade stations. Raed Line North will extend approximately 13 km northward from Musherib station, and has 7 underground stations. Two parallel tunnels will be excavated for a length of about 11.6 km and an internal diameter of 6.17 metres. Red Line South has 12 km long underground sections between Doha City Centre and the Airport. Green Line, has 15 km long underground sections which run north-south through the city. An over-ground extension to the underground tunnel section will have a total length of 3.2 km, of which 2.7 km will be a bridge from prefabricated components.

LOCATION:

Qatar

CLIENT:

Qatar Railways Development Company

CONTRACTOR:

ANEL MEP, Redco Int'l, Abantia, Cegelec, Saudi Bin Laden Group/Porr/HBK JV, TCS.

CONSULTANTS:

Jacobs Engineering, Louis Berger, Egis, Hill Int'l, Italferr SpA, WSP Parsons, Brinckerhoff, Astad, Atkins.

CHANNEL**PARTNER:**

AlRiyadh Trading & Contracting

SPECIFICATION:

Crane FS Pressure Independent Control Valves PICV, Balancing Valves & a wide selection of General Valves and Strainers



PROJECT

King's Cross Energy Centre



Crane FS Project Valves, including ball, butterfly, check and strainers were supplied via BSS for installation within the energy centre, which supplies heated water throughout the development at King's Cross, London. The 67-acre mixed

use development includes 2,000 new homes, new offices and retail space, 20 new streets and 10 public spaces, creating an entirely new piece of the city with its own postcode.

Crane FS valves will be installed in a site-wide Combined Heat and Power (CHP) driven hot water distribution network fed from a central energy centre. This is just one of the methods used on this site to cut energy consumption. Others include energy efficient buildings achieving a minimum BRE AAM of 'Excellent' roof-mounted wind turbines, ground source heat pumps and rainwater harvesting. The first buildings have been inhabited since autumn 2012.

LOCATION:

King's Cross, London

CLIENT:

King's Cross Central Limited Partnership

MAIN CONTRACTORS:

Carillion, BAM Construct, BAM Nuttall and Kier Group

M&E CONTRACTORS:

Vital Energi

DISTRIBUTOR:

BSS Ltd.

SPECIFICATION:

Wide range of project valves



Globe Valves

D7



Crane Fluid System globe valves are highly efficient for throttling service because seat and disc designs provide flow characteristics with proportionate relationships between valve lift and flow rate. This assures accurate flow control/ regulation. Globe valve bodies are normally of spherical shape, ensuring maximum strength against line pressures and pipeline strains. Wide faced hexagon ends on threaded valves provide a firm wrench grip which prevents damage to the valve. The majority of CFS globe valves are inside screw pattern, having either a screwed bonnet or union bonnet configuration. A wide choice of disc and seat materials is offered in this range to enable the user to select a valve most suited for the intended service.

There are five basic seat and disc arrangements available:

1. Metal to metal: the seat being integral with the body.
2. Renewable alloy or stainless steel disc and seat.
3. Renewable composition or elastomeric disc.
4. Renewable composition elastomeric disc alloy seat.
5. Vee-Reg pattern stainless steel disc and seat giving protection against wire drawing on steam service.

Fig. No.	PN / ANSI Rating	End Connections	Size Range	Disc Material	Body Material
D4	20	Threaded	1/4 - 2"	"Brass (1/2 - 1") Bronze (2")"	Bronze
D7	32	Threaded	1/4 - 3"	PTFE	Bronze
D10	Class 150	Threaded	1/4 - 3"	PTFE	Bronze
D14	32	Threaded	1/4 - 3"	Bronze	Bronze
D15	32	Threaded	1/4 - 3"	PTFE	Bronze
D16	32	Threaded	1/4 - 3"	Steel	Bronze
D46	40	Threaded	1/4 - 2"	Steel	Bronze
D52	64	Threaded	1/2 - 2"	Steel	Bronze
D71	32	Threaded	1/8 - 3/4"	Bronze	Bronze
D72	32	Threaded	1/8 - 3/4"	Bronze	Bronze
DM6	16	Flanged	1/2 - 2"	Bronze	Bronze
DM11	25	Flanged	1/2 - 3"	PTFE	Bronze
F372	Class 125	Flanged	2 - 6"	Bronze	Cast Iron
FM369	16	Flanged	50 - 150mm	Bronze	Cast Iron
143XU	Class 150	Flanged	2 - 12"	Steel	Cast Steel
151XU	Class 300	Flanged	2 - 12"	Steel	Cast Steel

† WRAS approved product

D4

Bronze Globe Valve - Series B



PN20

D4

GENERAL VALVES



Features & Benefits

- Crane bronze globe valves are highly efficient for throttling because seat and disc designs provide flow characteristics with proportionate relationships between valve lift and flow rate
- This valve carries the British Standards Institution kitemark – your assurance of exacting quality

Materials

PART	MATERIAL	SIZES
Body	Bronze BS EN 1982 CC491K	All
Bonnet	Bronze BS EN 1982 CC491K	All
Disc	Brass BS EN 12164 CW614N	1/4 - 1 1/2
Disc	Bronze BS EN 1982 CC491K	2"
Stem	Brass BS EN 12164 CW614N	All
Packing	Asbestos Free	All
Gland	Brass BS EN 12164 CW614N	All
Packing Nut	Brass BS EN 12164 CW614N	All
Disc Stem Ring	Manganese Bronze BS EN 12164 CW721R	2" only
Handwheel	Aluminium	All
Handwheel Nut	Brass BS EN 12164 CW614N	All
ID Plate	Aluminium	All

Dimensional Drawing

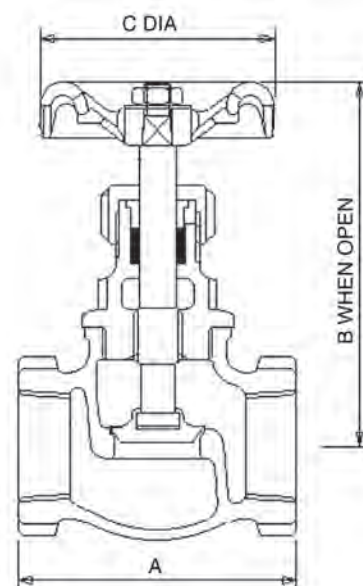

Dimensions & Weights

SIZE (inch)	WEIGHT (kg)	A (mm)	B (mm)	C (mm)
1/4	0.23	44	75	52
3/8	0.22	44	75	52
1/2	0.31	55	82	52
3/4	0.42	63	89	52
1	0.71	77	102	65
1 1/4	1.12	91	118	70
1 1/2	1.5	98	134	78
2	2.48	118	171	103

Pressure/Temperature Ratings

TEMPERATURE (°C)	-10 to 100	80
PRESSURE (BAR)	20	9

Intermediate pressure ratings shall be determined by interpolation.

PRESSURE RATING: PN20

TEMPERATURE OPERATING RANGE: -10 to 180°C

UK END CONNECTION: Taper threaded to BS EN 10226-2 (ISO 7-1) formerly BS 21

US END CONNECTION: ANSI B1.20.1

OPERATOR: Handwheel.

SPECIFICATION: Valves are manufactured in accordance with BS 5154: 1991 PN20 for Series B ratings. Body seat is integral and is a narrow contact angled type.

Sizes 1/4" to 2" taper threaded to BS EN 10226-2 (ISO 7-1) formerly BS 21 versions BSI Kitemarked.

Metal Disc, Screwed Bonnet.

This valve is not suitable for use on group 1 gases or unstable fluids, as defined by the Pressure Equipment Directive 2014/68/EU.*

* See page 155 for more information

Valid as of 290719

Every effort has been made to ensure that the information contained in this publication is accurate at the time of publishing. Crane Ltd assumes no responsibility or liability for typographical errors or omissions or for any misinterpretation of the information within the publication and reserves the right to change without notice.

D7

Bronze Globe Valve

PN32

D7

Features & Benefits

- Crane bronze globe valves are highly efficient for throttling because seat and disc designs provide flow characteristics with proportionate relationships between valve lift and flow rate

Materials

NO.	PART	MATERIAL	SIZES
1	Body	Bronze BS EN 1982 CC491K	All
2	Bonnet	Bronze BS EN 1982 CC491K	All
3	Stem	Brass BS EN 12163 CW721R	1/4 - 2
3	Stem	Bronze BS EN 1982 CC491K	2 1/2 & 3
4	Disc	PTFE - 25% Glass Filled	All
5	Disc Holder	Bronze BS EN 1982 CC491K	1 1/4 - 3
5	Disc Holder	Brass BS EN 12164 CW617N	1/4 - 1
6	Union Ring	Bronze BS EN 1982 CC491K	1/4, 3/8, 1/2 & 2
6	Union Ring	Brass BS EN 12164 CW617N	3/4 - 1 1/2
7	Packing	Asbestos Free	All
8	Packing Gland	Brass BS EN 12164 CW614N	All
9	Packing Nut	Brass BS EN 12164 CW614N	1/4 - 1 1/2
9	Packing Nut	Bronze BS EN 1982 CC491K	2 - 3
10	Washer	Brass BS EN 12164 CW614N	1/4 - 2
11	Disc Ret'ng Nut	Brass BS EN 12164 CW614N	1/4 - 2
11	Disc Ret'ng Nut	Bronze BS EN 1982 CC491K	2 1/2 & 3
12	Handwheel	Aluminium	1/4 - 2
12	Handwheel	Malleable Iron BS EN 1562 GJMB-300-6	2 1/2 & 3
13	Handwheel Nut	Brass BS EN 12164 CW614N	All
14	ID Plate	Aluminium	All
15	Disc Stem Ring	Brass BS EN 12163 CW721R	1/4 - 2
15	Disc Stem Ring	Bronze BS EN 1982 CC491K	2 1/2 & 3
16	Bonnet Stud	Steel BS 970 070M20	2 1/2 & 3
17	Bonnet Stud Nut	Steel BS 4190 Gr.4	2 1/2 & 3
18	Gasket	Asbestos Free	2 1/2 & 3



Dimensional Drawing

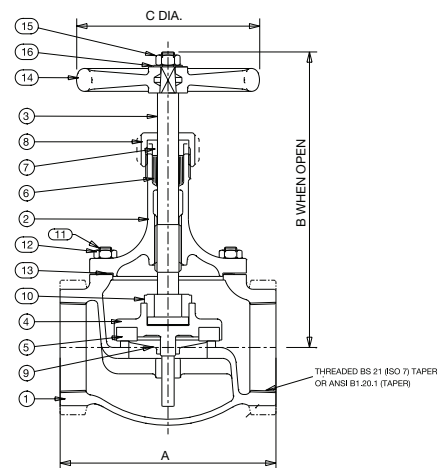
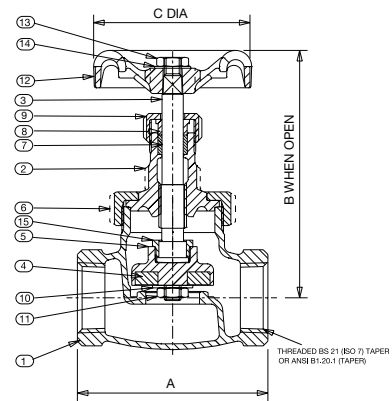

Dimensions & Weights

SIZE (inch)	WEIGHT (kg)	A (mm)	B (mm)	C (mm)
1/4	0.5	52	100	52
3/8	0.49	52	100	52
1/2	0.73	62	101	52
3/4	1.09	74	115	52
1	1.74	90	125	70
1 1/4	2.44	100	150	70
1 1/2	3.32	115	159	92
2	5.54	136	191	103
2 1/2	10.9	184	278	152
3	16.4	210	308	178

PRESSURE RATING: PN32

TEMPERATURE OPERATING RANGE: -10 to 198°C

UK END CONNECTION: BS 21 Taper

US END CONNECTION: ANSI B1.20.1

OPERATOR: Handwheel.

AVAILABLE OPTIONS: P150 Locking Device

SPECIFICATION: Valves are manufactured in accordance with BS 5154 PN32 for Series B ratings.

Design incorporates a disc holder with on sizes 1/4" to 2" slips on to stem, and on sizes 2 1/2" and 3" is retained by a threaded ring. Sizes 1/4" to 3" BS 21 versions BSI Kitemarked.

Body seat is integral of the semi-crown type. Sizes 1/4" to 2" have union bonnet and sizes 2 1/2" and 3" have a bolted bonnet. Valves having ANSI threads also generally conform to MSS SP-80.

This valve is not suitable for use on group 1 gases or unstable fluids, as defined by the Pressure Equipment Directive 2014/68/EU.*

* See page 155 for more information

Valid as of 290719

Every effort has been made to ensure that the information contained in this publication is accurate at the time of publishing. Crane Ltd assumes no responsibility or liability for typographical errors or omissions or for any misinterpretation of the information within the publication and reserves the right to change without notice.

D10

Bronze Globe Valve

Class 150

Features & Benefits

- Crane bronze globe valves are highly efficient for throttling because seat and disc designs provide flow characteristics with proportionate relationships between valve lift and flow rate

Materials

NO.	PART	MATERIAL	SIZES
1	Body	Bronze BS EN 1982 CC491K	All
2	Bonnet	Bronze BS EN 1982 CC491K	All
3	Stem	Bronze BS EN 1982 CC491K	All
4	Disc	PTFE (25% Glass Filled)	All
5	Disc Holder	Bronze BS EN 1982 CC491K	1 1/4 - 3
5	Disc Holder	Brass BS EN 12165 CW617N	1/2 - 1
6	Union Ring	Bronze BS EN 1982 CC491K	1/2 - 2
7	Packing	Asbestos Free	All
8	Gland	Brass BS EN 12164 CW614N	All
9	Packing Nut	Brass BS EN 12164 CW614N	1/2 - 1 1/2
9	Packing Nut	Bronze BS EN 1982 CC491K	2 - 3
10	Washer	Brass BS EN 12164 CW614N	1/2 - 2
11	Disc Ret'ng Nut	Brass BS EN 12164 CW614N	1/2 - 2
11	Disc Ret'ng Nut	Bronze BS EN 1982 CC491K	2 1/2 & 3
12	Handwheel	Aluminium	1/2 - 2
12	Handwheel	Malleable Iron BS EN 1562 GJMB-300-6	2 1/2 & 3
13	Handwheel Nut	Brass BS EN 12164 CW614N	All
14	ID Plate	Aluminium	All
15	Disc Stem Ring	Bronze BS EN 1982 CC491K	2 1/2 & 3
16	Bonnet Stud	Steel BS 970 070M20	2 1/2 & 3
17	Bonnet Stud Nut	Steel BS 4190 Gr.4	2 1/2 & 3
18	Gasket	Asbestos Free	2 1/2 & 3

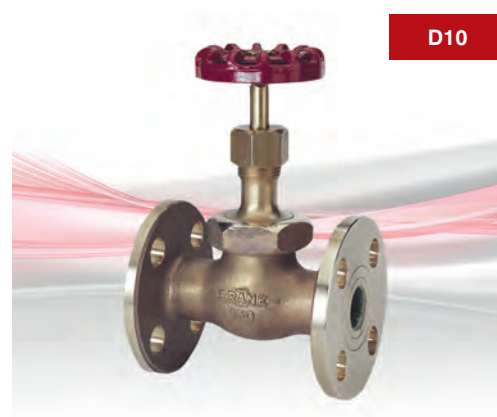

Dimensional Drawing

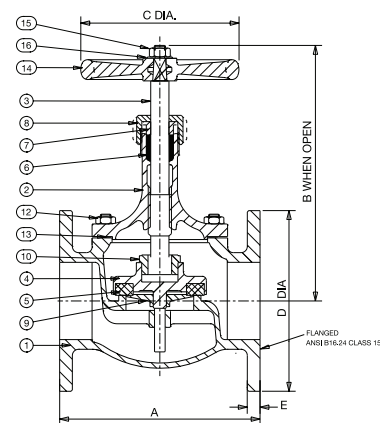
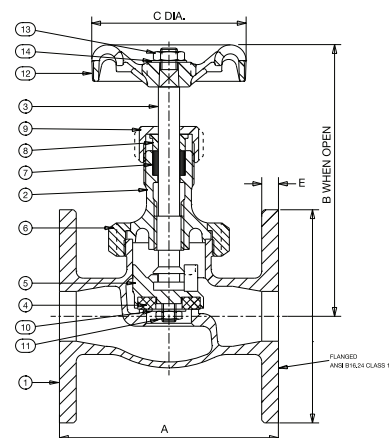

Dimensions & Weights

SIZE (mm)	WEIGHT (kg)	A (mm)	B (mm)	C (mm)	D (mm)	E (mm)
1/2	1.76	108	128	65	89	8
3/4	1.95	117	145	70	98	9
1	3.2	127	161	78	108	10
1 1/4	4.54	146	180	92	118	10
1 1/2	6.12	159	199	103	127	11
2	8.67	190	233	121	152	13
2 1/2	14.9	216	279	152	178	14
3	20.1	254	313	152	191	16

PRESSURE RATING: Class 150

TEMPERATURE OPERATING RANGE: -10 to 186°C

UK END CONNECTION: Not Specified

US END CONNECTION: Flanged Class 150

OPERATOR: Handwheel

AVAILABLE OPTOINS: Flanges Undrilled.

P150 Locking Device

SPECIFICATION: Valves are manufactured in accordance with BS 5154 for Class 150 Series B ratings.

Design incorporates a disc holder retained on a stem by a threaded ring. Body seat is integral of the semi-crown type. Sizes 1/2" to 2" have a union bonnet; sizes 2 1/2" and 3" have a bolted bonnet. End flanges conform to BS 1560 Section 3.3 and ANSI B16.24 Class 150 with flat face and are normally supplied drilled. Valves have BS 5154 'long' face-to-face.

Valves also generally conform to MSS SP-80.

This valve is not suitable for use on group 1 gases or unstable fluids, as defined by the Pressure

Equipment Directive 2014/68/EU.*

* See page 155 for more information

Valid as of 290719

Every effort has been made to ensure that the information contained in this publication is accurate at the time of publishing. Crane Ltd assumes no responsibility or liability for typographical errors or omissions or for any misinterpretation of the information within the publication and reserves the right to change without notice.

D14

Bronze Globe Valve - Series A

PN32*

D14



Features & Benefits

- Crane bronze globe valves are highly efficient for throttling because seat and disc designs provide flow characteristics with proportionate relationships between valve lift and flow rate.
- *Sizes 2 1/2" & 3" rated PN25

Materials

PART	MATERIAL	SIZES
Body	Bronze BS EN 1982 CC491K	All
Bonnet	Bronze BS EN 1982 CC491K	All
Disc Stem Ring	Brass BS EN 12163 CW721R	All
Disc	Bronze BS EN 1982 CC491K	All
Stem	Manganese Bronze BS EN 12163 CW721R	All
Gland	Brass BS EN 12164 CW614N	All
Packing	Asbestos Free	All
Packing Nut	Brass BS EN 12164 CW614N	1/4 - 2 1/2
Packing Nut	Bronze BS EN 1982 CC491K	3" only
Handwheel	Aluminium	1/4 - 2 1/2
Handwheel	Malleable Iron BS EN 1562 GJMB-300-6	3" only
Handwheel Nut	Brass BS EN 12164 CW614N	All
ID Plate	Aluminium	All
Gasket	Asbestos Free	2 1/2 - 3

Dimensional Drawing

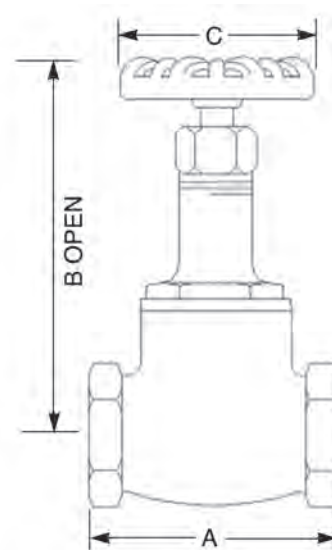

Dimensions & Weights

SIZE (inch)	WEIGHT (kg)	A (mm)	B (mm)	C (mm)
1/4	0.39	52	100	52
3/8	0.38	52	100	52
1/2	0.54	62	101	52
3/4	0.65	74	115	52
1	0.9	90	125	70
1 1/4	1.58	100	150	70
1 1/2	2.06	115	159	92
2	3.31	136	191	103
2 1/2	5.9	166	220	121
3	10.3	190	255	152

Pressure/Temperature Ratings

TEMPERATURE (°C)	-10 to 100	260
PRESSURE (BAR)	32	14

Intermediate pressure ratings shall be determined by interpolation.

PRESSURE RATING: PN32

TEMPERATURE OPERATING RANGE: -10 to 260°C

UK END CONNECTION: Taper threaded to BS EN 10226-2 (ISO 7-1) formerly BS 21

US END CONNECTION: ANSI B1.20.1

OPERATOR: Handwheel

SPECIFICATION: Valves are manufactured in accordance with BS 5154:1991 series A, PN32 for sizes 1/4" to 2" and PN25 for sizes 2 1/2" and 3".

Design incorporates a bronze 35 degree wide angle disc retained on stem by a threaded ring; body seat is integral of the narrow contact angled type.

This valve is not suitable for use on group 1 gases or unstable fluids, as defined by the Pressure Equipment Directive 2014/68/EU.*

* See page 155 for more information

D15

Bronze Globe Valve - Series B



PN32*

D15

GENERAL VALVES



Features & Benefits

- The Crane D15 bronze globe valve is highly efficient for throttling service
- *Sizes 2 1/2" & 3" are rated PN25
- This valve carries the British Standards Institution kitemark – your assurance of exacting quality

Materials

PART	MATERIAL	SIZES
Body	Bronze BS EN 1982 CC491K	All
Bonnet	Bronze BS EN 1982 CC491K	All
Disc Stem Ring	Brass BS EN 12163 CW721R	All
Disc	PTFE (25% Glass Filled)	All
Disc Holder	Bronze BS EN 1982 CC491K	1 1/4 - 3
Disc Holder	Brass BS EN 12165 CW617N	1/4 - 1
Disc Retaining Nut	Brass BS EN 12164 CW614N	1/4 - 2
Disc Retaining Nut	Bronze BS EN 1982 CC491K	2 1/2 & 3
Washer	Brass BS EN 12164 CW614N	1/4 - 2 only
Stem	Brass BS EN 12163 CW721R	1/4 - 2
Stem	Manganese Bronze	2 1/2 & 3
Gland	Brass BS EN 12164 CW614N	All
Packing	Asbestos Free	All
Packing Nut	Brass BS EN 12164 CW614N	1/4 - 2
Packing Nut	Bronze BS EN 1982 CC491K	2 1/2 - 3
Handwheel	Aluminium	1/4 - 2 1/2
Handwheel	Malleable Iron BS EN 1562 GJMB-300-6	3" only
Handwheel Nut	Brass BS EN 12164 CW614N	All
ID Plate	Aluminium	All
Gasket	Asbestos Free	2 1/2 only
Gasket	Stainless Steel	3" only

Dimensional Drawing

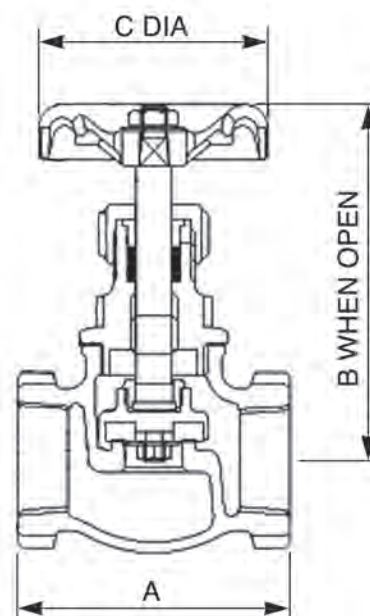

Dimensions & Weights

SIZE (inch)	WEIGHT (kg)	A (mm)	B (mm)	C (mm)
1/4	0.4	52	100	52
3/8	0.39	52	100	52
1/2	0.54	62	101	52
3/4	0.65	74	115	52
1	0.81	90	125	70
1 1/4	1.55	100	150	70
1 1/2	2.01	115	159	92
2	3.08	136	191	103
2 1/2	6.1	166	220	121
3	10.5	190	255	152

Pressure/Temperature Ratings

TEMPERATURE (°C)	-10 to 100	198
PRESSURE (BAR)	32	14

Intermediate pressure ratings shall be determined by interpolation.

PRESSURE RATING: PN32

TEMPERATURE OPERATING RANGE: -10 to 198°C

UK END CONNECTION: Taper threaded to BS EN 10226-2 (ISO 7-1) formerly BS 21

US END CONNECTION: ANSI B1.20.1

OPERATOR: Handwheel

Valid as of 290719

Every effort has been made to ensure that the information contained in this publication is accurate at the time of publishing. Crane Ltd assumes no responsibility or liability for typographical errors or omissions or for any misinterpretation of the information within the publication and reserves the right to change without notice.

D16

Bronze Globe Valve – Series A

PN32*

D16



Features & Benefits

- Crane Bronze globe valves are highly efficient for throttling because seat and disc designs provide flow characteristics with proportionate relationships between valve lift and flow rate
- *Please note Sizes 2 1/2" and 3" are rated at PN25

Materials

PART	MATERIAL	SIZES
Body	Bronze BS EN 1982 CC491K	All
Bonnet	Bronze BS EN 1982 CC491K	All
Body Seat Ring	13% Cr.Steel BS970 Pt.1 410S21 or 431S29	All
Disc Stem Ring	Brass BS EN 12163 CW721R	All
Disc	13% Cr.Steel BS970 Pt.1 410S21 or 431S29	1/2 - 2
Disc	Nickel Alloy	1/4, 3/8, 2 1/2 & 3
Stem	Manganese Bronze BS EN 12163 CW721R	All
Gland	Brass BS EN 12164 CW614N	All
Packing	Asbestos Free	All
Packing Nut	Brass BS EN 12164 CW614N	1/4 - 2 1/2
Packing Nut	Bronze BS EN 1982 CC491K	3" only
Handwheel	Aluminium	1/4 - 2 1/2
Handwheel	Malleable Iron BS EN 1562 GJMB-300-6	3" only
Handwheel Nut	Brass BS EN 12164 CW614N	All
ID Plate	Aluminium	All
Gasket	Asbestos Free	2 1/2 - 3

Dimensional Drawing

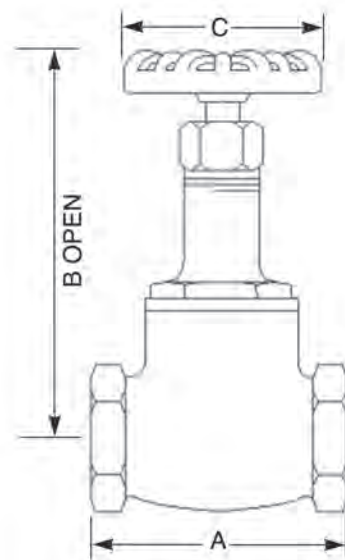

Dimensions & Weights

SIZE (inch)	WEIGHT (kg)	A (mm)	B (mm)	C (mm)
1/4	0.33	52	100	52
3/8	0.31	52	100	52
1/2	0.8	62	101	52
3/4	1.24	74	115	52
1	1.5	90	125	70
1 1/4	1.7	100	150	70
1 1/2	2.16	115	159	92
2	3.67	136	191	103
2 1/2	6	166	220	121
3	10.9	190	255	178

Pressure/Temperature Ratings

TEMPERATURE (°C)	-10 to 100	260
PRESSURE (BAR)	32	14

Intermediate pressure ratings shall be determined by interpolation.

PRESSURE RATING: PN32

TEMPERATURE OPERATING RANGE: -10 to 260°C

UK END CONNECTION: Taper threaded to BS EN 10226-2 (ISO 7-1) formerly BS 21

US END CONNECTION: ANSI B1.20.1

OPERATOR: Handwheel

SPECIFICATION: Valves are manufactured in accordance with BS 5154: 1991 Series A, PN32 for sizes 1/4" to 2" and PN25 for sizes 2 1/2" and 3".

Design incorporates a nickel alloy plug type disc retained on the stem by a threaded ring; body seat is a screwed-in stainless steel ring.

This valve is not suitable for use on group 1 gases or unstable fluids, as defined by the Pressure Equipment Directive 2014/68/EU.*

* See page 155 for more information

D46

D46

Bronze Globe Valve

PN40

Features & Benefits

- Crane bronze globe valves are highly efficient for throttling because seat and disc designs provide flow characteristics with proportionate relationships between valve lift and flow rate



GENERAL VALVES

Materials

NO.	PART	MATERIAL	SIZES
1	Body	Bronze BS EN 1982 CC491K	All
2	Bonnet	Bronze BS EN 1982 CC491K	All
3	Stem	Brass BS EN 12163 CW721R	1/4 - 2
4	Disc	Duplex Stainless Steel S32205	All
5	Union Ring	Bronze BS EN 1982 CC491K	1/4 - 2
6	Packing	Asbestos Free	All
7	Gland	Brass BS EN 12164 CW614N	All
8	Packing Nut	Brass BS EN 12164 CW614N	1/4 - 2
8	Packing Nut	Bronze BS EN 1982 CC491K	2 - 3
9	Body Seat Ring	13% Cr.Steel BS 970 Pt.1 410S21/431S29	All
10	Disc Stem Ring	Brass BS EN 12164 CW721R	1/4 - 2
11	Lockwasher	Brass BS EN 1652 CuZn 40Pb	All
12	Bonnet Stud	Steel BS 970 070M20	2 1/2 & 3
13	Bonnet Stud Nut	Steel BS 4190 Gr.4	2 1/2 & 3
14	Gasket	Asbestos Free	2 1/2 & 3
15	Handwheel	Aluminium	1/4 - 2
16	Handwheel Nut	Brass BS EN 12164 CW614N	All
17	ID Plate	Aluminium	All

Dimensional Drawing

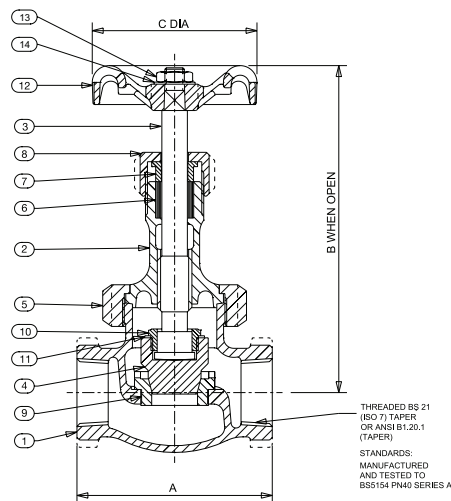
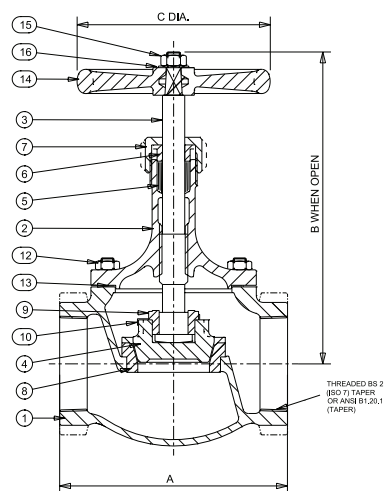

Dimensions & Weights

SIZE (inch)	WEIGHT (kg)	A (mm)	B (mm)	C (mm)
1/4	0.53	59	122	52
3/8	0.55	59	122	52
1/2	0.8	68	140	65
3/4	1.24	81	152	70
1	1.82	95	171	78
1 1/4	2.73	108	193	92
1 1/2	3.78	121	220	103
2	6.03	146	251	121

PRESSURE RATING: PN40

TEMPERATURE OPERATING RANGE: -10 to 260°C

UK END CONNECTION: BS 21 Taper

US END CONNECTION: ANSI B1.20.1

OPERATOR: Handwheel

AVAILABLE OPTOINS: P150 Locking Device

SPECIFICATION: Valves are manufactured in accordance with BS 5154 PN40 for series A ratings.

Design incorporates Duplex Stainless Steel S32205 plug type disc retained on stem by a threaded ring.

The body seat is screwed-in stainless steel ring. Sizes 1/4" to 2" have a union bonnet and sizes 2 1/2" and 3" have a bolted bonnet.

This valve is not suitable for use on group 1 gases or unstable fluids, as defined by the Pressure Equipment Directive 2014/68/EU.*

Valves having ANSI threads also generally conform to MSS SP-80.

* See page 155 for more information

Valid as of 290719

Every effort has been made to ensure that the information contained in this publication is accurate at the time of publishing. Crane Ltd assumes no responsibility or liability for typographical errors or omissions or for any misinterpretation of the information within the publication and reserves the right to change without notice.

D52

Bronze Globe Valve

PN64

D52



Features & Benefits

- Crane bronze globe valves are highly efficient for throttling because seat and disc designs provide flow characteristics with proportionate relationships between valve lift and flow rate.
- This valve features a renewable nickel alloy plug disc and a stainless steel seat.

Materials

NO.	PART	MATERIAL	SIZES
1	Body	Bronze BS EN 1982 CC491K	All
2	Bonnet	Bronze BS EN 1982 CC491K	All
3	Stem	Aluminium Bronze NES 834 Pt.2	All
4	Disc	Duplex Stainless Steel S32205	All
5	Union Ring	Bronze BS EN 1982 CC491K	All
5	Disc Holder	Brass BS EN 12165 CW617N	1/2 - 1
6	Packing	Asbestos Free	All
7	Gland	Brass BS EN 12164 CW614N	All
8	Packing Nut	Bronze BS EN 1982 CC491K	1 1/2 & 2
8	Packing Nut	Brass BS EN 12164 CW614N	1/2 - 1 1/4
9	Body Seat Ring	13% Cr.Steel BS 970 Pt.1 410S21	All
10	Disc Stem Ring	Aluminium Bronze NES 834 Pt.2	All
11	Disc Retaining Unit	Brass BS EN 12164 CW614N	1/2 - 2
11	Lockwasher	Brass BS EN 1652 CuZn 40Pb	All
12	Handwheel	Aluminium	1/2 - 1 1/2
12	Handwheel	Malleable Iron BS EN 1562 GJMB-300-6	2" only
13	Handwheel Nut	Brass BS EN 12164 CW614N	All
14	ID Plate	Aluminium	All

Dimensional Drawing

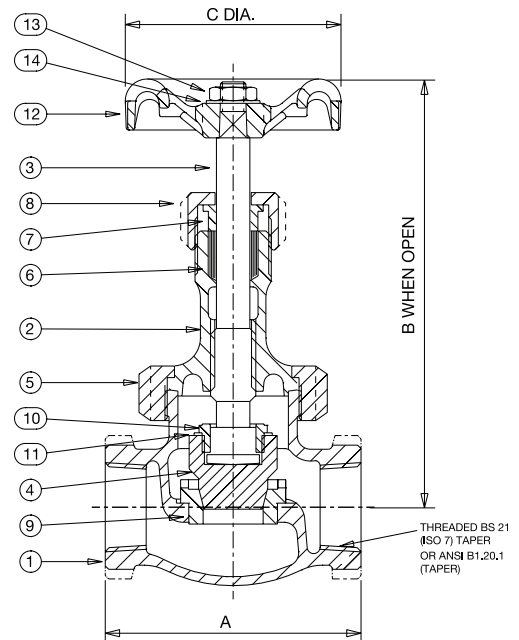

Dimensions & Weights

SIZE (inch)	WEIGHT (kg)	A (mm)	B (mm)	C (mm)
1/4	1	75	134	70
3/4	1.51	89	159	78
1	2.25	105	177	92
1 1/4	3.59	121	200	103
1 1/2	5.05	133	228	121
2	8.5	162	262	152

PRESSURE RATING: PN64

TEMPERATURE OPERATING RANGE:
-10 to 288°C

UK END CONNECTION: BS 21 Taper

US END CONNECTION: Not Specified

OPERATOR: Handwheel

AVAILABLE OPTIIONS:

P150 Locking Device

SPECIFICATION: Valves having PN64 ratings are not specified in BS 5154.

D52 valves meet the requirements of BS 5154 in respect to materials design and method of manufacture as far as applicable.

Design incorporates a Duplex Stainless Steel S32205 plug type disc retained on the stem by a threaded ring. The body seat is a screwed-in stainless steel ring.

Valves having ANSI threads also generally conform to MSS SP-80.

Not suitable for use on unstable fluids as defined by the Pressure Equipment Directive 2014/68/EU.*

* See page 155 for more information

Valid as of 290719

Every effort has been made to ensure that the information contained in this publication is accurate at the time of publishing. Crane Ltd assumes no responsibility or liability for typographical errors or omissions or for any misinterpretation of the information within the publication and reserves the right to change without notice.

D71

Globe Valve

PN32

D71

GENERAL VALVES

Features & Benefits

- Crane bronze globe valves are highly efficient for throttling because seat and disc designs provide flow characteristics with proportionate relationships between valve lift and flow rate.



Materials

NO.	PART	MATERIAL	SIZES
1	Body	Bronze BS EN 1982 CC491K	-
2	Bonnet	Sil. Al. Bronze BS EN 12163 CW301G	1/8 - 3/8
2	Bonnet	Brass BS EN 12164 CW614N	3/4
3	Stem	Sil. Al. Bronze BS EN 12163 CW301G	-
4	Packing*	Asbestos Free	-
5	Gland	Brass BS EN 12164 CW614N	-
6	Packing Nut	Brass BS EN 12164 CW614N	-
7	Handwheel	Aluminium	-
8	Handwheel Nut	Brass BS EN 12164 CW614N	-
9	Identity Plate	Aluminium	-

*Recommended spares

Dimensions & Weights

SIZE (inch)	WEIGHT (kg)	A (mm)	B (mm)	C (mm)
1/8	0.13	29	74	44
1/4	0.15	39	73	44
3/8	0.21	45	77	44
1/2	0.29	51	91	52
3/4	0.46	58	104	65

Dimensional Drawing

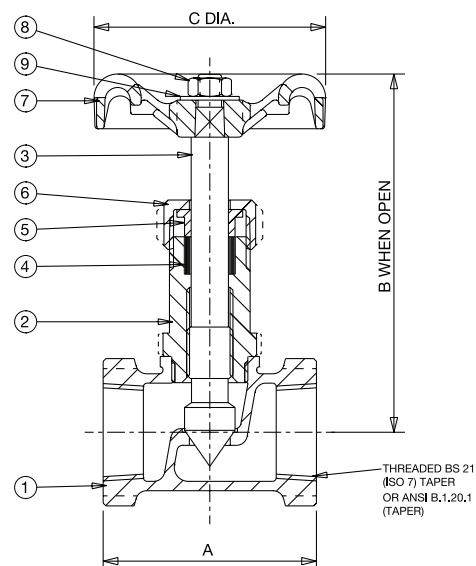

PRESSURE RATING: PN32
TEMPERATURE OPERATING RANGE: -10 to 100°C
END CONNECTION: Threaded BS 21 or ANSI B1.20.1

SPECIFICATION: Valve are manufactured in accordance with BS 5154 PN32 for Series B ratings. The needle disk is an integral part of the stem, and body seat is integral.

Valid as of 290719

Every effort has been made to ensure that the information contained in this publication is accurate at the time of publishing. Crane Ltd assumes no responsibility or liability for typographical errors or omissions or for any misinterpretation of the information within the publication and reserves the right to change without notice.

D72

Globe Valve

PN32

D72



Features & Benefits

- Crane bronze globe valves are highly efficient for throttling because seat and disc designs provide flow characteristics with proportionate relationships between valve lift and flow rate.

Materials

NO.	PART	MATERIAL	SIZES
1	Body	Bronze BS EN 1982 CC491K	-
2	Bonnet	Sil. Al. Bronze BS EN 12163 CW301G	1/8 - 3/8
2	Bonnet	Brass BS EN 12164 CW614N	3/4
3	Stem	Sil. Al. Bronze BS EN 12163 CW301G	-
4	Packing*	Asbestos Free	-
5	Gland	Brass BS EN 12164 CW614N	-
6	Packing Nut	Brass BS EN 12164 CW614N	-
7	Handwheel	Aluminium	-
8	Handwheel Nut	Brass BS EN 12164 CW614N	-
9	Identity Plate	Aluminium	-

*Recommended spares

Dimensions & Weights

SIZE (inch)	WEIGHT (kg)	A (mm)	B (mm)	C (mm)
1/8	0.13	29	74	44
1/4	0.15	39	73	44
3/8	0.21	45	77	44
1/2	0.29	51	91	52
3/4	0.46	58	104	65

Dimensional Drawing

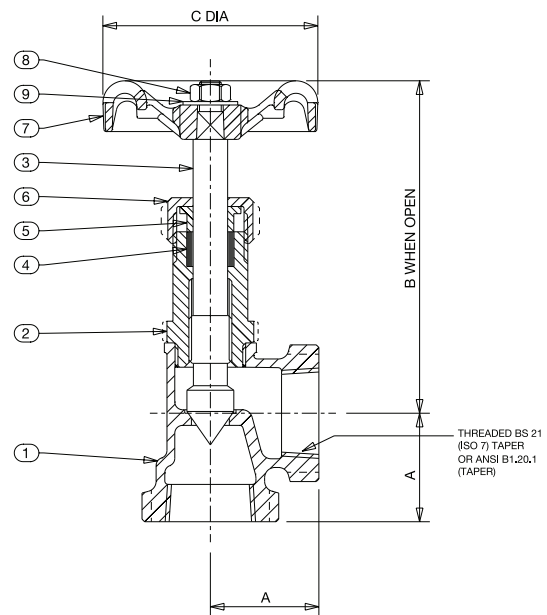

PRESSURE RATING: PN32

TEMPERATURE OPERATING RANGE: -10 to 100°C

END CONNECTION: Threaded BS 21 or ANSI B1.20.1

SPECIFICATION: Valve are manufactured in accordance with BS 5154 PN32 for Series B ratings. The needle disk is an integral part of the stem, and body seat is integral.

DM6

Bronze Globe Valve

PN16

DM6

Features & Benefits

- Crane bronze globe valves are highly efficient for throttling because seat and disc designs provide flow characteristics with proportionate relationships between valve lift and flow rate

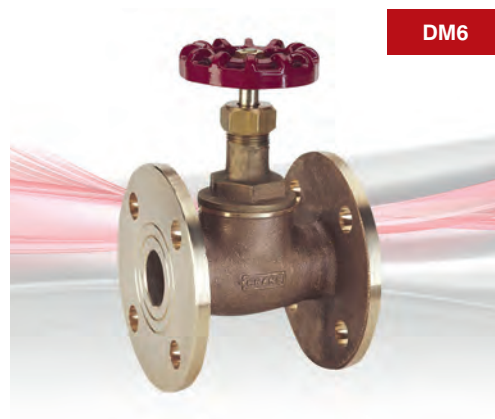

Materials

NO.	PART	MATERIAL	SIZES
1	Body	Bronze BS EN 1982 CC491K	All
2	Bonnet	Bronze BS EN 1982 CC491K	All
3	Stem	Brass BS EN 12163 CW721R	All
4	Disc	PTFE (25% Glass Filled)	All
5	Disc Holder	Bronze BS EN 1982 CC491K	All
6	Disc Stem Ring	Brass BS EN 12163 CW721R	All
7	Packing	Asbestos Free	All
8	Gland	Brass BS EN 12164 CW614N	All
9	Packing Nut	Brass BS EN 12164 CW614N	All
10	Washer	Brass BS EN 12164 CW614N	All
11	Disc Retaining Nut	Brass BS EN 12164 CW614N	All
12	Handwheel	Aluminium	All
13	Handwheel Nut	Brass BS EN 12164 CW614N	All
14	ID Plate	Aluminium	All

Dimensional Drawing

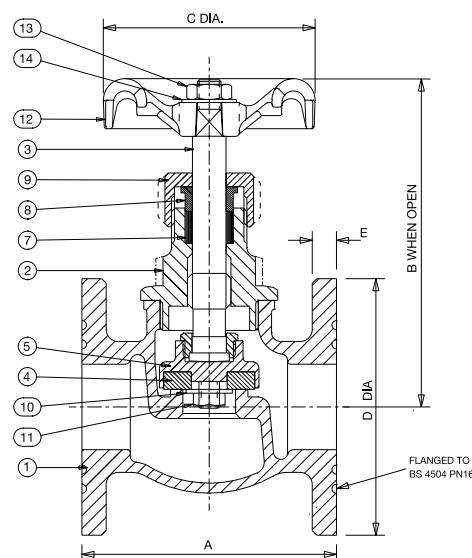

Dimensions & Weights

SIZE (mm)	WEIGHT (kg)	A (mm)	B (mm)	C (mm)	D (mm)	E (mm)
15	1.24	80	97	52	95	6
20	1.76	90	113	52	105	6
25	2.3	100	126	65	115	8
32	2.82	110	150	70	140	8
40	5.22	120	165	78	150	9
50	5.71	135	189	103	165	11

PRESSURE RATING: PN16

TEMPERATURE OPERATING RANGE: -10 to 170°C

UK END CONNECTION: Flanged BS 4504

US END CONNECTION: Not Specified

OPERATOR: Handwheel

AVAILABLE OPTOINS: P150 Locking Device

SPECIFICATION: Valves are manufactured in accordance with BS 5154 PN16 for Series B ratings, with 'short' face-to-face. Design incorporates disc holder retained on stem by a threaded ring. Body seat is integral of the semi-crown type.

End flanges conform to BS 4504 section 3.3 with flat face and are normally supplied drilled.

Note: Users attention is drawn to BS 4504 Section 3.3 clause 8 regarding types of gaskets and mating flanges to be used with metric flanged valves.

This valve is not suitable for use on Group 1 gases or unstable fluids, as defined by the Pressure Equipment Directive 2014/68/EU.*

* See page 155 for more information

Valid as of 290719

Every effort has been made to ensure that the information contained in this publication is accurate at the time of publishing. Crane Ltd assumes no responsibility or liability for typographical errors or omissions or for any misinterpretation of the information within the publication and reserves the right to change without notice.

DM11

Flanged Bronze Globe Valve

PN25

DM11

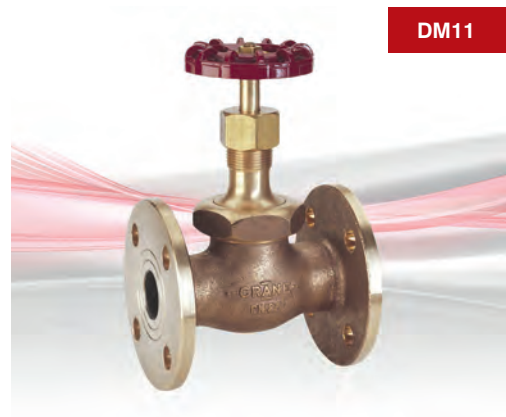

Features & Benefits

- Crane bronze globe valves are highly efficient for throttling because seat and disc designs provide flow characteristics with proportionate relationships between valve lift and flow rate

Materials

NO.	PART	MATERIAL	SIZES
1	Body	Bronze BS EN 1982 CC491K	All
2	Bonnet	Bronze BS EN 1982 CC491K	All
3	Stem	Bronze BS EN 1982 CC491K	All
4	Disc	PTFE (25% Glass Filled)	All
5	Disc Holder	Brass BS EN 12164 CW617N	15 - 25
5	Disc Holder	Bronze BS EN 1982 CC491K	32 - 80
6	Union Ring	Bronze BS EN 1982 CC491K	15 - 50
7	Packing	Asbestos Free	All
8	Gland	Brass BS EN 12164 CW614N	All
9	Packing Nut	Brass BS EN 12164 CW614N	15 - 40
9	Packing Nut	Bronze BS EN 1982 CC491K	50 - 80
10	Washer	Brass BS EN 12164 CW614N	15 - 50
11	Disc Ret'ng Nut	Brass BS EN 12164 CW614N	15 - 50
11	Disc Ret'ng Nut	Bronze BS EN 1982 CC491K	65 & 80
12	Handwheel	Aluminium	15 - 50
12	Handwheel	Malleable Iron BS EN 1562 GJMB-300-6	65 & 80
13	Handwheel Nut	Brass BS EN 12164 CW614N	All
14	ID Plate	Aluminium	All
15	Disc Stem Ring	Bronze BS EN 1982 CC491K	65 & 80
16	Bonnet Stud	Steel BS 970 070M20	65 & 80
17	Bonnet Stud Nut	Steel BS 4190 Gr.4	65 & 80
18	Gasket	Asbestos Free	65 & 80

Dimensional Drawing

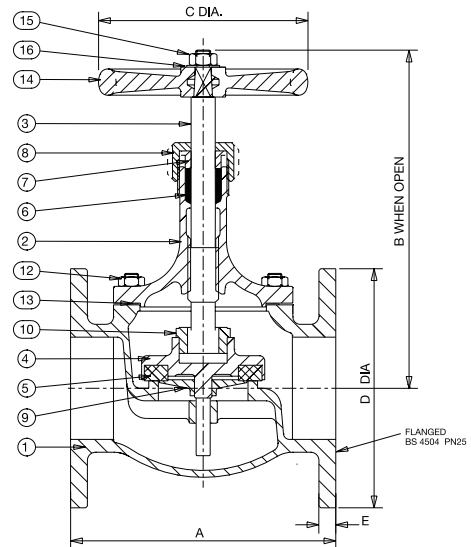

Dimensions & Weights

SIZE (mm)	WEIGHT (kg)	A (mm)	B (mm)	C (mm)	D (mm)	E (mm)
15	1.71	108	128	65	95	8
20	2.82	117	145	70	105	8
25	3.29	127	161	78	115	9
32	4.93	146	180	92	140	90
40	6.28	159	199	103	150	11
50	9.74	190	233	121	165	11
65	16.2	216	279	152	185	13
80	21.6	254	313	152	200	14

PRESSURE RATING: PN25

TEMPERATURE OPERATING RANGE: -10 to 186°C

UK END CONNECTION: Flanged BS 4504

US END CONNECTION: Not Specified

OPERATOR: Handwheel

AVAILABLE OPTOINS: P150 Locking Device

SPECIFICATION: Valves are manufactured in accordance with BS 5154 PN25 for series B ratings with 'long' face-to-face. Design incorporates disc holder which on sizes 15 to 50 slips on to stem and on sizes 65 and 80 is retained by a threaded ring. Body seat is integral of the semi-crown type. Sizes 15 to 50 have union bonnet; sizes 65 and 80 have a bolted bonnet.

End flanges conform to BS 4504 Section 3.3 with flat face and are normally supplied drilled.

Note: Users attention is drawn to BS 4504 Section 3.3 Clause 8 regarding types of gaskets and mating flanges to be used with metric flanged valves.

This valve is not suitable for use on group 1 gases or unstable fluids, as defined by the Pressure Equipment Directive 2014/68/EU.*

* See page 155 for more information

Valid as of 27/11/19

Every effort has been made to ensure that the information contained in this publication is accurate at the time of publishing. Crane Ltd assumes no responsibility or liability for typographical errors or omissions or for any misinterpretation of the information within the publication and reserves the right to change without notice.

F372

Cast Iron Globe Valve

Class 125

F372

Features & Benefits

- Crane cast iron globe valves are highly efficient for throttling because seat and disc designs provide flow characteristics with proportionate relationships between valve lift and flow rate



Materials

PART	MATERIAL	SIZES
Body	Cast Iron BS EN 1561 GJL-250	All
Bonnet	Cast Iron BS EN 1561 GJL-250	All
Disc Guide Pin	Brass BS EN 12164 CW721R	5 & 6
Gland	Brass BS EN 12164 CW614N	All
Gland Flange	Malleable Iron BS EN 1562 GJMB-300-6	All
Gasket	Asbestos Free	All
Disc Stem Ring	Brass BS EN 12164 CW721R	All
Lockwasher	Brass BS EN 1652	All
Disc	Bronze BS EN 1982 CC491K	All
Body Seat Ring	Bronze BS EN 1982 CC491K	All
Stem	Brass BS EN 12164 CW721R	All
Packing	Asbestos Free	All
Yoke Bushing	Brass BS EN 12164 CW721R	All
Handwheel	Malleable Iron BS EN 1562 GJMB-300-6	All

Dimensions & Weights

SIZE (inch)	WEIGHT (kg)	A (mm)	B (mm)	C (mm)	D (mm)	E (mm)	F (mm)
2	23.1	203	16	152	203	310	335
2 1/2	27.2	216	17	178	203	330	356
3	34.5	241	19	191	229	362	392
4	54.4	292	24	229	254	416	446
5	70.8	330	24	254	305	457	489
6	95.3	356	25	279	305	476	516

Dimensional Drawing

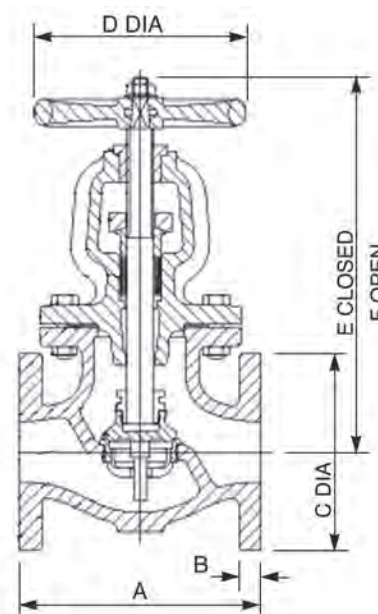

Pressure/Temperature Ratings

TEMPERATURE (°C)	-10 to 65	150	230
PRESSURE (BAR)	13.8	11.4	8.6

Intermediate pressure ratings shall be determined by interpolation.

PRESSURE RATING: Class 125

TEMPERATURE OPERATING RANGE: -10 to 230°C

US END CONNECTION: ANSI Class 125

OPERATOR: Handwheel

AVAILABLE OPTOINS: Flanges Undrilled

SPECIFICATION: Valves are manufactured in accordance with BS 5152: 1974 and also meet the requirements of MSS.SP-85: 2002.

End flanges conform to BS 1560 Section 3.2/ANSI B16.1 Class 125 with Flat Face and are normally supplied drilled.

Valves detailed on this page are dimensioned in metric terms.

This valve is not suitable for use on Group 1 gases or unstable fluids, as defined by the Pressure Equipment Directive 2014/68/EU.*

* See page 155 for more information

Valid as of 290719

Every effort has been made to ensure that the information contained in this publication is accurate at the time of publishing. Crane Ltd assumes no responsibility or liability for typographical errors or omissions or for any misinterpretation of the information within the publication and reserves the right to change without notice.

FM369

Cast Iron Globe Valve

PN16

FM369



Features & Benefits

- Crane cast iron globe valves are highly efficient for throttling because seat and disc designs provide flow characteristics with proportionate relationships between valve lift and flow rate

Materials

PART	MATERIAL	SIZES
Body	Cast Iron BS EN 1561 GJL-250	All
Bonnet	Cast Iron BS EN 1561 GJL-250	All
Disc Guide Pin	Brass BS EN 12164 CW721R	125 - 150
Gland	Brass BS EN 12164 CW614N	All
Gland Flange	Malleable Iron BS EN 1562 GJMB-300-6	All
Gasket	Asbestos Free	All
Disc Stem Ring	Brass BS EN 12164 CW721R	All
Lockwasher	Brass BS EN 1652	All
Disc	Bronze BS EN 1982 CC491K	All
Body Seat Ring	Bronze BS EN 1982 CC491K	All
Stem	Brass BS EN 12164 CW721R	All
Packing	Asbestos Free	All
Yoke Bushing	Brass BS EN 12164 CW721R	All
Handwheel	Malleable Iron BS EN 1562 GJMB-300-6	All

Dimensional Drawing

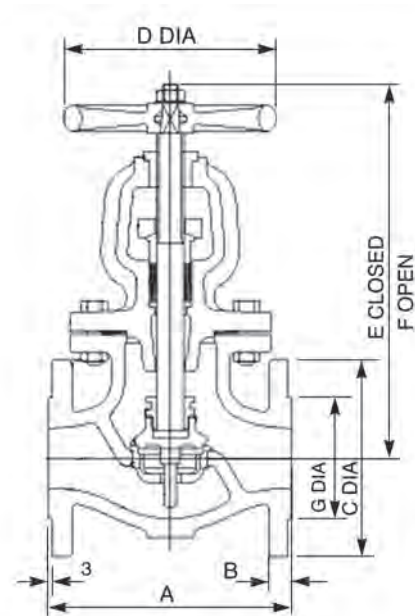

Dimensions & Weights

SIZE (mm)	WEIGHT (kg)	A (mm)	B (mm)	C (mm)	D (mm)	E (mm)	F (mm)	G (mm)
50	24.2	203	20	165	203	310	335	102
65	29	216	20	185	203	330	356	122
80	36.9	241	22	200	229	362	392	138
100	56	292	24	220	254	416	446	158
125	72.3	330	26	250	305	457	489	188
150	98.8	356	26	285	305	476	516	212

Pressure/Temperature Ratings

TEMPERATURE (°C)	-10 to 100	220
PRESSURE (BAR)	16	12.1

Intermediate pressure ratings shall be determined by interpolation.

PRESSURE RATING: PN16

TEMPERATURE OPERATING RANGE: -10 to 220°C

UK END CONNECTION: Flanged BS EN 1092-2 PN16

OPERATOR: Handwheel

AVAILABLE OPTOINS: Flanges Undrilled

SPECIFICATION: Valves are manufactured in accordance with BS EN 13789:2010.

End flanges conform to BS EN 1092-2 PN16 with raised face.

Valves are normally supplied drilled.

This valve is not suitable for use on group 1 gases or unstable fluids, as defined by the Pressure Equipment Directive 2014/68/EU.*

* See page 155 for more information

143XU

Cast Steel Globe Valve

Class 150

143XU



GENERAL VALVES

Features & Benefits

- Ideal for throttling service
- Flow characteristics permit accurate and repeatable flow control
- Seat ring is seal welded to eliminate leak paths
- Outside screw & yoke
- Bolted bonnet

Materials

PART	MATERIAL
Body	A216 WCB
Bonnet	A216 WCB
Seat Rings	Hardfaced
Disc	13% CR Overlay
Stem	410 SS
Packing	Graphite
Bonnet Gasket	Soft Iron
Back Seat	410 SS
Disc Stem Nut	410 SS
Disc Washer	Carbon Steel
Gland	410 SS
Gland Flange	WCB
Eye Bolt	Steel
Eye Bolt Nuts	A563 Gr. A or 0
Pins	-
Bonnet Studs	A193 Gr. B7
Bonnet Nuts	A194 Gr. 2H
Handwheel	WCB
Handwheel Nut	A194 Gr. 2H
ID Tags	SS
ID Pins	Steel

Dimensional Drawing

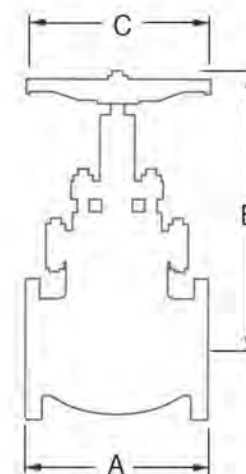

Dimensions & Weights

SIZE (inch)	WEIGHT (lbs)	A (inch)	B VALVE OPEN (inch)	C (inch)
2	53	8.00	14.00	8.00
2 1/2	70	8.50	15.00	8.00
3	90	9.50	17.00	10.00
4	143	11.50	20.00	12.00
6	246	16.50	24.00	16.00
8	392	19.50	25.00	16.00
10	605	24.50	29.00	20.00
12	900	27.50	38.00	20.00

Industry Standards

STEEL VALVES	ANSI B16.34
FACE-TO-FACE/END-TO-END	ANSI B16.10
FLANGE DIMENSIONS	ANSI B16.5
TESTING	API 598
ACCEPTANCE	API RP591

Intermediate pressure ratings shall be determined by interpolation.

SIZE RANGE: 2 - 12 inches **PRESSURE TEMPERATURE RATING:** Class 150

Carbon Steel
ASTM A216 Grade WCB
285 psi @ -20°F to 100°F

Valid as of 290719

Every effort has been made to ensure that the information contained in this publication is accurate at the time of publishing. Crane Ltd assumes no responsibility or liability for typographical errors or omissions or for any misinterpretation of the information within the publication and reserves the right to change without notice.

151XU

Cast Steel Globe Valve

Class 300

151XU

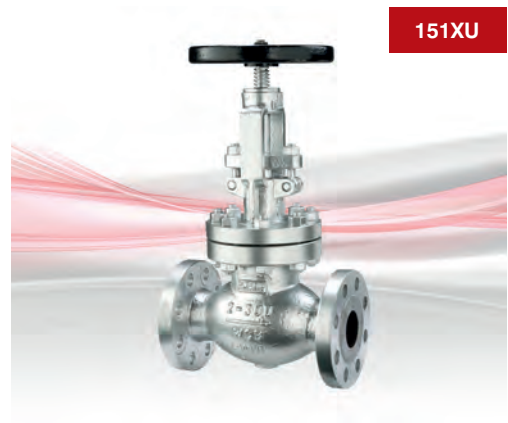

Features & Benefits

- Ideal for throttling service
- Flow characteristics permit accurate and repeatable flow control
- Seat ring is seal welded to eliminate leak paths
- Outside screw & yoke
- Bolted Bonnet

Materials

PART	MATERIAL
Body	A216 WCB
Bonnet	A216 WCB
Seat Rings	Hardfaced
Disc	13% CR Overlay
Stem	410 SS
Packing	Graphite
Bonnet Gasket	Spiral Wound
Back Seat	410 SS
Disc Stem Nut	410 SS
Disc Washer	Carbon Steel
Gland	410 SS
Gland Flange	WCB
Eye Bolt	Steel
Eye Bolt Nuts	A563 Gr. A or 0
Pins	-
Bonnet Studs	A193 Gr. B7
Bonnet Nuts	A194 Gr. 2H
Handwheel	WCB
Handwheel Nut	A194 Gr. 2H
ID Tags	SS
ID Pins	Steel

Dimensional Drawing

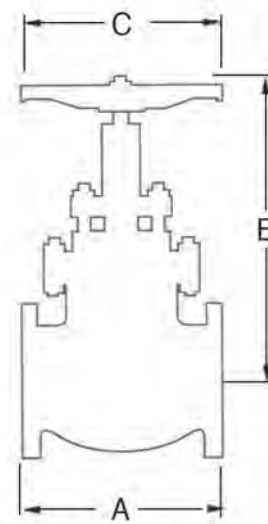

Dimensions & Weights

SIZE (inch)	WEIGHT (lbs)	A (inch)	B VALVE OPEN (inch)	C (inch)
2	75	10.50	16.75	8.00
2 1/2	99	11.50	18.00	10.00
3	132	12.50	21.00	10.00
4	209	14.00	23.00	14.00
6	440	17.50	36.00	18.00
8	693	22.00	39.00	24.00
10	1008	24.50	41.00	24.00
12	1100	28.00	48.00	24.00

Industry Standards

STEEL VALVES	ANSI B16.34
FACE-TO-FACE/END-TO-END	ANSI B16.10
FLANGE DIMENSIONS	ANSI B16.5
TESTING	API 598
ACCEPTANCE	API RP591

Intermediate pressure ratings shall be determined by interpolation.

SIZE RANGE: 2 - 12 inches **PRESSURE TEMPERATURE RATING:** Class 300

Carbon Steel
 ASTM A216 Grade WCB
 740 psi @ -20°F to 100°F

Valid as of 290719

Every effort has been made to ensure that the information contained in this publication is accurate at the time of publishing. Crane Ltd assumes no responsibility or liability for typographical errors or omissions or for any misinterpretation of the information within the publication and reserves the right to change without notice.

PROJECT

Phase III, The Avenues

Phase 3 of Kuwait's largest shopping destination was completed in 2012 and consists of more than 86,000 square metres of retail space. Located in the Al Rai district of Kuwait City, the mall has been designed by London and Los Angeles offices of Gensler, in conjunction with Kuwait developers, Mabaneer.

The completed third phase houses 545 retail units. This stage of the project was awarded to Bader Al Mulla, one of Kuwait's top MEP contractors on a very tight time-scale. Crane Fluid Systems together with their distributor, Asia Electro-Mechanical, committed to holding valve stocks in Kuwait to service this project and ensure no delays. This was a key factor in persuading Bader Al Mulla to place the order for the complete range of valves with Asia/Crane FS.

The first phase of the project opened in April 2007 and includes the largest IKEA in the region, the first Carrefour supermarket in Kuwait and a 10 screen cinema complex. The building design is inspired by the natural forms and elements of the desert. It is also built using environmentally friendly techniques which utilise natural sunlight.

The completed mall includes more than 100 restaurants, a spa, an entertainment centre, a boutique mall, hotels, offices, a convention centre and a theatre.

LOCATION:

Kuwait

DEVELOPERS:

Gensler (London & Los Angeles), Mabaneer Co.

CONTRACTOR:

Bader Al Mulla

DISTRIBUTOR:

Asia Electro-Mechanical

SPECIFICATION:

A wide range of traditional and commissioning valves



Radiator Valves

Series 3000 radiator valves from Crane Fluid System are recognised as the industry standard for high quality and dependable performance. The range incorporates Thermostatic, Wheelhead and Lockshield valves; and also a Universal valve body to accommodate TRV and Wheel heads. All valves are available in 1/2" and 3/4" BSP sizes, each supplied complete with complementary compression end adaptors. The chrome plated brass valves are complemented by a range of accessories including Remote Sensors and Transmitters, and Tamperproof TRV locks.

The Hattersley Series 3000 radiator valves enable isolation, regulation and give thermostatic control.

Universal Valve Body for TRV and Wheel Head

The range offers interchangeability of the TRV head and the Wheelhead. The revolutionary body design enables both the TRV head and the Wheelhead to be connected directly to a common valve body without the need for adaptors. This design breakthrough therefore reduces the cost of stock holding and increases the versatility of the range.

Function

Thermostatic valves are typically used for regulating the fluid flow to the radiators of central heating systems. They are provided with a regulating element which automatically controls the opening of the valve to keep the ambient temperature of the room, where they are installed, constant at the set value. This prevents unwanted temperature rises and achieves considerable energy savings.

The Series 3000 Radiator valve range is eminently suitable for building services installations where durability and rugged construction are predominant, while satisfying the aesthetic requirements demanded for modern commercial and domestic interiors.

Maximum working pressure: 10 bar operating between 5 to 100°C.

The CFS range of valves and TRV controls are approved to standards UNI EN 215.

Additional information available on request.



D885

Universal Valve Body for TRV and Wheel Head

The new range offers interchangeability of the TRV Head and the Wheel Head. The revolutionary body design enables both the TRV head and the Wheel Head to be connected directly to a common valve body without the need for adaptors. This design breakthrough reduces the cost of stock holding and increases the versatility of the range. The range has been consolidated into a single chrome plated finish.

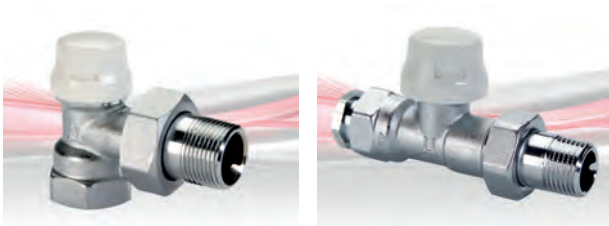

Function

Thermostatic valves are typically used for regulating the fluid flow to the radiators of central heating systems. They are provided with a regulating element which automatically controls the opening of the valve to keep the ambient temperature of the room constant at the set value. This prevents unwanted temperature rises and achieves considerable energy savings. The new Crane radiator valve range is eminently suitable for building services installations where durability and rugged construction are predominant, while satisfying the aesthetic requirements demanded for modern commercial and domestic interiors.

Materials

FIG. NO.	PART NO.	DESCRIPTION	SIZES
D885	OJG90832J	Angle Pattern TRV & Wheel Head Valve Body	1/2"
D885	OJG90833K	Angle Pattern TRV & Wheel Head Valve Body	3/4"
D886	OJG90834L	Straight Pattern TRV & Wheel Head Valve Body	1/2"
D886	OJG90835M	Straight Pattern TRV & Wheel Head Valve Body	3/4"
T80	OJG90848S	Wheel Head	-
T90	OJG90836N	TRV Head	-
T95	OJG90854Q	90° Elbow	-
T100	OJG90837P	Tamperproof Ring	-
D887	OJG90844N	Angle Pattern Lockshield Valve	1/2"
D887	OJG90854P	Angle Pattern Lockshield Valve	3/4"
D888	OJG90846Q	Straight Pattern Lockshield Valve	1/2"
D888	OJG90847R	Straight Pattern Lockshield Valve	3/4"
D889 RS2	OJG90838Q	Remote Sensing TRV Sensor	2m
D889 RS8	OJG90840J	Remote Sensing TRV Sensor	8m
D889 RT2	OJG90841K	Remote Adjusting TRV Transmitter	2m
D889 RT8	OJG90843M	Remote Adjusting TRV Transmitter	8m
T70	OJG90852N	Nut & Olive	1/2"
T70	OJG90853P	Nut & Olive	3/4"

Operating Principle of Thermostatic Control

The thermostatic valve control head is a proportional temperature regulator, consisting of bellows containing liquid. When the ambient temperature increases, the consequent build-up in pressure causes an expansion in volume in the bellows, which in turn, dilate. When the temperature falls the reverse takes place; the bellows contract due to the effect of the thrust generated by the return spring. The axial movement of the sensitive element is transmitted to the valve obturator through the connecting spindle, thus regulating the flow of liquid to the heat emitter.

Construction Details

The control spindle is stainless steel with an EPDM O-Ring double seal. This means that the upper part of the control device can be replaced even when the system is in operation. The obturator is shaped in such a way as to optimise the fluid-dynamic characteristics of the valve during the progressive opening and closing actions in thermostatic operation. The large passage between seat and obturator causes reduced pressure drops in manual use.

Technical Specification

Valve Bodies

Material
 Body: Brass (BS EN 12165 CW617N), chrome plated
 Valve spindle: Stainless Steel
 Hydraulic seats: EPDM
 Control knob/cap: ABS (RAL 9010)
 Fluid: Water, glycol solutions
 (Max percentage of glycol – 30%)

Max differential pressure
 with control fitted: 1 bar
 Max working pressure: 10 bar
 Temperature range: 5-100oC

TRV Head

The TRV head is liquid filled, offering speedier reaction to room temperature changes.
 The TRV head has full CEN approval and is marked accordingly.
 O-Ring seal for better water-tight seal/connection.
 Maximum working pressure: 10 bar operating between 5 and 100oC.

System Sizing

For correct system sizing, the valves are normally selected by identifying the pressure drop in accordance with the flow diagrams.

TRV Head with Remote Sensor

(Head – T90 and Remote Sensor – d889 RS)

Max isolating differential pressure 1 bar
 Temperature adjustment range 0 to 28°C
 Frost protection cut in 7°C
 Max ambient temperature 50°C

0	*	1	2	3	4	5
0°C	7°C	12°C	16°C	20°C	24°C	28°C

TRV Transmitter

(Remote Adjusting TRV Transmitter – d889 RT)

Max isolating differential pressure 1 bar
 Temperature adjustment range 0 to 28°C
 Frost protection cut in 6°C
 Max ambient temperature 50°C

0	*	1	2	3	4	5
0°C	6°C	12°C	16°C	20°C	24°C	28°C



Valid as of 29/07/19

Every effort has been made to ensure that the information contained in this publication is accurate at the time of publishing. Crane Ltd assumes no responsibility or liability for typographical errors or omissions or for any misinterpretation of the information within the publication and reserves the right to change without notice.

D885 & T80

Angle Body & Wheel Head Valve

PN10

D885 & T80



GENERAL VALVES

Materials

NO.	PART	MATERIAL
1	Body	Brass (Chrome Plated) BS EN 12164 CW617N
2	Valve Insert Assembly	EPDM Valve Disc
3	T80 Wheel Head	Thermoplastic ABS
4	Tailpiece Ring	Brass BS EN 12164 CW617N
5	Tailpiece	Brass BS EN 12164 CW617N
6	Compression Olive	Brass BS EN 12164 CW602N
7	Compression Adaptor	Brass BS EN 12164 CW614N
8	Hydraulic Seals	Rubber EPDM

Dimensional Drawing

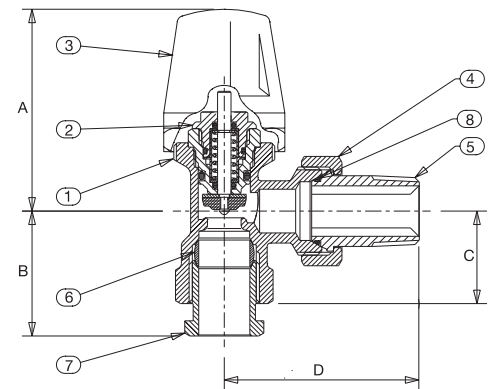

Dimensions & Weights

SIZE (mm)	WEIGHT (g)	A (mm)	B (mm)	C (mm)	D (mm)
15	350	60	37	27.5	58
22	519	61	42	30.5	66

D885 & T90

Angle Body & TRV Head

D885 & T90



Materials

NO.	PART	MATERIAL
1	Body	Brass (Chrome Plated) BS EN 12164 CW617N
2	Valve Insert Assembly	EPDM Valve Disc
3	T90 STD Thermostatic Head	Thermoplastic ABS
4	Tailpiece Ring	Brass BS EN 12164 CW617N
5	Tailpiece	Brass BS EN 12164 CW617N
6	Compression Olive	Brass BS EN 12164 CW602N
7	Compression Adaptor	Brass BS EN 12164 CW614N
8	Hydraulic Seals	Rubber EPDM

Dimensions & Weights

SIZE (mm)	WEIGHT (g)	A (mm)	B (mm)	C (mm)	D (mm)
15	350	96	37	27.5	58
22	519	98	42	30.5	66

Dimensional Drawing

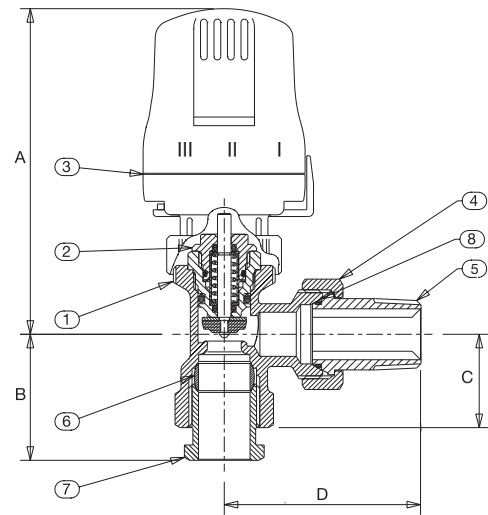

D885 with Thermostatic Control Head T90

Hydraulic Characteristics of Thermostatic Valves with Angle Connections

CODE	DESCRIPTION	SIZE	KV (m ³ /h) PROPORTIONAL BAND (K)					KVS
			1	1.5	2	3		
D885	Universal TRV/Wheel Valve Body	1/2"	0.34	0.52	0.64	0.90	2.39	
D885	Universal TRV/Wheel Valve Body	3/4"	0.40	0.63	0.81	1.09	3.19	
D887	Lockshield Valve	1/2"	0.34	0.52	0.64	0.90	2.39	
D887	Lockshield Valve	3/4"	0.40	0.63	0.81	1.09	3.19	

Kv = volume flow in m³/h producing pressure drop 1 bar

Kvs = Kv with valve fully open

CODE	DESCRIPTION	SIZE	NOMINAL FLOW (l/h)	MAX. DIFF PRES. (bar)
D885	Universal TRV/Wheel Valve Body	1/2"	180	1
D885	Universal TRV/Wheel Valve Body	3/4"	240	1
D887	Lockshield Valve	1/2"	180	1
D887	Lockshield Valve	3/4"	240	1

D886 & T80

Straight Body & Wheel Head Valve

D886 & T80

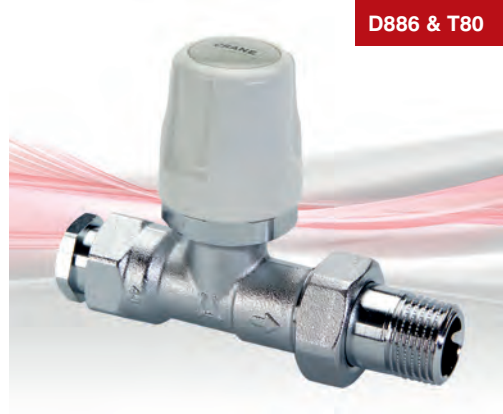

Materials

NO.	PART	MATERIAL
1	Body	Brass (Chrome Plated) BS EN 12164 CW617N
2	Valve Insert Assembly	EPDM Valve Disc
3	T80 Wheel Head	Thermoplastic ABS
4	Tailpiece Ring	Brass BS EN 12164 CW617N
5	Tailpiece	Brass BS EN 12164 CW617N
6	Compression Olive	Brass BS EN 12164 CW602N
7	Compression Adaptor	Brass BS EN 12164 CW614N
8	Hydraulic Seals	Rubber EPDM

Dimensions & Weights

SIZE (mm)	WEIGHT (g)	A (mm)	B (mm)	C (mm)	D (mm)
15	391	64	34	44	60
22	580	64	40	51	65

Dimensional Drawing

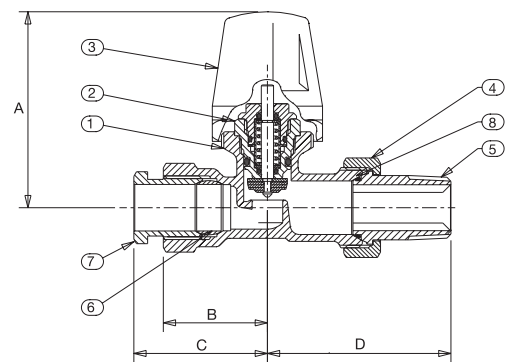

D886 & T90

Straight Body & TRV Head

D886 & T90

Materials

NO.	PART	MATERIAL
1	Body	Brass (Chrome Plated) BS EN 12164 CW617N
2	Valve Insert Assembly	EPDM Valve Disc
3	T90 STD Thermostatic Head	Thermoplastic ABS
4	Tailpiece Ring	Brass BS EN 12164 CW617N
5	Tailpiece	Brass BS EN 12164 CW617N
6	Compression Olive	Brass BS EN 12164 CW602N
7	Compression Adaptor	Brass BS EN 12164 CW614N
8	Hydraulic Seals	Rubber EPDM



GENERAL VALVES

Dimensions & Weights

SIZE (mm)	WEIGHT (g)	A (mm)	B (mm)	C (mm)	D (mm)
15	391	100	34	44	60
22	580	100	40	51	65

Dimensional Drawing

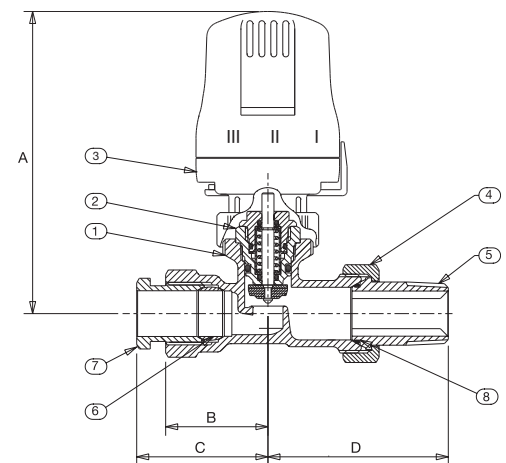

D886 with Thermostatic Control Head T90

Hydraulic Characteristics of Thermostatic Valves with Straight Connections

D886



CODE	DESCRIPTION	SIZE	KV (m ³ /h) PROPORTIONAL BAND (K)				
			1	1.5	2	3	KVS
D886	Universal TRV/Wheel Valve Body	1/2"	0.32	0.50	0.67	0.86	1.52
D886	Universal TRV/Wheel Valve Body	3/4"	0.43	0.63	0.82	1.05	2.20
D888	Lockshield Valve	1/2"	0.32	0.50	0.67	0.86	1.52
D888	Lockshield Valve	3/4"	0.43	0.63	0.82	1.05	2.20

Kv = volume flow in m³/h producing pressure drop 1 bar

Kvs = Kv with valve fully open

CODE	DESCRIPTION	SIZE	NOMINAL FLOW (l/h)	MAX. DIFF PRES. (bar)
D886	Universal TRV/Wheel Valve Body	1/2"	180	1
D886	Universal TRV/Wheel Valve Body	3/4"	240	1
D888	Lockshield Valve	1/2"	180	1
D888	Lockshield Valve	3/4"	240	1

D887

Angle Lockshield Valve

D887

GENERAL VALVES

Materials

NO.	PART	MATERIAL
1	Body	Brass (Chrome Plated) BS EN 12164 CW617N
2	Lockshield Assembly	Brass BS EN 12164 CW614N
3	Lockshield Cap	Thermoplastic ABS
4	Tailpiece Ring	Brass BS EN 12164 CW617N
5	Tailpiece	Brass BS EN 12164 CW617N
6	Compression Olive	Brass BS EN 12164 CW602N
7	Compression Adaptor	Brass BS EN 12164 CW614N
8	Hydraulic Seals	Rubber EPDM

**Dimensions & Weights**

SIZE (mm)	WEIGHT (g)	A (mm)	B (mm)	C (mm)	D (mm)
15	232	38.5	36.5	27.5	58
22	387	39.5	40.5	30.5	66

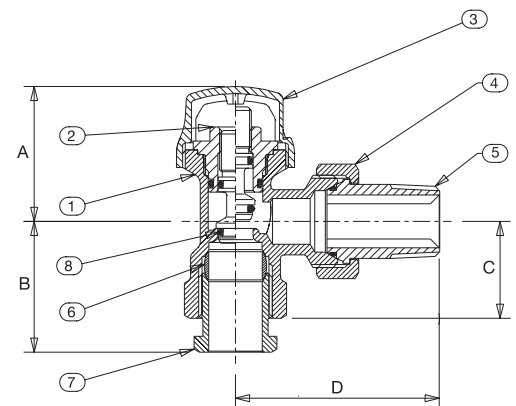
Dimensional Drawing

D888

Straight Lockshield Valve

D888



Materials

NO.	PART	MATERIAL
1	Body	Brass (Chrome Plated) BS EN 12164 CW617N
2	Lockshield Assembly	Brass BS EN 12164 CW614N
3	Lockshield Cap	Thermoplastic ABS
4	Tailpiece Ring	Brass BS EN 12164 CW617N
5	Tailpiece	Brass BS EN 12164 CW617N
6	Compression Olive	Brass BS EN 12164 CW602N
7	Compression Adaptor	Brass BS EN 12164 CW614N
8	Hydraulic Seals	Rubber EPDM

Dimensional Drawing

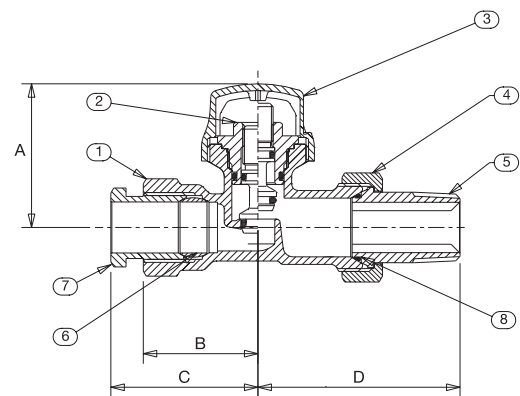

Dimensions & Weights

SIZE (mm)	WEIGHT (g)	A (mm)	B (mm)	C (mm)	D (mm)
15	273	43	34	44	60
22	455	44	40	51	65

Hydraulic Characteristics

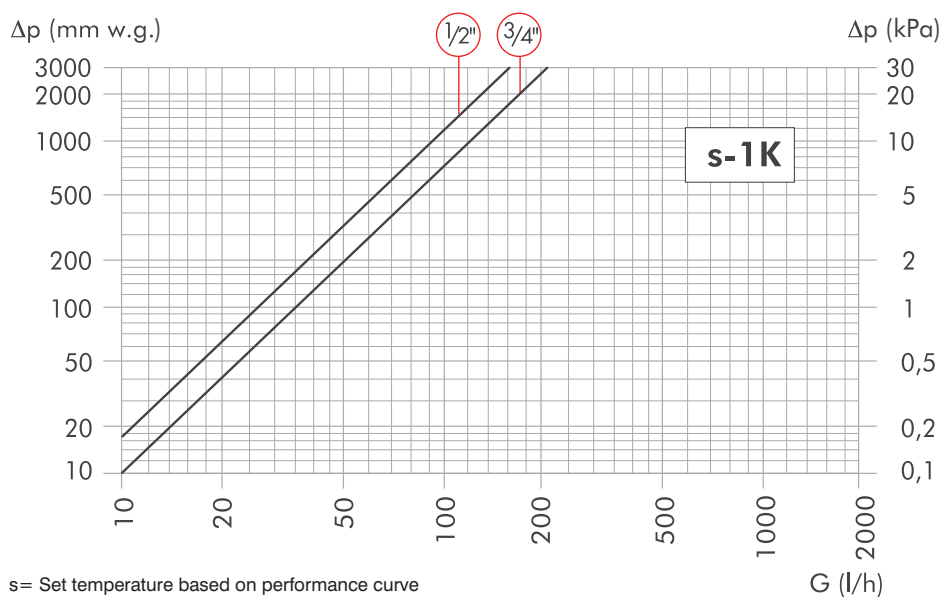

s = Set temperature based on performance curve
 1K = Less 1 deg Kelvin from set point
 2K = Less 2 deg Kelvin from set point

Valid as of 290719

Every effort has been made to ensure that the information contained in this publication is accurate at the time of publishing. Crane Ltd assumes no responsibility or liability for typographical errors or omissions or for any misinterpretation of the information within the publication and reserves the right to change without notice.

PROJECT

Steigenberger Hotel Tahrir Square, Cairo

The new Steigenberger Hotel El Tahrir is located in the heart of Cairo down town, within a short walking distance of the Egyptian Museum, Khan El Khalili and the Arab League.

The hotel offers 295 modernly furnished rooms and suites and on-site parking facilities. Meeting rooms are efficiently spread over one floor with a main multi-purpose hall able to take up to 300 guests.



LOCATION:

Cairo, Egypt

CHANNEL PARTNER:

OMEGA Engineering

CLIENT:

Steigenberger Hotels

SPECIFICATION:

Crane FS Balancing Valves and a wide selection of General Valves and Strainers.

CONSULTANT:

EHAF

CONTRACTOR:

Siemens



PROJECT

Tate Modern Project

Crane Fluid Systems has supplied Dominators and a selection of general valves to the new extension at the Tate Modern, The Tate Project, situated on the banks of the River Thames, South-East London.

Tate Modern was designed for an annual audience of two million visitors, but receives around five million, putting pressure on existing facilities. The expansion has created a less congested, more welcoming environment, at the same time doubling exhibition and display space and enabling the gallery to show more of their Collection. There are also more cafes, terraces and concourses in which to meet and unwind.

The new development has continued to bolster the growth of the borough. A public walkway through the building will make possible a direct route from the City to the heart of Southwark and there will be two new public squares to the south and west of the building. To the east, a new planted area has been created especially for the use of the local community and staff.

LOCATION:

London

CLIENT:

Tate

MAIN**CONTRACTOR:**

Mercury

DISTRIBUTOR:

BSS

ARCHITECT:

Herzog & de Meuron

SPECIFICATION:

Dominator and general valves

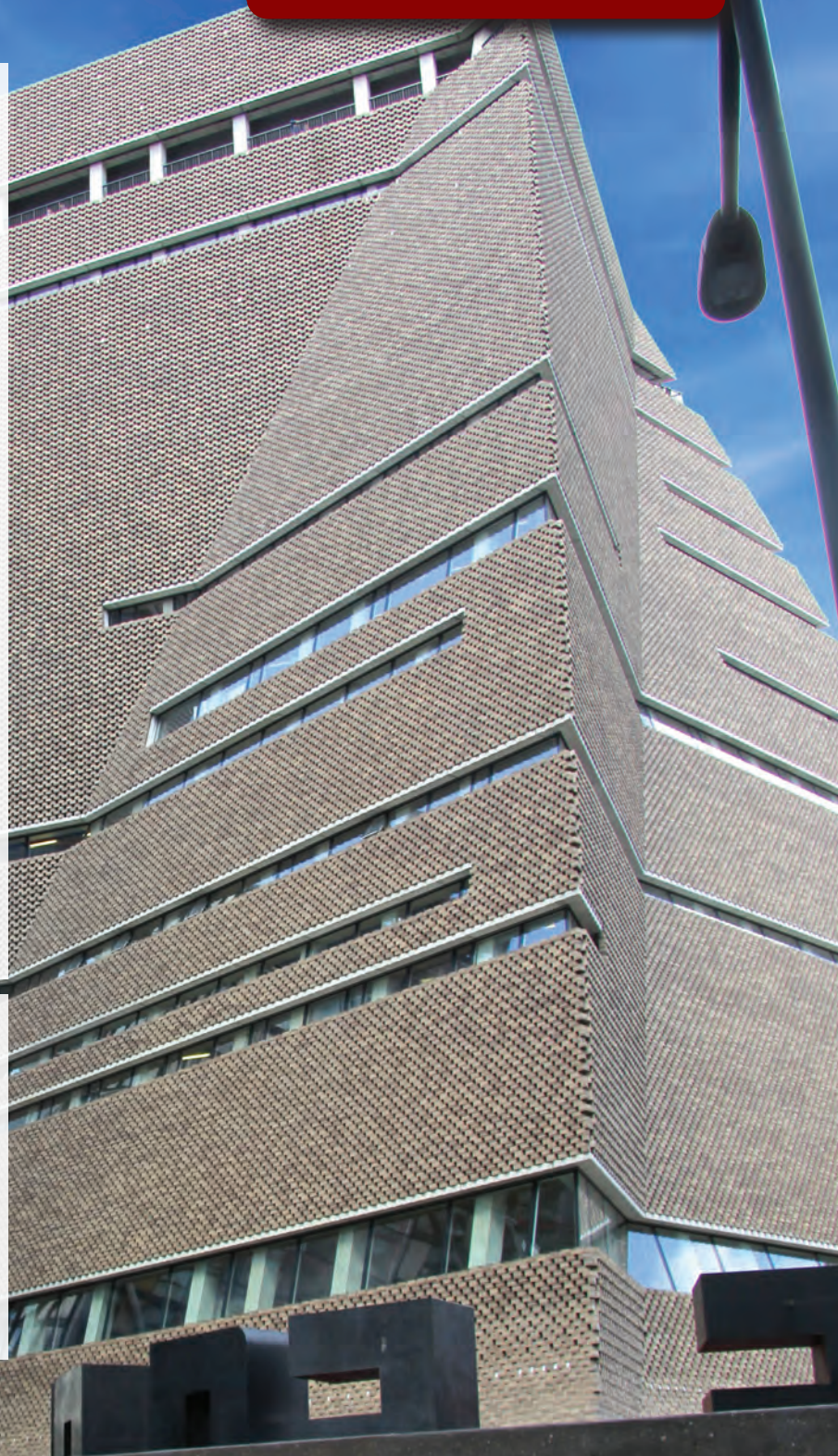

Strainers

Scale and dirt in piping systems can cause endless trouble and serious damage to pipeline equipment. Installation of Hattersley strainers will help eliminate the problems caused by foreign matter within piping systems. Generous proportions of Hattersley strainers allow the units to collect significant quantities of foreign matter before pressure losses necessitate cleaning of the basket.



D298

Fig. No.	PN Rating	End Connections	Size Range	Strainer Screen Material	Screen Hole Size	Free Flow %	Body Material	Fig.631 Test Points
D297†	32	Threaded	1/2 - 2"	Stainless Steel	0.75mm	23%	Bronze	No
D298†	16	Threaded	1/2 - 2"	Stainless Steel	"0.75mm (1/2 - 1") 1.4mm (1 1/4 - 2")"	"50% (1/2 - 1") 46% (1 1/4 - 2")"	Bronze	No
FM276	16	Flanged	50 - 200mm	Stainless Steel	1.5mm	32%	Ductile Iron	No
F277	Class 125	Flanged	50 - 200mm	Stainless Steel	1.5mm	32%	Ductile Iron	No
FM276	16	Flanged	250 - 600mm	Stainless Steel	1.5mm	32%	Ductile Iron	Yes
F277	Class 125	Flanged	250 - 300mm	Stainless Steel	1.5mm	32%	Ductile Iron	No
910	16	Flanged	350 - 600mm	Stainless Steel	3.0mm	40%	"Cast Iron (350 - 400mm) Ductile Iron (450 - 600mm)"	Yes
FM278	25	Flanged	50 - 300mm	Stainless Steel	1.5mm	32%	Ductile Iron	No
FM276W†	16	Flanged	65 - 150mm	Stainless Steel	1.5mm	32%	Cast Iron	No
FM278W†	25	Flanged	65 - 150mm	Stainless Steel	1.5mm	32%	Ductile Iron	No

† WRAS approved product

D297

Strainer



PN32

D297

GENERAL VALVES

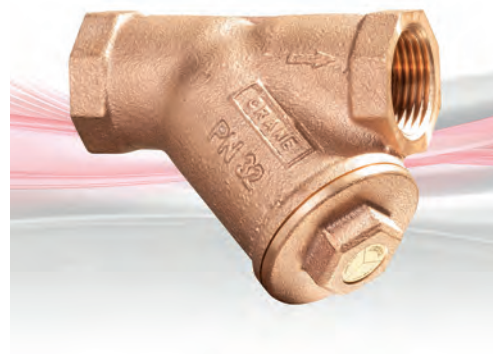

Features & Benefits

- Eliminate the problems caused by foreign matter within piping systems
- Perforated stainless steel screen with robust design, low flow resistance and high quality materials
- WRAS approved for use on hot and cold water systems up to 85°C
- 0.75mm screen perforations

Materials

PART	MATERIAL	SPECIFICATION
Body	Bronze	BS EN 1982 CC491K
Cap	Bronze	BS EN 1982 CC491K
Strainer Mesh	Stainless Steel	Type 304
Gasket	Klingsil	C4430
ID Plate	Anodised Aluminium	

Dimensional Drawing

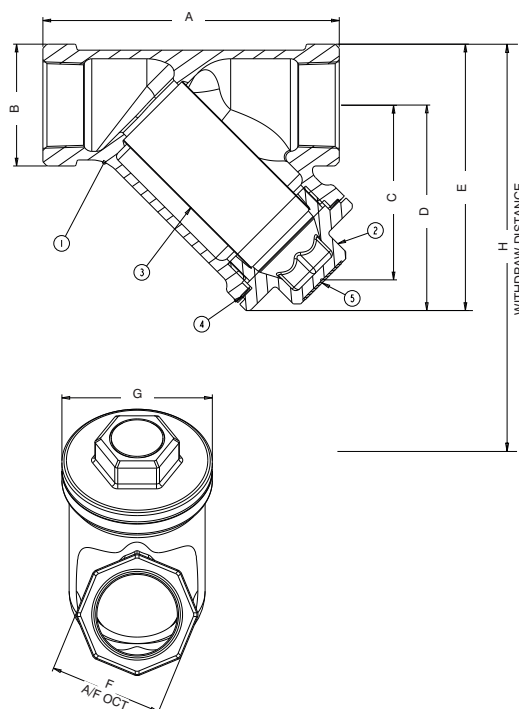

Dimensions & Weights

SIZE (inch)	A (mm)	B (mm)	C (mm)	D (mm)	E (mm)	F (mm)	G (mm)	H (Rc)	Kv	WEIGHT (kg)
1/2	71	29	42	49	63	27	35	144	4.4	0.27
3/4	86	35	51	60	77	33	44	176	9.5	0.44
1	101	45	55	67	90	42	54	202	16.5	0.78
1 1/4	134	54	80	93	120	50	63	294	24.5	1.30
1 1/2	148	63	87	103	134	58	73	322	30.8	1.81
2	176	77	98	119	157	71	93	367	55.6	3.10

Pressure/Temperature Ratings

TEMPERATURE (°C)	-10 to 100	130	15	180	200
PRESSURE (BAR)	32	26.5	22.8	17.4	14

Intermediate pressure ratings shall be determined by interpolation.

PRESSURE RATING: PN32

TEMPERATURE OPERATING RANGE: -10 to 200°C

UK END CONNECTION: Taper threaded to BS EN 10226-2

US END CONNECTION: ANSI B1.20.1

SPECIFICATION: Strainers fitted with stainless steel perforated strainer element with 0.75mm diameter holes. Screens fitted into Crane Strainers conform to the high standards of materials and workmanship associated with all Crane products.

This strainer is not suitable for use on Group 1 gases, Group 2 gases or unstable fluids, as defined by the Pressure Equipment Directive 2014/68/EU.*

Valid as of 290719

Every effort has been made to ensure that the information contained in this publication is accurate at the time of publishing. Crane Ltd assumes no responsibility or liability for typographical errors or omissions or for any misinterpretation of the information within the publication and reserves the right to change without notice.

D298

Bronze Strainer



PN16

D298



Features & Benefits

- A generous use of pipeline strainers will make a significant contribution to the reliability of a piping system and to optimise performance of the equipment - pumps, valves, flow measuring devices, traps etc
- Strainers are a low cost investment for any piping system and result in reduced maintenance costs as well as minimising 'downtime' by protecting the circuit from damage by foreign matter

Materials

NO.	PART	MATERIAL
1	Body	Bronze to BS EN 1982 CC491K
2	Mesh	Stainless Steel to A.I.S.I. Type 304
3	Cap Seal	PTFE
4	Cap	Bronze to BS EN 1982 CC491K
5	ID Plate	Aluminium

Dimensions & Weights

DN	MESH HOLE Ø (mm)	A (mm)	B (mm)	C (mm)	D (mm)	E (mm)	F (mm)	WEIGHT (kg)
15	0.75	58	33	40	55	62	27	0.16
20	0.75	70	42	54	69	80	33	0.28
25	0.75	88	48	60	80	93	39	0.38
32	1.4	96	55	69	95	108	49	0.64
40	1.4	107	61	76	107	118	55	0.88
50	1.4	126	79	99	135	153	67	1.40

Dimensional Drawing

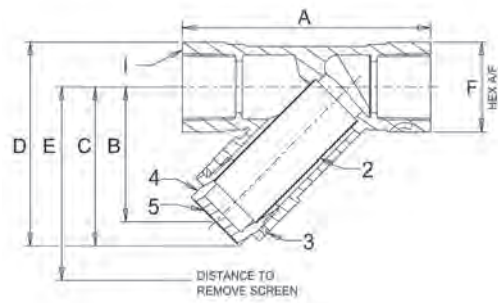

E = withdrawal distance for the screen

Pressure/Temperature Ratings

TEMPERATURE (°C)	-10 to 100	170
PRESSURE (BAR)	16	7

Intermediate pressure ratings shall be determined by interpolation.

WRAS approval -10 to 85°C

PRESSURE RATING: PN16

16 bar -10° to 100°C (max)*

7 bar at 170°C

TEST PRESSURE: 24 bar hydraulic

SPECIFICATION: Bronze body. Screen 304 stainless steel.

End connections threaded to BS EN 10266 (BS 21 Taper ISO R7) & B1.20.1 ANSI.

* WRAS -10 to 85°C

Every effort has been made to ensure that the information contained in this publication is accurate at the time of publishing. Crane Ltd assumes no responsibility or liability for typographical errors or omissions or for any misinterpretation of the information within the publication and reserves the right to change without notice.

FM276 - PN16

F277 - CLASS 125

Ductile Iron Strainer DN50 - DN200

Features & Benefits

- Scale and dirt in piping systems causes endless trouble and frequently serious damage to pipeline equipment.
- Installation of Crane strainers will help eliminate the problems caused by foreign matter within piping systems
- The FM276 offers the integrity of manufacture, quality and reliability which are the hallmarks of all Crane products
- Cap tapped and plugged for drain
- Stainless steel strainer element

Materials

PART	MATERIAL
Body	Ductile Iron BS EN 1563 EN-GJS-450-10
Cap	Ductile Iron BS EN 1563 EN-GJS-450-10
Gasket	Asbestos Free
Screen	Stainless Steel AISI Type 304
Drain Plug	Malleable Iron
Test Point Plug Rc 1/4	Malleable Iron
Studs	Cast Iron
Bolts	Ductile Iron
Bolts	Cast Iron

Dimensions & Weights

SIZE (mm)	WEIGHT (kg)	A (mm)	B (mm)	C (mm)	H (Rc)	kV
50	10	230	139.2	197	½"	58
65	14	290	158.6	227	1"	89
80	18	310	177.5	256	1"	127
100	24	350	197.6	293	1½"	180
125	37	400	269.6	362	2"	268
150	50	480	296.8	407	2"	356
200	89	600	363.4	513	2"	630



GENERAL VALVES

Dimensional Drawing

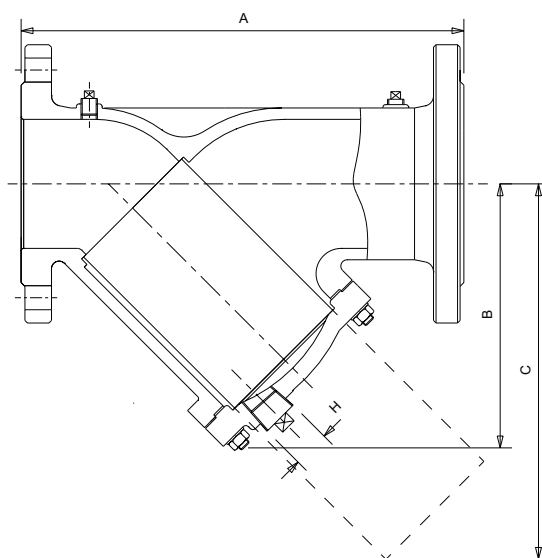

Pressure/Temperature Ratings - FM276

TEMPERATURE (°C)	-10 to 120	200
PRESSURE (BAR)	16	12.8

Pressure/Temperature Ratings - F277

TEMPERATURE (°C)	-10 to 65	230
PRESSURE (BAR)	13.8	8.6

Intermediate pressure ratings shall be determined by interpolation.

PRESSURE RATING: FM276: PN16 / F277: Class 125

TEMPERATURE OPERATING RANGE:

FM276: -10 to 200°C

F277: -10 to 230°C

UK END CONNECTION: Flanged BS EN 1092-2: PN16 Raised face

US END CONNECTION: Flanged Class 125 BS1560

- Section 3.2/ ANSI B16.1 Flat Face

SPECIFICATION:

Strainers are supplied with a stainless steel perforated strainer element. The mesh screen diameter hole sizes are as follows: DN50 - DN200 1.5mm diameter.

This product is suitable for use on Group 2 liquids only, as defined

by the Pressure Equipment Directive 2014/68/EU – Article 13.*

Bosses drilled, tapped and plugged.

* See page 155 for more information

Valid as of 290719

Every effort has been made to ensure that the information contained in this publication is accurate at the time of publishing. Crane Ltd assumes no responsibility or liability for typographical errors or omissions or for any misinterpretation of the information within the publication and reserves the right to change without notice.

FM276 DN250 - DN600 PN16

F277 DN250 - DN300 Class 125

Ductile Iron Strainer



FM276

Features & Benefits

- Scale and dirt in piping systems causes endless trouble and frequently serious damage to pipeline equipment.
- Installation of Crane strainers will help eliminate the problems caused by foreign matter within piping systems
- The FM276 offers the integrity of manufacture, quality and reliability which are the hallmarks of all Crane products
- Cap tapped and plugged for drain
- Stainless Steel strainer element

Materials

PART	MATERIAL	SIZE
Body	Ductile Iron A536 65-45-12 (EN-GJS-450-10)	250-500
Body	Ductile Iron BS EN 1563 (EN-GJS-500-7)	600
Cap	Ductile Iron A536 65-45-12 (EN-GJS-450-10)	250-500
Cap	Ductile Iron BS EN 1563 (EN-GJS-500-7)	600
Gasket	Asbestos Free	All
Screen	Stainless Steel AISI Type 304	All
Drain Plug	Malleable Iron	All
Test Point Plug Rc 1/4	Malleable Iron	All
Studs	Steel Grade 8.8	250-300
Nuts	Steel Grade 8	250-300
Bolts	Carbon Steel Grade 4.6	350-500
Bolts	Carbon Steel Grade 4.8	600

Dimensional Drawing

Drawing depicts to sizes DN350-600 with bolts

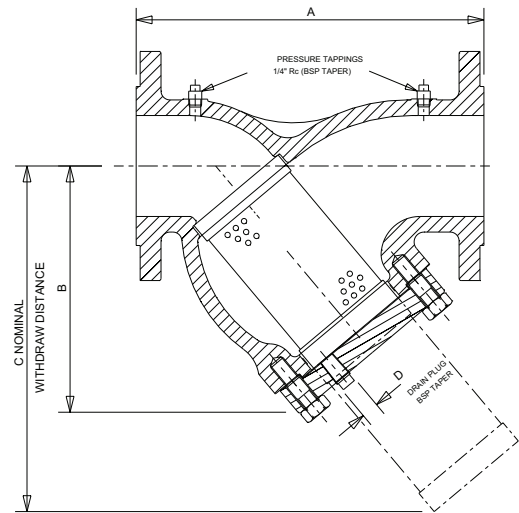

Dimensions & Weights

SIZE (mm)	WEIGHT (kg)	A (mm)	B (mm)	C (mm)	D (Rc)	kV
250	266	686	534	788	2"	1470
300	397	757	624	928	2"	2151
350	328	848	680	1015	2"	3018
400	452	984	765	1135	2"	4138
450	627	1105	845	1250	2"	5233
500	751	1257	997	1605	2"	6810
600	1080	1450	1160	1655	2"	8180

Pressure/Temperature Ratings - FM276

TEMPERATURE (°C)	-10 to 120	200
PRESSURE (BAR)	16	12.8

- F277

TEMPERATURE (°C)	-10 to 65	230
PRESSURE (BAR)	13.8	8.6

Intermediate pressure ratings shall be determined by interpolation.

PRESSURE RATING: FM276: PN16 / F277: Class 125

TEMPERATURE OPERATING RANGE:

FM276: -10 to 200°C

F277: -10 to 230°C

UK END CONNECTION: Flanged BS EN 1092-2: PN16

US END CONNECTION: Flanged Class 125 BS1560

- section 3.2 / ANSI B16.1 Flat Face

SPECIFICATION:

Strainers are supplied with a stainless steel perforated strainer element. The mesh screen diameter hole sizes are as follows: DN250 - DN300 1.5mm diameter, DN350-DN500 3.2mm diameter and DN600 3.0mm diameter.

This product is suitable for use on Group 2 liquids only, as defined by the Pressure Equipment Directive 2014/68/EU – Article 13.*

Bosses drilled, tapped and plugged.

* See page 155 for more information

Valid as of 290719

Every effort has been made to ensure that the information contained in this publication is accurate at the time of publishing. Crane Ltd assumes no responsibility or liability for typographical errors or omissions or for any misinterpretation of the information within the publication and reserves the right to change without notice.

FM278

Ductile Iron Strainer

PN25

Features & Benefits

- Scale and dirt in piping systems causes endless trouble and frequent serious damage to pipeline equipment
- Installation of Crane strainers will help eliminate the problems caused by foreign matter with piping systems
- The FM278 offers the integrity of manufacture, quality and reliability which are the hallmarks of Crane products
- Cap tapped and plugged for drain (drain valve sold separately)



GENERAL VALVES

Materials

NO.	PART	MATERIAL
1	Body	Ductile Iron - BS EN 1563 EN GJS 500/7
2	Cap	Ductile Iron - BS EN 1563 EN GJS 500/7
3	Gasket	Asbestos Free
4	Plug	Ductile Iron - BS EN 1563 EN GJS 500/7
5	Screen	304 Stainless Steel

Dimensions & Weights

SIZE (mm)	A (mm)	B (mm)	H(RC)	WEIGHT (kg)
50	230	146	½"	13.0
65	273	174	1"	18.3
80	295	198	1"	21.2
100	352	232	1"	25.9
125	416	285	1¼"	36.0
150	470	305	1½"	60.0
200	543	401	1½"	100.0
250	660	473	2"	170.0
300	770	554	2"	290.0

Dimensional Drawing

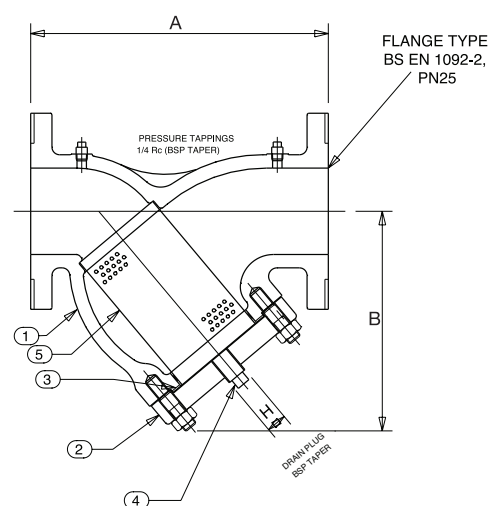

Pressure/Temperature Ratings

TEMPERATURE (°C)	-10 to 120
PRESSURE (BAR)	25

Intermediate pressure ratings shall be determined by interpolation.

PRESSURE RATING: PN16

END CONNECTION: Flanged to BS EN 1092-2 PN25

SPECIFICATION: Flanges conform to BS EN 1092-2 PN25 Section 3.2 table 11 with raised face.

Strainers are supplied with a stainless steel perforated strainer element having 1.6mm diameter holes.

This product is suitable for use on Group 2 liquids only, as defined by the Pressure Equipment Directive 2014/68/EU.*

* See page 155 for more information

FM278W

Strainer



PN25

FM278W



Features & Benefits

- Crane strainers will help eliminate the problems caused by foreign matter within piping systems
- WRAS approved range from DN65 to DN150
- WRAS approved for use with wholesome (potable) water
- WRAS approved internal epoxy powder coating

Materials

PART	MATERIAL	SPECIFICATION
Body	Ductile Iron	BS EN 1563 EN GJS 500/7
Cap	Ductile Iron	BS EN 1563 EN GJS 500/7
Gasket	Asbestos Free	
Stud	Steel	BS 4439 GRADE 8.8
Nut	Steel	BS 3692 GRADE 8
Screen Hole Size Ø1.5mm 32% Open Ratio	Stainless Steel	Type 304
Drain Plug	Malleable Iron	
Test Point Plug Rc 1/4	Malleable Iron	

Dimensions & Weights

SIZE (DN)	A (mm)	B (mm)	C (mm)	D (mm)	E (mm)	F (mm)	G (mm)	H (Rc)	WEIGHT (kg)
65	185	19	118	3	273	210	298	1 1/4"	18
80	200	19	132	3	295	215	301	1 1/4"	21
100	235	19	156	3	252	245	350	1 1/4"	32
125	270	19	184	3	412	297	430	1 1/2"	46
150	300	20	211	3	470	333	484	1 1/2"	62

Dimensional Drawing

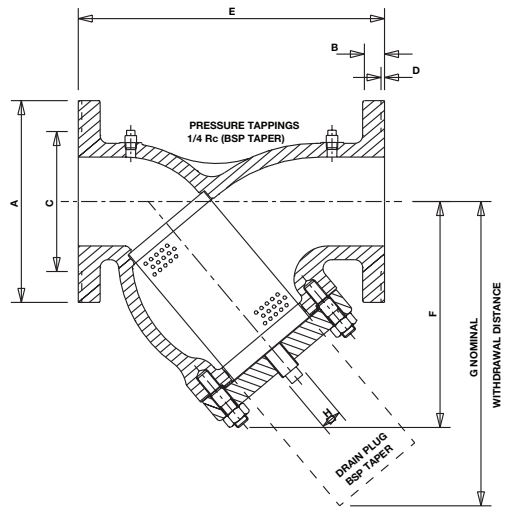

Pressure/Temperature Ratings

TEMPERATURE (°C)	-10 to 85
PRESSURE (BAR)	25

Intermediate pressure ratings shall be determined by interpolation.

END CONNECTION: Flanged to BS EN 1092-2 PN25

SPECIFICATION: Flanges conform to BS EN 1092-2 PN25 Section 3.2 table 11 with raised face.

Strainers are supplied with a stainless steel perforated strainer element having 1.6mm diameter holes.

This product is suitable for use on Group 2 liquids only, as defined by the Pressure Equipment Directive 2014/68/EU.*

* See page 155 for more information

Valid as of 290719

Every effort has been made to ensure that the information contained in this publication is accurate at the time of publishing. Crane Ltd assumes no responsibility or liability for typographical errors or omissions or for any misinterpretation of the information within the publication and reserves the right to change without notice.

PROJECT

HSBC Data Centre

This HSBC Data Centre is the first standalone data centre in Hong Kong meeting the design requirements of Tier IV standard.

The centre is recognised by the global IT industry for the high levels of reliability and accessibility of its on-site infrastructure, building support services, security and computer layout designs. The project site area is approximately 48,000 sq m, with a corresponding gross floor area of about 57,200 sq m.

The data centre operates uninterrupted 24 hours per day, 365 days per year, to meet current and foreseeable future business needs for more than 20 countries and 60 locations.

LOCATION:

Hong Kong

CLIENT:

HSBC

CHANNEL PARTNER:

Tozen HK Ltd

SPECIFICATION:

Balancing valves and a selection of general valves



PROJECT

Domino's Pizza HQ

Commissioning valve units, strainers and associated products from Crane Fluid Systems have been installed at the commissary built for Domino's Pizza Group, the leading pizza delivery company in the UK and Ireland, at West Ashland, Milton Keynes.

The state of the art facility provides for the planned future growth of Domino's global business. Over 500 of its stores rely on the commissary for the fresh dough and other ingredients they need to produce pizzas.

Crane's isolation and commissioning valves play a vital role in managing energy use within the £20 million building. Boasting a compact, space saving design and fast commissioning, they require fewer on-site joints and thus offer considerable installed cost savings.

Designed by Q2 Architects to the highest environmental standards, the new building's exterior emulates the sleek form of the adjacent MK stadium. It covers an area of 7,400sq m and incorporates production facilities as well as a distribution warehouse.

LOCATION:

Milton Keynes

CLIENT:

Domino's Pizza Group

ARCHITECT:

Q2 Architects

MECHANICAL AND ELECTRICAL CONSULTANT:

Couch Perry & Wilkes LLP

CONTRACTOR:

The Buckingham Group

MECHANICAL AND ELECTRICAL CONTRACTOR:

Walter Miles

DISTRIBUTOR:

BSS (Leicester) Ltd.

SPECIFICATION:

Isolation and commissioning valves

Flange Tables

This information is extracted from the following European, British and American standards:

- BS EN 1092 Circular flanges for pipes, valves, fittings and accessories, PN designated Part 1 Steel flanges.
- Part 2 Cast iron flanges.
- BS 4504 Flanges and bolting for pipes, valves, and fittings metric series (for copper alloy flanges only).
- ANSI B16.1 Cast Iron pipe flanges and flanged fittings.
- ANSI B16.5 Steel pipe flanges and flanged fittings.
- ANSI B16.24 Bronze flanges and flanged fittings BS10 Flanges and bolting for pipes, valves and fittings.

Notes:

1. Raised joint faces are applicable to BS EN 1092-1, BS EN 1092-2, BS10 ANSI table H steel, and classes 150 to 1500 inclusive.
2. ANSI Class 125 refers to cast iron only.
3. ANSI 600, 900, 1500 flange thickness does not include raised face.
4. Dimensions for flanges to BS EN 1092 are given in millimetres only. Dimensions for ANSI and BS 10 flanges are shown in inches with the metric equivalent (to nearest whole millimetre) in brackets.

Nominal Size 15mm (1/2")

BS EN 1092	Dia. of flange	Bolt circle diameter	No. of bolts	Dia. of bolts	Dia. of holes	Dia. of raised face(3) Iron	Dia. of raised face(3) Steel	Height of raised face(3)	Thickness of flange			
									Grey Cast Iron	Copper Alloy	Cast and Forged Steel	Ductile Cast Iron
PN6	80	55	4	M10	11	38	40	2	12 (1)	-	12	-
PN10	95	65	4	M12	14	46	45	2	14 (1)	-	16	14
PN16	95	65	4	M12	14	46	45	2	14 (1)	6 (2)	16	14
PN25	95	65	4	M12	14	46	45	2	16 (1)	8 (2)	16	14
PN40	95	65	4	M12	14	46	45	2	-	9 (2)	16	16
PN64	105	75	4	M12	14	-	45	2	-	-	20	-
ANSI												
Class 125/150	3 ¹ / ₂ (89)	2 ³ / ₈ (60)	4	1 ¹ / ₂ (13)	5 ⁸ / ₁₆ (16)	-	1 ³ / ₈ (35)	1 ¹ / ₁₆ (2)	-	5 ¹ / ₁₆ (8)	7 ¹ / ₁₆ (11)	-
Class 300	3 ³ / ₄ (95)	2 ⁵ / ₈ (67)	4	1 ¹ / ₂ (13)	5 ⁸ / ₁₆ (16)	-	1 ³ / ₈ (35)	1 ¹ / ₁₆ (2)	-	1 ¹ / ₂ (13)	1 ¹ / ₂ (13)	-
Class 600	3 ³ / ₄ (95)	2 ⁵ / ₈ (67)	4	1 ¹ / ₂ (13)	5 ⁸ / ₁₆ (16)	-	1 ³ / ₈ (35)	1 ¹ / ₄ (6)	-	-	9 ¹ / ₁₆ (14)	-
Class 900	4 ³ / ₄ (121)	3 ¹ / ₄ (83)	4	3 ⁴ / ₄ (19)	7 ⁸ / ₁₆ (22)	-	1 ³ / ₈ (35)	1 ¹ / ₄ (6)	-	-	7 ⁸ / ₁₆ (22)	-
Class 1500	4 ³ / ₄ (121)	3 ¹ / ₄ (83)	4	3 ⁴ / ₄ (19)	7 ⁸ / ₁₆ (22)	-	1 ³ / ₈ (35)	1 ¹ / ₄ (6)	-	-	7 ⁸ / ₁₆ (22)	-
BS 10												
Table A	3 ³ / ₄ (95)	2 ⁵ / ₈ (67)	4	1 ¹ / ₂ (13)	9 ¹ / ₁₆ (14)	-	-	-	1 ¹ / ₂ (13)	1 ¹ / ₄ (6)	-	-
Table D	3 ³ / ₄ (95)	2 ⁵ / ₈ (67)	4	1 ¹ / ₂ (13)	9 ¹ / ₁₆ (14)	-	-	-	1 ¹ / ₂ (13)	1 ¹ / ₄ (6)	3 ⁸ / ₁₆ (10)	-
Table E	3 ³ / ₄ (95)	2 ⁵ / ₈ (67)	4	1 ¹ / ₂ (13)	9 ¹ / ₁₆ (14)	-	-	-	1 ¹ / ₂ (13)	1 ¹ / ₄ (6)	3 ⁸ / ₁₆ (10)	-
Table F	3 ³ / ₄ (95)	2 ⁵ / ₈ (67)	4	1 ¹ / ₂ (13)	9 ¹ / ₁₆ (14)	-	-	-	1 ¹ / ₂ (13)	5 ¹ / ₁₆ (8)	3 ⁸ / ₁₆ (10)	-
Table H	4 ¹ / ₂ (114)	3 ¹ / ₄ (83)	4	5 ⁸ / ₁₆ (16)	11 ¹ / ₁₆ (17)	-	2 ¹ / ₄ (57)	1 ¹ / ₁₆ (2)	5 ⁸ / ₁₆ (16)	3 ⁸ / ₁₆ (10)	1 ¹ / ₂ (13)	-

(1) These flange thicknesses are also valid for ductile iron flanges type 21-2 (2) Flange thicknesses for copper alloy are from BS 4504

(3) Copper alloy flanges are always flat-faced

Nominal Size 20mm (3/4")

BS EN 1092	Dia. of flange	Bolt circle diameter	No. of bolts	Dia. of bolts	Dia. of holes	Dia. of raised face(3) Iron	Dia. of raised face(3) Steel	Height of raised face(3)	Thickness of flange			
									Grey Cast Iron	Copper Alloy	Cast and Forged Steel	Ductile Cast Iron
PN6	90	65	4	M10	11	48	50	2	14 (1)	-	14	-
PN10	105	75	4	M12	14	56	58	2	16 (1)	-	18	16
PN16	105	75	4	M12	14	56	58	2	16 (1)	6 (2)	18	16
PN25	105	75	4	M12	14	56	58	2	18 (1)	8 (2)	18	16
PN40	105	75	4	M12	14	56	58	2	-	9 (2)	18	18
PN64	130	90	4	M16	18	-	58	2	-	-	22	-
PN100	130	90	4	M16	18	-	58	2	-	-	22	-
ANSI												
Class 125/150	37/8 (98)	23/4 (70)	4	1/2 (13)	5/8 (16)	-	111/16 (43)	1/16 (2)	-	11/32 (9)	9/16 (14)	-
Class 300	45/8 (117)	31/4 (83)	4	5/8 (16)	3/4 (19)	-	111/16 (43)	1/16 (2)	-	17/32 (13)	5/8 (16)	-
Class 600	45/8 (117)	31/4 (83)	4	5/8 (16)	3/4 (19)	-	111/16 (43)	1/4 (6)	-	-	5/8 (16)	-
Class 900	51/8 (130)	31/2 (89)	4	3/4 (19)	7/8 (22)	-	111/16 (43)	1/4 (6)	-	-	1 (25)	-
Class 1500	51/8 (130)	31/2 (89)	4	3/4 (19)	7/8 (22)	-	111/16 (43)	1/4 (6)	-	-	1 (25)	-
BS 10												
Table A	4 (102)	27/8 (73)	4	1/2 (13)	9/16 (14)	-	-	-	1/2 (13)	1/4 (6)	-	-
Table D	4 (102)	27/8 (73)	4	1/2 (13)	9/16 (14)	-	-	-	1/2 (13)	1/4 (6)	3/8 (10)	-
Table E	4 (102)	27/8 (73)	4	1/2 (13)	9/16 (14)	-	-	-	1/2 (13)	1/4 (6)	3/8 (10)	-
Table F	4 (102)	27/8 (73)	4	1/2 (13)	9/16 (14)	-	-	-	1/2 (13)	5/16 (8)	3/8 (10)	-
Table H	41/2 (114)	31/4 (83)	4	5/8 (16)	11/16 (17)	-	21/4 (57)	1/16 (2)	5/8 (16)	3/8 (10)	1/2 (13)	-

(1) These flange thicknesses are also valid for ductile iron flanges type 21-2 (2) Flange thicknesses for copper alloy are from BS 4504 (3) Copper alloy flanges are always flat-faced

Nominal Size 25mm (1")

BS EN 1092	Dia. of flange	Bolt circle diameter	No. of bolts	Dia. of bolts	Dia. of holes	Dia. of raised face(3) Iron	Dia. of raised face(3) Steel	Height of raised face(3) Iron	Height of raised face(3) Steel	Thickness of flange			
										Grey Cast Iron	Copper Alloy	Cast and Forged Steel	Ductile Cast Iron
PN 6	100	75	4	M10	11	58	60	3	2	14 (1)	-	14	-
PN10	115	85	4	M12	14	65	68	3	2	16 (1)	-	18	16
PN16	115	85	4	M12	14	65	68	3	2	16 (1)	8 (2)	18	16
PN25	115	85	4	M12	14	65	68	3	2	18 (1)	9 (2)	18	16
PN40	115	85	4	M12	14	65	68	3	2	-	11 (2)	18	18
PN64	140	100	4	M16	18	-	68	-	2	-	-	24	-
PN100	140	100	4	M16	18	-	68	-	2	-	-	24	-
ANSI													
Class 125/150	41/4 (114)	31/8 (79)	4	1/2 (13)	5/8 (16)	-	2 (51)	-	1/16 (2)	7/16 (11)	3/8 (10)	7/16 (11)	9/10 (14)
Class 300	47/8 (124)	31/2 (89)	4	5/8 (16)	3/4 (19)	-	2 (51)	-	1/16 (2)	-	19/32 (15)	11/16 (17)	-
Class 600	47/8 (124)	31/2 (89)	4	5/8 (16)	3/4 (19)	-	2 (51)	-	1/4 (6)	-	-	11/16 (17)	-
Class 900	57/8 (149)	4 (102)	4	7/8 (22)	1 (25)	-	2 (51)	-	1/4 (6)	-	-	11/8 (29)	-
Class 1500	57/8 (149)	4 (102)	4	7/8 (22)	1 (25)	-	2 (51)	-	1/4 (6)	-	-	11/8 (29)	-
BS 10													
Table A	41/2 (114)	31/4 (83)	4	1/2 (13)	9/16 (14)	-	-	-	-	1/2 (13)	5/16 (8)	-	-
Table D	41/2 (114)	31/4 (83)	4	1/2 (13)	9/16 (14)	-	-	-	-	1/2 (13)	5/16 (8)	3/8 (10)	-
Table E	41/2 (114)	31/4 (83)	4	1/2 (13)	9/16 (14)	-	-	-	-	1/2 (13)	5/16 (8)	3/8 (10)	-
Table F	43/4 (121)	37/16 (87)	4	5/8 (16)	11/16 (17)	-	-	-	-	1/2 (13)	3/8 (10)	3/8 (10)	-
Table H	43/4 (121)	37/16 (87)	4	5/8 (16)	11/16 (17)	-	21/2 (64)	-	1/16 (2)	3/4 (19)	7/16 (11)	9/16 (14)	-

Nominal Size 32mm (1 1/4")

BS EN 1092	Dia. of flange	Bolt circle diameter	No. of bolts	Dia. of bolts	Dia. of holes Iron	Dia. of holes Steel	Dia. of raised face(3) Iron	Dia. of raised face(3) Steel	Height of raised face(3) Iron	Height of raised face(3) Steel	Thickness of flange			
											Grey Cast Iron	Copper Alloy	Cast and Forged Steel	Ductile Cast Iron
PN 6	120	90	4	M12	14	14	69	70	3	2	16 (1)	-	14	-
PN10	140	100	4	M16	19	18	76	78	3	2	18 (1)	-	18	18
PN16	140	100	4	M16	19	18	76	78	3	2	18 (1)	8 (2)	18	18
PN25	140	100	4	M16	19	18	76	78	3	2	20 (1)	9 (2)	18	18
PN40	140	100	4	M16	19	18	76	78	3	2	-	11 (2)	18	20
PN64	155	110	4	M20	-	22	-	78	-	2	-	-	26	-
PN100	155	110	4	M20	-	22	-	78	-	2	-	-	26	-
ANSI														
Class 125/150	4 5/8 (117)	3 1/2 (89)	4	1/2 (13)	5/8 (16)	5/8 (16)	-	2 1/2 (64)	-	1/16 (2)	1/2 (13)	1 3/32 (10)	1/2 (13)	5/8 (16)
Class 300	5 1/4 (133)	3 7/8 (98)	4	5/8 (16)	-	3/4 (19)	-	2 1/2 (64)	-	1/16 (2)	-	5/8 (16)	3/4 (19)	-
Class 600	5 1/4 (133)	3 7/8 (98)	4	5/8 (16)	-	3/4 (19)	-	2 1/2 (64)	-	1/4 (6)	-	-	1 3/16 (21)	-
Class 900	6 1/4 (159)	4 3/8 (111)	4	7/8 (22)	-	1 (25)	-	2 1/2 (64)	-	1/4 (6)	-	-	1 1/8 (29)	-
Class 1500	6 1/4 (159)	4 3/8 (111)	4	7/8 (22)	-	1 (25)	-	2 1/2 (64)	-	1/4 (6)	-	-	1 1/8 (29)	-
BS 10														
Table A	4 3/4 (121)	3 7/16 (87)	4	1/2 (13)	9/16 (14)	9/16 (14)	-	-	-	-	5/8 (16)	5/16 (8)	-	-
Table D	4 3/4 (121)	3 7/16 (87)	4	1/2 (13)	9/16 (14)	9/16 (14)	-	-	-	-	5/8 (16)	5/16 (8)	1/2 (13)	-
Table E	4 3/4 (121)	3 7/16 (87)	4	1/2 (13)	9/16 (14)	9/16 (14)	-	-	-	-	5/8 (16)	5/16 (8)	1/2 (13)	-
Table F	5 1/4 (133)	3 7/8 (98)	4	5/8 (16)	1 1/16 (17)	1 1/16 (17)	-	-	-	-	5/8 (16)	3/8 (10)	1/2 (13)	-
Table H	5 1/4 (133)	3 7/8 (98)	4	5/8 (16)	1 1/16 (17)	1 1/16 (17)	-	3 (76)	-	1/16 (2)	7/8 (22)	7/16 (11)	1 1/16 (17)	-

(1) These flange thicknesses are also valid for ductile iron flanges type 21-2 (2) Flange thicknesses for copper alloy are from BS 4504
 (3) Copper alloy flanges are always flat-faced

Nominal Size 40mm (1 1/2")

BS EN 1092	Dia. of flange	Bolt circle diameter	No. of bolts	Dia. of bolts	Dia. of holes Iron	Dia. of holes Steel	Dia. of raised face(3) Iron	Dia. of raised face(3) Steel	Height of raised face(3) Iron	Height of raised face(3) Steel	Thickness of flange			
											Grey Cast Iron	Copper Alloy	Cast and Forged Steel	Ductile Cast Iron
PN6	130	100	4	M12	14	14	78	80	3	2	16 (1)	-	14	-
PN10	150	110	4	M16	19	18	84	88	3	2	18 (1)	-	18	19
PN16	150	110	4	M16	19	18	84	88	3	2	18 (1)	9 (2)	18	19
PN25	150	110	4	M16	19	18	84	88	3	2	20 (1)	11 (2)	18	19
PN40	150	110	4	M16	19	18	84	88	3	2	-	13 (2)	18	19
PN64	170	125	4	M20	-	22	-	88	-	2	-	-	28	-
PN100	170	125	4	M20	-	22	-	88	-	2	-	-	28	-
ANSI														
Class 125/150	5 (127)	3 7/8 (98)	4	1/2 (13)	5/8 (16)	5/8 (16)	-	2 7/8 (73)	-	1/16 (2)	9/16 (14)	7/16 (11)	9/16 (14)	1 1/16 (17)
Class 300	6 1/8 (156)	4 1/2 (114)	4	3/4 (19)	-	7/8 (22)	-	2 7/8 (73)	-	1/16 (2)	-	1 1/16 (17)	1 3/16 (21)	-
Class 600	6 1/8 (156)	4 1/2 (114)	4	3/4 (19)	-	7/8 (22)	-	2 7/8 (73)	-	1/4 (6)	-	-	7/8 (22)	-
Class 900	7 (178)	4 7/8 (124)	4	1 (25)	-	1 1/8 (29)	-	2 7/8 (73)	-	1/4 (6)	-	-	1 1/4 (32)	-
Class 1500	7 (178)	4 7/8 (124)	4	1 (25)	-	1 1/8 (29)	-	2 7/8 (73)	-	1/4 (6)	-	-	1 1/4 (32)	-
BS 10														
Table A	5 1/4 (133)	3 7/8 (98)	4	1/2 (13)	9/16 (14)	9/16 (14)	-	-	-	-	5/8 (16)	3/8 (10)	-	-
Table D	5 1/4 (133)	3 7/8 (98)	4	1/2 (13)	9/16 (14)	9/16 (14)	-	-	-	-	5/8 (16)	3/8 (10)	1/2 (13)	-
Table E	5 1/4 (133)	3 7/8 (98)	4	1/2 (13)	9/16 (14)	9/16 (14)	-	-	-	-	5/8 (16)	3/8 (10)	1/2 (13)	-
Table F	5 1/2 (140)	4 1/8 (105)	4	5/8 (16)	1 1/16 (17)	1 1/16 (17)	-	-	-	-	5/8 (16)	7/16 (11)	1/2 (13)	-
Table H	5 1/2 (140)	4 1/8 (105)	4	5/8 (16)	1 1/16 (17)	1 1/16 (17)	-	3 1/4 (83)	-	1/16 (2)	7/8 (22)	1/2 (13)	1 1/16 (17)	-

(1) These flange thicknesses are also valid for ductile iron flanges type 21-2
 (2) Flange thicknesses for copper alloy are from BS 4504
 (3) Copper alloy flanges are always flat-faced

Nominal Size 50mm (2")

BS EN 1092	Dia. of flange	Bolt circle diameter	No. of bolts	Dia. of bolts	Dia. of holes Iron	Dia. of holes Steel	Dia. of raised face(3) Iron	Dia. of raised face(3) Steel	Height of raised face(3) Iron	Height of raised face(3) Steel	Thickness of flange			
											Grey Cast Iron	Copper Alloy	Cast and Forged Steel	Ductile Cast Iron
PN 6	140	110	4	M12	14	14	88	90	3	2	16 (1)	-	14	-
PN10	165	125	4	M16	19	18	99	102	3	2	20 (1)	-	18	19
PN16	165	125	4	M16	19	18	99	102	3	2	20 (1)	11 (2)	18	19
PN25	165	125	4	M16	19	18	99	102	3	2	22 (1)	11 (2)	20	19
PN40	165	125	4	M16	19	18	99	102	3	2	-	13 (2)	20	19
PN64	180	135	4	M20	-	22	-	102	-	2	-	-	26	-
PN100	195	145	4	M24	-	26	-	102	-	2	-	-	30	-
ANSI														
Class 125/150	6 (152)	4 ³ / ₄ (121)	4	5/8 (16)	3/4 (19)	3/4 (19)	-	3 ⁵ / ₈ (92)	-	1/16 (2)	5/8 (16)	1/2 (13)	5/8 (16)	-
Class 300	6 ¹ / ₂ (165)	5 (127)	8	5/8 (16)	-	3/4 (19)	-	3 ⁵ / ₈ (92)	-	1/16 (2)	-	3/4 (19)	7/8 (22)	-
Class 600	6 ¹ / ₂ (165)	5 (127)	8	5/8 (16)	-	3/4 (19)	-	3 ⁵ / ₈ (92)	-	1/4 (6)	-	- 1	(25)	-
Class 900	8 ¹ / ₂ (216)	6 ¹ / ₂ (165)	8	7/8 (22)	-	1 (25)	-	3 ⁵ / ₈ (92)	-	1/4 (6)	-	- 1	1/2 (38)	-
Class 1500	8 ¹ / ₂ (216)	6 ¹ / ₂ (165)	8	7/8 (22)	-	1 (25)	-	3 ⁵ / ₈ (92)	-	1/4 (6)	-	- 1	1/2 (38)	-
BS 10														
Table A	6 (152)	4 ¹ / ₂ (114)	4	5/8 (16)	1 ¹ / ₁₆ (17)	1 ¹ / ₁₆ (17)	-	-	-	-	5/8 (16)	3/8 (10)	-	-
Table D	6 (152)	4 ¹ / ₂ (114)	4	5/8 (16)	1 ¹ / ₁₆ (17)	1 ¹ / ₁₆ (17)	-	-	-	-	1 ¹ / ₁₆ (17)	3/8 (10)	9/16 (14)	-
Table E	6 (152)	4 ¹ / ₂ (114)	4	5/8 (16)	1 ¹ / ₁₆ (17)	1 ¹ / ₁₆ (17)	-	-	-	-	3/4 (19)	3/8 (10)	9/16 (14)	-
Table F	6 ¹ / ₂ (165)	5 (127)	4	5/8 (16)	1 ¹ / ₁₆ (17)	1 ¹ / ₁₆ (17)	-	-	-	-	3/4 (19)	7/16 (11)	5/8 (16)	-
Table H	6 ¹ / ₂ (165)	5 (127)	4	5/8 (16)	1 ¹ / ₁₆ (17)	1 ¹ / ₁₆ (17)	-	4 (102)	-	1/16 (2)	1 (25)	1/2 (13)	3/4 (19)	-

(1) These flange thicknesses are also valid for ductile iron flanges type 21-2 (2) Flange thicknesses for copper alloy are from BS 4504 (3) Copper alloy flanges are always flat-faced

Nominal Size 65mm (2 1/2")

BS EN 1092	Dia. of flange	Bolt circle diameter	No. of bolts	Dia. of bolts	Dia. of holes Iron	Dia. of holes Steel	Dia. of raised face(3) Iron	Dia. of raised face(3) Steel	Height of raised face(3) Iron	Height of raised face(3) Steel	Thickness of flange			
											Grey Cast Iron	Copper Alloy	Cast and Forged Steel	Ductile Cast Iron
PN 6	160	130	4	M12	14	14	108	110	2	3	16 (1)	-	14	-
PN 10	185	145	4 (2)	M16	19	18	118	122	2	3	20 (1)	-	18	19
PN 16	185	145	4 (2)	M16	19	18	118	122	2	3	20 (1)	13	18	19
PN 25	185	145	8	M16	19	18	118	122	2	3	24 (1)	13	22	19
PN 40	185	145	8	M16	19	18	118	122	2	3	-	14	22	19
PN 64	205	160	8	M20	-	22	-	122	2	-	-	-	26	-
PN 100	220	170	8	M24	-	26	-	122	2	-	-	-	34	-
ANSI														
Class 125/150	7 (178)	5 ¹ / ₂ (140)	4	5/8 (16)	3/4 (19)	3/4 (19)	-	4 ¹ / ₈ (105)	-	1/16 (2)	1 ¹ / ₁₆ (17)	9/16 (14)	1 ¹ / ₁₆ (17)	-
Class 300	7 ¹ / ₂ (191)	5 ⁷ / ₈ (149)	8	3/4 (19)	-	7/8 (22)	-	4 ¹ / ₈ (105)	-	1/16 (2)	-	1 ³ / ₁₆ (21)	1 (25)	-
Class 600	7 ¹ / ₂ (191)	5 ⁷ / ₈ (149)	8	3/4 (19)	-	7/8 (22)	-	4 ¹ / ₈ (105)	-	1/4 (6)	-	-	1 ¹ / ₈ (29)	-
Class 900	9 ⁵ / ₈ (244)	7 ¹ / ₂ (191)	8	1 (25)	-	1 ¹ / ₈ (29)	-	4 ¹ / ₈ (105)	-	1/4 (6)	-	-	1 ⁵ / ₈ (41)	-
Class 1500	9 ⁵ / ₈ (244)	7 ¹ / ₂ (191)	8	1 (25)	-	1 ¹ / ₈ (29)	-	4 ¹ / ₈ (105)	-	1/4 (6)	-	-	1 ⁵ / ₈ (41)	-
BS 10														
Table A	6 ¹ / ₂ (165)	5 (127)	4	5/8 (16)	1 ¹ / ₁₆ (17)	1 ¹ / ₁₆ (17)	-	-	-	-	1 ¹ / ₁₆ (17)	7/16 (11)	-	-
Table D	6 ¹ / ₂ (165)	5 (127)	4	5/8 (16)	1 ¹ / ₁₆ (17)	1 ¹ / ₁₆ (17)	-	-	-	-	1 ¹ / ₁₆ (17)	7/16 (11)	9/16 (14)	-
Table E	6 ¹ / ₂ (165)	5 (127)	4	5/8 (16)	1 ¹ / ₁₆ (17)	1 ¹ / ₁₆ (17)	-	-	-	-	3/4 (19)	7/16 (11)	9/16 (14)	-
Table F	7 ¹ / ₄ (184)	5 ³ / ₄ (146)	8	5/8 (16)	1 ¹ / ₁₆ (17)	1 ¹ / ₁₆ (17)	-	-	-	-	3/4 (19)	1/2 (13)	5/8 (16)	-
Table H	7 ¹ / ₄ (184)	5 ³ / ₄ (146)	8	5/8 (16)	1 ¹ / ₁₆ (17)	1 ¹ / ₁₆ (17)	-	4 ¹ / ₂ (114)	-	1/16 (2)	1 (25)	9/16 (14)	3/4 (19)	-

(1) These flange thicknesses are also valid for ductile iron flanges type 21-2 (2) Steel flanges in this DN and PN may be supplied with 8 holes. For compliance with these, equivalent cast iron flanges may be supplied with 8 holes as special order and after agreement between manufacturer and customer (3) Flange thicknesses for copper alloy are from BS 4504 (4) Copper alloy flanges are always flat-faced

Nominal Size 80mm (3")

BS EN 1092	Dia. of flange	Bolt circle diameter	No. of bolts	Dia. of bolts	Dia. of holes Iron	Dia. of holes Steel	Dia. of raised face(3) Iron	Dia. of raised face(3) Steel	Height of raised face(3) Iron	Height of raised face(3) Steel	Thickness of flange			
											Grey Cast Iron	Copper Alloy	Cast and Forged Steel	Ductile Cast Iron
PN 6	190	150	4	M16	19	18	124	128	3	2	18 (1)	-	16	-
PN10	200	160	8	M16	19	18	132	138	3	2	22 (1)	-	20	19
PN16	200	160	8	M16	19	18	132	138	3	2	22 (1)	13 (2)	20	19
PN25	200	160	8	M16	19	18	132	138	3	2	26 (1)	14 (2)	24	19
PN40	200	160	8	M16	19	18	132	138	3	2	-	16 (2)	24	19
PN64	215	170	8	M20	-	22	-	138	-	2	-	-	28	-
PN100	230	180	8	M24	-	26	-	138	-	2	-	-	36	-
ANSI														
Class 125/150	7 ¹ / ₂ (191)	6 (152)	4	5/8 (16)	3/4 (19)	3/4 (19)	-	5 (127)	-	1/16 (2)	3/4 (19)	5/8 (16)	3/4 (19)	-
Class 300	8 ¹ / ₄ (210)	6 ⁵ / ₈ (168)	8	3/4 (19)	-	7/8 (22)	-	5 (127)	-	1/16 (2)	-	2 ⁹ / ₃₂ (23)	1 ¹ / ₈ (29)	-
Class 600	8 ¹ / ₄ (210)	6 ⁵ / ₈ (168)	8	3/4 (19)	-	7/8 (22)	-	5 (127)	-	1/4 (6)	-	-	1 ¹ / ₄ (32)	-
Class 900	9 ¹ / ₂ (241)	7 ¹ / ₂ (192)	8	7/8 (22)	-	1 (25)	-	5 (127)	-	1/4 (6)	-	-	1 ¹ / ₂ (38)	-
Class 1500	10 ¹ / ₂ (267)	8 (203)	8	1 ¹ / ₈ (29)	-	1 ¹ / ₄ (32)	-	5 (127)	-	1/4 (6)	-	-	1 ⁷ / ₈ (48)	-
BS 10														
Table A	7 ¹ / ₄ (184)	5 ³ / ₄ (146)	4	5/8 (16)	1 ¹ / ₁₆ (17)	1 ¹ / ₁₆ (17)	-	-	-	-	1 ¹ / ₁₆ (17)	1/2 (13)	-	-
Table D	7 ¹ / ₄ (184)	5 ³ / ₄ (146)	4	5/8 (16)	1 ¹ / ₁₆ (17)	1 ¹ / ₁₆ (17)	-	-	-	-	3/4 (19)	1/2 (13)	9/16 (14)	-
Table E	7 ¹ / ₄ (184)	5 ³ / ₄ (146)	4	5/8 (16)	1 ¹ / ₁₆ (17)	1 ¹ / ₁₆ (17)	-	-	-	-	3/4 (19)	1/2 (13)	9/16 (14)	-
Table F	8 (203)	6 ¹ / ₂ (165)	8	5/8 (16)	1 ¹ / ₁₆ (17)	1 ¹ / ₁₆ (17)	-	-	-	-	3/4 (19)	9/16 (14)	5/8 (16)	-
Table H	8 (203)	6 ¹ / ₂ (165)	8	5/8 (16)	1 ¹ / ₁₆ (17)	1 ¹ / ₁₆ (17)	-	5 (127)	-	1/16 (2)	1 ¹ / ₈ (29)	5/8 (16)	7/8 (22)	-

(1) These flange thicknesses are also valid for ductile iron flanges type 21-2 (2) Flange thicknesses for copper alloy are from BS 4504 (3) Copper alloy flanges are always flat-faced

Nominal Size 100mm (4")

BS EN 1092	Dia. of flange	Bolt circle diameter	No. of bolts	Dia. of bolts	Dia. of holes Iron	Dia. of holes Steel	Dia. of raised face(3) Iron	Dia. of raised face(3) Steel	Height of raised face(3) Iron	Height of raised face(3) Steel	Thickness of flange			
											Grey Cast Iron	Copper Alloy	Cast and Forged Steel	Ductile Cast Iron
PN 6	210	170	4	M16	19	18	144	148	3	2	18 (1)	-	16	-
PN10	220	180	8	M16	19	18	156	158	3	2	24 (1)	-	20	19
PN16	220	180	8	M16	19	18	156	158	3	2	24 (1)	16 (2)	20	19
PN25	235	190	8	M20	23	22	156	162	3	2	28 (1)	17 (2)	24	19
PN40	235	190	8	M20	23	22	156	162	3	2	-	19 (2)	24	19
PN64	250	200	8	M24	-	26	-	162	-	2	-	-	30	-
PN100	265	210	8	M27	-	30	-	162	-	2	-	-	40	-
ANSI														
Class 125/150	9 (229)	7 ¹ / ₂ (191)	8	5/8 (16)	3/4 (19)	3/4 (19)	-	6 ³ / ₁₆ (157)	-	1/16 (2)	1 ⁵ / ₁₆ (24)	1 ¹ / ₁₆ (17)	1 ⁵ / ₁₆ (24)	-
Class 300	10 (254)	7 ⁷ / ₈ (200)	8	3/4 (19)	-	7/8 (22)	-	6 ³ / ₁₆ (157)	-	1/16 (2)	-	1 ¹ / ₁₆ (27)	1 ¹ / ₄ (32)	-
Class 600	10 ³ / ₄ (273)	8 ¹ / ₂ (216)	8	7/8 (22)	-	1 (25)	-	6 ³ / ₁₆ (157)	-	1/4 (6)	-	-	1 ¹ / ₂ (38)	-
Class 900	11 ¹ / ₂ (292)	9 ¹ / ₄ (235)	8	1 ¹ / ₈ (29)	-	1 ¹ / ₄ (32)	-	6 ³ / ₁₆ (157)	-	1/4 (6)	-	-	1 ³ / ₄ (44)	-
Class 1500	12 ¹ / ₄ (311)	9 ¹ / ₂ (241)	8	1 ¹ / ₄ (32)	-	1 ³ / ₈ (35)	-	6 ³ / ₁₆ (157)	-	1/4 (6)	-	-	2 ¹ / ₈ (54)	-
BS 10														
Table A	8 ¹ / ₂ (216)	7 (178)	4	5/8 (16)	1 ¹ / ₁₆ (17)	1 ¹ / ₁₆ (17)	-	-	-	-	3/4 (19)	5/8 (16)	-	-
Table D	8 ¹ / ₂ (216)	7 (178)	4	5/8 (16)	1 ¹ / ₁₆ (17)	1 ¹ / ₁₆ (17)	-	-	-	-	3/4 (19)	5/8 (16)	1 ¹ / ₁₆ (17)	-
Table E	8 ¹ / ₂ (216)	7 (178)	8	5/8 (16)	1 ¹ / ₁₆ (17)	1 ¹ / ₁₆ (17)	-	-	-	-	7/8 (22)	5/8 (16)	1 ¹ / ₁₆ (17)	-
Table F	9 (229)	7 ¹ / ₂ (191)	8	5/8 (16)	1 ¹ / ₁₆ (17)	1 ¹ / ₁₆ (17)	-	-	-	-	7/8 (22)	1 ¹ / ₁₆ (17)	3/4 (19)	-
Table H	9 (229)	7 ¹ / ₂ (191)	8	5/8 (16)	1 ¹ / ₁₆ (17)	1 ¹ / ₁₆ (17)	-	6 (152)	-	1/16 (2)	1 ¹ / ₄ (32)	3/4 (19)	1 (25)	-

(1) These flange thicknesses are also valid for ductile iron flanges type 21-2 (2) Flange thicknesses for copper alloy are from BS 4504 (3) Copper alloy flanges are always flat-faced

Nominal Size 125mm (5")

BS EN 1092	Dia. of flange	Bolt circle diameter	No. of bolts	Dia. of bolts	Dia. of holes Iron	Dia. of holes Steel	Dia. of raised face(3) Iron	Dia. of raised face(3) Steel	Height of raised face(3) Iron	Height of raised face(3) Steel	Thickness of flange			
											Grey Cast Iron	Copper Alloy	Cast and Forged Steel	Ductile Cast Iron
PN 6	240	200	8	M16	19	18	174	178	3	2	20 (1)	-	18	-
PN10	250	210	8	M16	19	18	184	188	3	2	26 (1)	-	22	19
PN16	250	210	8	M16	19	18	184	188	3	2	26 (1)	-	22	19
PN25	270	220	8	M24	28	26	184	188	3	2	30 (1)	-	26	19
PN40	270	220	8	M24	28	26	184	188	3	2	-	-	26	23.5
PN64	295	240	8	M27	-	30	-	188	-	2	-	-	34	-
PN100	315	250	8	M30	-	33	-	188	-	2	-	-	40	-
ANSI														
Class 125/150	10 (254)	8 ¹ / ₂ (216)	8	3/4 (19)	7/8 (22)	7/8 (22)	-	7 ⁵ / ₁₆ (186)	-	1/16 (2)	5 ¹ / ₁₆ (24)	3/4 (19)	5/16 (24)	-
Class 300	11 (279)	9 ¹ / ₄ (235)	8	3/4 (19)	-	7/8 (22)	-	7 ⁵ / ₁₆ (186)	-	1/16 (2)	-	1 ¹ / ₈ (29)	1 ³ / ₈ (35)	-
Class 600	13 (330)	10 ¹ / ₂ (267)	8	1 (25)	-	1 ¹ / ₈ (29)	-	7 ⁵ / ₁₆ (186)	-	1/4 (6)	-	-	1 ³ / ₄ (44)	-
Class 900	13 ³ / ₄ (349)	11 (279)	8	1 ¹ / ₄ (32)	-	1 ³ / ₈ (35)	-	7 ⁵ / ₁₆ (186)	-	1/4 (6)	-	-	2 (51)	-
Class 1500	14 ³ / ₄ (375)	11 ¹ / ₂ (292)	8	1 ¹ / ₂ (38)	-	1 ⁵ / ₈ (41)	-	7 ⁵ / ₁₆ (186)	-	1/4 (6)	-	-	2 ⁷ / ₈ (73)	-
BS 10														
Table A	10 (254)	8 ¹ / ₄ (210)	4	5/8 (16)	1 ¹ / ₁₆ (17)	1 ¹ / ₁₆ (17)	-	-	-	-	3/4 (19)	1 ¹ / ₁₆ (17)	-	-
Table D	10 (254)	8 ¹ / ₄ (210)	8	5/8 (16)	1 ¹ / ₁₆ (17)	1 ¹ / ₁₆ (17)	-	-	-	-	1 ³ / ₁₆ (21)	1 ¹ / ₁₆ (17)	1 ¹ / ₁₆ (17)	-
Table E	10 (254)	8 ¹ / ₄ (210)	8	5/8 (16)	1 ¹ / ₁₆ (17)	1 ¹ / ₁₆ (17)	-	-	-	-	7/8 (22)	1 ¹ / ₁₆ (17)	1 ¹ / ₁₆ (17)	-
Table F	11 (279)	9 ¹ / ₄ (235)	8	3/4 (19)	7/8 (22)	7/8 (22)	-	-	-	-	1 (25)	3/4 (19)	7/8 (22)	-
Table H	11 (279)	9 ¹ / ₄ (235)	8	3/4 (19)	7/8 (22)	7/8 (22)	-	7 (178)	-	1/16 (2)	1 ³ / ₈ (35)	7/8 (22)	1 ¹ / ₈ (29)	-

(1) These flange thicknesses are also valid for ductile iron flanges type 21-2

(2) Copper alloy flanges are always flat-faced

Nominal Size 150mm (6")

BS EN 1092	Dia. of flange	Bolt circle diameter	No. of bolts	Dia. of bolts	Dia. of holes Iron	Dia. of holes Steel	Dia. of raised face(3) Iron	Dia. of raised face(3) Steel	Height of raised face(3) Iron	Height of raised face(3) Steel	Thickness of flange			
											Grey Cast Iron	Copper Alloy	Cast and Forged Steel	Ductile Cast Iron
PN6	265	225	8	M16	19	18	199	202	3	2	20 (1)	-	18	-
PN10	285	240	8	M20	23	22	211	212	3	2	26 (1)	-	22	19
PN16	285	240	8	M20	23	22	211	212	3	2	26 (1)	-	22	19
PN25	300	250	8	M24	28	26	211	218	3	2	34 (1)	-	28	20
PN40	300	250	8	M24	28	26	211	218	3	2	-	-	28	26
PN64	345	280	8	M30	-	33	-	218	-	2	-	-	36	-
PN100	355	290	12	M30	-	33	-	218	-	2	-	-	44	-
ANSI														
Class 125/150	11 (279)	9 ¹ / ₂ (241)	8	3/4 (19)	7/8 (22)	7/8 (22)	-	8 ¹ / ₂ (216)	-	1/16 (2)	1 (25)	1 ³ / ₁₆ (21)	1 (25)	-
Class 300	12 ¹ / ₂ (318)	10 ⁵ / ₈ (270)	12	3/4 (19)	-	7/8 (22)	-	8 ¹ / ₂ (216)	-	1/16 (2)	-	1 ³ / ₁₆ (30)	1 ⁷ / ₁₆ (37)	-
Class 600	14 (356)	11 ¹ / ₂ (292)	12	1 (25)	-	1 ¹ / ₈ (29)	-	8 ¹ / ₂ (216)	-	1/4 (6)	-	-	1 ⁷ / ₈ (48)	-
Class 900	15 (381)	12 ¹ / ₂ (318)	12	1 ¹ / ₈ (29)	-	1 ¹ / ₄ (32)	-	8 ¹ / ₂ (216)	-	1/4 (6)	-	-	2 ³ / ₁₆ (56)	-
Class 1500	15 ¹ / ₂ (394)	12 ¹ / ₂ (318)	12	1 ³ / ₈ (35)	-	1 ¹ / ₂ (38)	-	8 ¹ / ₂ (216)	-	1/4 (6)	-	-	3 ¹ / ₄ (83)	-
BS 10														
Table A	11 (279)	9 ¹ / ₄ (235)	4	5/8 (16)	1 ¹ / ₁₆ (17)	1 ¹ / ₁₆ (17)	-	-	-	-	1 ³ / ₁₆ (21)	1 ¹ / ₁₆ (17)	-	-
Table D	11 (279)	9 ¹ / ₄ (235)	8	5/8 (16)	1 ¹ / ₁₆ (17)	1 ¹ / ₁₆ (17)	-	-	-	-	1 ³ / ₁₆ (21)	1 ¹ / ₁₆ (17)	1 ¹ / ₁₆ (17)	-
Table E	11 (279)	9 ¹ / ₄ (235)	8	3/4 (19)	7/8 (22)	7/8 (22)	-	-	-	-	7/8 (22)	1 ¹ / ₁₆ (17)	1 ¹ / ₁₆ (17)	-
Table F	12 (305)	10 ¹ / ₄ (260)	12	3/4 (19)	7/8 (22)	7/8 (22)	-	-	-	-	1 (25)	7/8 (22)	7/8 (22)	-
Table H	12 (305)	10 ¹ / ₄ (260)	12	3/4 (19)	7/8 (22)	7/8 (22)	-	8 ¹ / ₄ (210)	-	1/16 (2)	1 ³ / ₈ (35)	1 (25)	1 ¹ / ₈ (29)	-

(1) These flange thicknesses are also valid for ductile iron flanges type 21-2

(2) Copper alloy flanges are always flat-faced

Nominal Size 200mm (8")

BS EN 1092	Dia. of flange	Bolt circle diameter	No. of bolts	Dia. of bolts	Dia. of holes Iron	Dia. of holes Steel	Dia. of raised face(3) Iron	Dia. of raised face(3) Steel	Height of raised face(3) Iron	Height of raised face(3) Steel	Thickness of flange			
											Grey Cast Iron	Copper Alloy	Cast and Forged Steel	Ductile Cast Iron
PN 6	320	280	8	M16	19	18	254	258	3	2	22 (1)	-	20	-
PN10	340	295	8	M20	23	22	266	268	3	2	26 (1)	-	24	20
PN16	340	295	12	M20	23	22	266	268	3	2	30 (1)	-	24	20
PN25	360	310	12	M24	28	26	274	278	3	2	34 (1)	-	30	22
PN40	375	320	12	M27	31	30	284	285	3	2	-	-	34	30
PN64	415	345	12	M33	-	36	-	285	-	2	-	-	42	-
PN100	430	360	12	M33	-	36	-	285	-	2	-	-	52	-
ANSI														
Class 125/150	13 ¹ / ₂ (343)	11 ³ / ₄ (298)	8	3/4 (19)	7/8 (22)	7/8 (22)	-	10 ⁵ / ₈ (270)	-	1/16 (2)	1 ¹ / ₈ (29)	1 ⁵ / ₁₆ (24)	1 ¹ / ₈ (29)	-
Class 300	15 (381)	13 (330)	12	7/8 (22)	-	1 (25)	-	10 ⁵ / ₈ (270)	-	1/16 (2)	-	1 ³ / ₈ (35)	1 ⁵ / ₈ (41)	-
Class 600	16 ¹ / ₂ (419)	13 ³ / ₄ (349)	12	1 ¹ / ₈ (29)	-	1 ¹ / ₄ (32)	-	10 ⁵ / ₈ (270)	-	1/4 (6)	-	-	2 ³ / ₁₆ (56)	-
Class 900	18 ¹ / ₂ (470)	15 ¹ / ₂ (394)	12	1 ³ / ₈ (35)	-	1 ¹ / ₂ (38)	-	10 ⁵ / ₈ (270)	-	1/4 (6)	-	-	2 ¹ / ₂ (64)	-
Class 1500	19 (438)	15 ¹ / ₂ (394)	12	1 ⁵ / ₈ (41)	-	1 ³ / ₄ (44)	-	10 ⁵ / ₈ (270)	-	1/4 (6)	-	-	3 ⁵ / ₈ (92)	-
BS 10														
Table A	13 ¹ / ₄ (337)	11 ¹ / ₂ (292)	8	5/8 (16)	1 ¹ / ₁₆ (17)	1 ¹ / ₁₆ (17)	-	-	-	-	7/8 (22)	3/4 (19)	1/2 (13)	-
Table D	13 ¹ / ₄ (337)	11 ¹ / ₂ (292)	8	5/8 (16)	1 ¹ / ₁₆ (17)	1 ¹ / ₁₆ (17)	-	-	-	-	7/8 (22)	3/4 (19)	3/4 (19)	-
Table E	13 ¹ / ₄ (337)	11 ¹ / ₂ (292)	8	3/4 (19)	7/8 (22)	7/8 (22)	-	-	-	-	1 (25)	3/4 (19)	3/4 (19)	-
Table F	14 ¹ / ₂ (368)	12 ³ / ₄ (324)	12	3/4 (19)	7/8 (22)	7/8 (22)	-	-	-	-	1 ¹ / ₈ (29)	1 (25)	1 (25)	-
Table H	14 ¹ / ₂ (368)	12 ³ / ₄ (324)	12	3/4 (19)	7/8 (22)	7/8 (22)	-	10 ¹ / ₄ (260)	-	1/16 (2)	1 ¹ / ₂ (38)	1 ¹ / ₄ (32)	1 ¹ / ₄ (32)	-

(1) These flange thicknesses are also valid for ductile iron flanges type 21-2

(2) Copper alloy flanges are always flat-faced

Nominal Size 250mm (10")

BS EN 1092	Dia. of flange	Bolt circle diameter	No. of bolts	Dia. of bolts	Dia. of holes Iron	Dia. of holes Steel	Dia. of raised face(3) Iron	Dia. of raised face(3) Steel	Height of raised face(3) Iron	Height of raised face(3) Steel	Thickness of flange			
											Grey Cast Iron	Copper Alloy	Cast and Forged Steel	Ductile Cast Iron
PN6	375	335	12	M16	19	18	309	312	3	2	24 (1)	-	22	-
PN10	395 (2)	350	12	M20	23	22	319	320	3	2	28 (1)	-	26	22
PN16	405 (2)	355	12	M24	28	26	319	320	3	2	32 (1)	-	26	22
PN25	425	370	12	M27	31	30	330	335	3	2	-	-	32	24.5
PN40	450	385	12	M30	34	33	345	345	3	2	-	-	38	34.5
PN64	470	400	12	M33	-	36	-	345	-	2	-	-	46	-
PN100	505	430	12	M36	-	39	-	345	-	2	-	-	60	-
ANSI														
Class 125/150	16 (406)	14 ¹ / ₄ (362)	12	7/8 (22)	1 (25)	1 (25)	-	12 ³ / ₄ (324)	-	1/16 (2)	1 ³ / ₁₆ (30)	1 (25)	1 ³ / ₁₆ (30)	-
Class 300	17 ¹ / ₂ (445)	15 ¹ / ₄ (387)	16	1 (25)	-	1 ¹ / ₈ (29)	-	12 ³ / ₄ (324)	-	1/16 (2)	-	-	1 ⁷ / ₈ (41)	-
Class 600	20 (508)	17 (432)	16	1 ¹ / ₄ (32)	-	1 ³ / ₈ (35)	-	12 ³ / ₄ (324)	-	1/4 (6)	-	-	2 ¹ / ₂ (64)	-
Class 900	21 ¹ / ₂ (546)	18 ¹ / ₂ (470)	16	1 ³ / ₈ (35)	-	1 ¹ / ₂ (38)	-	12 ³ / ₄ (324)	-	1/4 (6)	-	-	2 ³ / ₄ (70)	-
Class 1500	23 (584)	19 (483)	12	1 ⁷ / ₈ (41)	-	2 (51)	-	12 ³ / ₄ (324)	-	1/4 (6)	-	-	4 ¹ / ₄ (108)	-
BS 10														
Table A	16 (406)	14 (356)	8	3/4 (19)	7/8 (22)	7/8 (22)	-	-	-	-	1 ⁵ / ₁₆ (24)	3/4 (19)	-	-
Table D	16 (406)	14 (356)	8	3/4 (19)	7/8 (22)	7/8 (22)	-	-	-	-	1 (25)	3/4 (19)	3/4 (19)	-
Table E	16 (406)	14 (356)	12	3/4 (19)	7/8 (22)	7/8 (22)	-	-	-	-	1 (25)	7/8 (22)	7/8 (22)	-
Table F	17 (432)	15 (381)	12	7/8 (22)	1 (25)	1 (25)	-	-	-	-	1 ¹ / ₈ (29)	1 (25)	1 (25)	-
Table H	17 (432)	15 (381)	12	7/8 (22)	1 (25)	1 (25)	-	12 ¹ / ₄ (311)	-	1/16 (2)	1 ⁵ / ₈ (41)	1 ³ / ₈ (35)	1 ³ / ₈ (35)	-

(1) These flange thicknesses are also valid for ductile iron flanges type 21-2

(2) For ductile iron pipes and fittings the outside diameters shall be: for PN10, D = 400mm, for PN16, D = 400mm

(3) Copper alloy flanges are always flat-faced

Nominal Size 300mm (12")

BS EN 1092	Dia. of flange	Bolt circle diameter	No. of bolts	Dia. of bolts	Dia. of holes Iron	Dia. of holes Steel	Dia. of raised face(3) Iron	Dia. of raised face(3) Steel	Height of raised face(3) Iron	Height of raised face(3) Steel	Thickness of flange			
											Grey Cast Iron	Copper Alloy	Cast and Forged Steel	Ductile Cast Iron
PN6	440	395	12	M20	23	22	363	365	4	2	24 (1)	-	22	-
PN10	445 (2)	400	12	M20	23	22	370	370	4	2	28 (1)	-	26	24.5
PN16	460 (2)	410	12	M24	28	26	370	378	4	2	32 (1)	-	28	24.5
PN25	485	430	16	M27	31	30	389	395	4	2	40 (1)	-	34	27.5
PN40	515	450	16	M30	34	33	409	410	4	2	-	-	42	39.5
PN64	530	460	16	M33	-	36	-	410	-	2	-	-	52	-
PN100	585	500	16	M39	-	42	-	410	-	2	-	-	68	-
ANSI														
Class 125/150	19 (483)	17 (432)	12	7/8 (22)	1 (25)	1 (25)	-	15 (381)	-	1/16 (2)	1 1/4 (32)	1 1/16 (27)	1 1/4 (32)	-
Class 300	20 1/2 (521)	17 3/4 (451)	16	1 1/8 (29)	-	1 1/4 (32)	-	15 (381)	-	1/16 (2)	-	-	2 (51)	-
Class 600	22 (559)	19 1/4 (489)	20	1 1/4 (32)	-	1 3/8 (35)	-	15 (381)	-	1/4 (6)	-	-	2 5/8 (67)	-
Class 900	24 (610)	21 (533)	20	1 3/8 (35)	-	1 1/2 (38)	-	15 (381)	-	1/4 (6)	-	-	3 1/8 (80)	-
Class 1500	26 1/2 (673)	22 1/2 (571)	16	2 (51)	-	2 1/8 (54)	-	15 (381)	-	1/4 (6)	-	-	4 7/8 (124)	-
BS 10														
Table A	18 (457)	16 (406)	8	3/4 (19)	7/8 (22)	7/8 (22)	-	-	-	-	15/16 (24)	7/8 (22)	-	-
Table D	18 (457)	16 (406)	12	3/4 (19)	7/8 (22)	7/8 (22)	-	-	-	-	1 (25)	7/8 (22)	7/8 (22)	-
Table E	18 (457)	16 (406)	12	7/8 (22)	1 (25)	1 (25)	-	-	-	-	1 1/8 (29)	1 (25)	1 (25)	-
Table F	19 1/4 (489)	17 1/4 (438)	16	7/8 (22)	1 (25)	1 (25)	-	-	-	-	1 1/4 (32)	1 1/8 (29)	1 1/8 (29)	-
Table H	19 1/4 (489)	17 1/4 (438)	16	7/8 (22)	1 (25)	1 (25)	-	14 1/4 (362)	-	1/16 (2)	1 3/4 (44)	1 1/2 (38)	1 1/2 (38)	-

- (1) These flange thicknesses are also valid for ductile iron flanges type 21-2
- (2) For ductile iron pipes and fittings the outside diameter shall be: for PN10, D = 455mm; for PN16, D = 455 mm
- (3) Copper alloy flanges are always flat-faced

Nominal Size 350mm (14")

BS EN 1092	Dia. of flange	Bolt circle diameter	No. of bolts	Dia. of bolts	Dia. of holes Iron	Dia. of holes Steel	Dia. of raised face(3) Iron	Dia. of raised face(3) Steel	Height of raised face(3) Iron	Height of raised face(3) Steel	Thickness of flange			
											Grey Cast Iron	Copper Alloy	Cast and Forged Steel	Ductile Cast Iron
PN6	490	445	12	M20	23	22	413	415	4	2	26 (1)	-	22	-
PN10	505	460	16	M20	23	22	429	430	4	2	30 (1)	-	26	24.5
PN16	520	470	16	M24	28	26	429	438	4	2	36 (1)	-	30	26.5
PN25	555	490	16	M30	34	33	448	450	4	2	44 (1)	-	38	30
PN40	580	510	16	M33	37	36	465	465	4	2	-	-	46	44
PN64	600	525	16	M36	-	39	-	465	-	2	-	-	56	-
PN100	655	560	16	M45	-	48	-	465	-	2	-	-	74	-
ANSI														
Class 125/150	21 (533)	18 3/4 (476)	12	1 (25)	1 1/8 (29)	1 1/8 (29)	-	16 1/4 (413)	-	1/16 (2)	1 3/8 (35)	-	1 3/8 (35)	-
Class 300	23 (584)	20 1/4 (514)	20	1 1/8 (29)	-	1 1/4 (32)	-	16 1/4 (413)	-	1/16 (2)	-	-	2 1/8 (54)	-
Class 600	23 3/4 (603)	20 3/4 (527)	20	1 3/8 (35)	-	1 1/2 (38)	-	16 1/4 (413)	-	1/4 (6)	-	-	2 3/4 (70)	-
Class 900	25 1/4 (641)	22 (559)	20	1 1/2 (38)	-	1 5/8 (41)	-	16 1/4 (413)	-	1/4 (6)	-	-	3 (86)	-
Class 1500	29 1/2 (749)	25 (635)	16	2 1/4 (57)	-	2 3/8 (60)	-	16 1/4 (413)	-	1/4 (6)	-	-	5 1/4 (133)	-
BS 10														
Table A	20 3/4 (527)	18 1/2 (470)	8	7/8 (22)	1 (25)	1 (25)	-	-	-	-	1 (25)	1 (25)	-	-
Table D	20 3/4 (527)	18 1/2 (470)	12	7/8 (22)	1 (25)	1 (25)	-	-	-	-	1 1/8 (29)	1 (25)	1 (25)	-
Table E	20 3/4 (527)	18 1/2 (470)	12	7/8 (22)	1 (25)	1 (25)	-	-	-	-	1 1/4 (32)	1 (25)	1 (25)	-
Table F	21 3/4 (552)	19 1/2 (495)	16	1 (25)	1 1/8 (29)	1 1/8 (29)	-	-	-	-	1 3/8 (35)	1 1/4 (32)	1 1/4 (32)	-
Table H	21 3/4 (552)	19 1/2 (495)	16	1 (25)	1 1/8 (29)	1 1/8 (29)	-	16 1/2 (419)	-	1/16 (2)	1 7/8 (48)	1 5/8 (41)	1 5/8 (41)	-

- (1) These flange thicknesses are also valid for ductile iron flanges type 21-2
- (2) Copper alloy flanges are always flat-faced

Nominal Size 400mm (16")

BS EN 1092	Dia. of flange	Bolt circle diameter	No. of bolts	Dia. of bolts	Dia. of holes Iron	Dia. of holes Steel	Dia. of raised face(3) Iron	Dia. of raised face(3) Steel	Height of raised face(3) Iron	Height of raised face(3) Steel	Thickness of flange			
											Grey Cast Iron	Copper Alloy	Cast and Forged Steel	Ductile Cast Iron
PN6	540	495	16	M20	23	22	463	465	4	2	28 (1)	-	22	-
PN10	565	515	16	M24	28	26	480	482	4	2	32 (1)	-	26	24.5
PN16	580	525	16	M27	31	30	480	490	4	2	38 (1)	-	32	28
PN25	620	550	16	M33	37	36	503	505	4	2	48 (1)	-	40	32
PN40	660	585	16	M36	41	39	535	535	4	2	-	-	50	48
PN64	670	585	16	M39	-	42	-	535	-	2	-	-	60	-
PN100	715	620	16	M45	-	48	-	535	-	2	-	-	78	-
ANSI														
Class 125/150	23 ¹ / ₂ (597)	21 ¹ / ₄ (540)	16	1 (25)	1 ¹ / ₈ (29)	1 ¹ / ₈ (29)	-	18 ¹ / ₂ (470)	-	1 ¹ / ₁₆ (2)	1 ⁷ / ₁₆ (37)	-	1 ⁷ / ₁₆ (37)	-
Class 300	25 ¹ / ₂ (648)	22 ¹ / ₂ (572)	20	1 ¹ / ₄ (32)	-	1 ³ / ₈ (35)	-	18 ¹ / ₂ (470)	-	1 ¹ / ₁₆ (2)	-	-	2 ¹ / ₄ (57)	-
Class 600	27 (686)	23 ³ / ₄ (603)	20	1 ¹ / ₂ (38)	-	1 ⁵ / ₈ (41)	-	18 ¹ / ₂ (470)	-	1 ⁴ / ₁₆ (6)	-	-	3 (76)	-
Class 900	27 ³ / ₄ (705)	24 ¹ / ₄ (616)	20	1 ⁵ / ₈ (41)	-	1 ³ / ₄ (44)	-	18 ¹ / ₂ (470)	-	1 ⁴ / ₁₆ (6)	-	-	3 ¹ / ₂ (89)	-
Class 1500	32 ¹ / ₂ (826)	27 ³ / ₄ (705)	16	2 ¹ / ₂ (64)	-	2 ⁵ / ₈ (67)	-	18 ¹ / ₂ (470)	-	1 ⁴ / ₁₆ (6)	-	-	5 ³ / ₄ (146)	-
BS 10														
Table A	22 ³ / ₄ (578)	20 ¹ / ₂ (521)	12	7 ₈ (22)	1 (25)	1 (25)	-	-	-	-	1 ¹ / ₁₆ (27)	1 (25)	-	-
Table D	22 ³ / ₄ (578)	20 ¹ / ₂ (521)	12	7 ₈ (22)	1 (25)	1 (25)	-	-	-	-	1 ¹ / ₈ (29)	1 (25)	1 (25)	-
Table E	22 ³ / ₄ (578)	20 ¹ / ₂ (521)	12	7 ₈ (22)	1 (25)	1 (25)	-	-	-	-	1 ¹ / ₄ (32)	1 (25)	1 (25)	-
Table F	24 (610)	21 ³ / ₄ (552)	20	1 (25)	1 ¹ / ₈ (29)	1 ¹ / ₈ (29)	-	-	-	-	1 ³ / ₈ (35)	1 ¹ / ₄ (32)	1 ¹ / ₄ (32)	-
Table H	24 (610)	21 ³ / ₄ (552)	20	1 (25)	1 ¹ / ₈ (29)	1 ¹ / ₈ (29)	-	19 (483)	-	1 ¹ / ₁₆ (2)	2 (51)	1 ³ / ₄ (44)	1 ³ / ₄ (44)	-

(1) These flange thicknesses are also valid for ductile iron flanges type 21-2

(2) Copper alloy flanges are always flat-faced

Nominal Size 450mm (18")

BS EN 1092	Dia. of flange	Bolt circle diameter	No. of bolts	Dia. of bolts	Dia. of holes Iron	Dia. of holes Steel	Dia. of raised face(3) Iron	Dia. of raised face(3) Steel	Height of raised face(3) Iron	Height of raised face(3) Steel	Thickness of flange			
											Grey Cast Iron	Copper Alloy	Cast and Forged Steel	Ductile Cast Iron
PN6	595	550	16	M20	23	22	518	520	4	2	28 (1)	-	22	-
PN10	615	565	20	M24	28	26	530	532	4	2	32 (1)	-	28	25.5
PN16	640	585	20	M27	31	30	548	550	4	2	40 (1)	-	40	30
PN25	670	600	20	M33	37	36	548	555	4	2	50 (1)	-	46	34.5
PN40	685	610	20	M36	41	39	560	560	4	2	-	-	57	49
PN64	-	-	-	-	-	-	-	-	-	-	-	-	-	-
PN100	-	-	-	-	-	-	-	-	-	-	-	-	-	-
ANSI														
Class 125/150	25 (635)	22 ³ / ₄ (578)	16	1 ¹ / ₈ (29)	1 ¹ / ₄ (32)	1 ¹ / ₄ (32)	-	21 (533)	-	1 ¹ / ₁₆ (2)	1 ⁹ / ₁₆ (40)	-	1 ⁹ / ₁₆ (40)	-
Class 300	28 (711)	24 ³ / ₄ (629)	24	1 ¹ / ₄ (32)	-	1 ³ / ₈ (35)	-	21 (533)	-	1 ¹ / ₁₆ (2)	-	-	2 ³ / ₈ (60)	-
Class 600	29 ¹ / ₄ (743)	25 ³ / ₄ (654)	20	1 ⁵ / ₈ (41)	-	1 ³ / ₄ (44)	-	21 (533)	-	1 ⁴ / ₁₆ (6)	-	-	3 ¹ / ₄ (83)	-
Class 900	31 (787)	27 (686)	20	1 ⁷ / ₈ (48)	-	2 (51)	-	21 (533)	-	1 ⁴ / ₁₆ (6)	-	-	4 (102)	-
Class 1500	36 (914)	30 ¹ / ₂ (775)	16	2 ³ / ₄ (70)	-	2 ⁷ / ₈ (73)	-	21 (533)	-	1 ⁴ / ₁₆ (6)	-	-	6 ³ / ₈ (162)	-
BS 10														
Table A	25 ¹ / ₄ (641)	23 (584)	12	7 ₈ (22)	-	1 (25)	-	-	-	-	1 ¹ / ₁₆ (27)	1 ¹ / ₁₆ (27)	-	-
Table D	25 ¹ / ₄ (641)	23 (584)	12	7 ₈ (22)	-	1 (25)	-	-	-	-	1 ¹ / ₄ (32)	1 ¹ / ₈ (29)	1 ¹ / ₈ (29)	-
Table E	25 ¹ / ₄ (641)	23 (584)	16	7 ₈ (22)	-	1 (25)	-	-	-	-	1 ³ / ₈ (35)	1 ¹ / ₈ (29)	1 ¹ / ₈ (29)	-
Table F	26 ¹ / ₂ (673)	24 (610)	20	1 ¹ / ₈ (29)	-	1 ¹ / ₄ (32)	-	-	-	-	1 ¹ / ₂ (38)	1 ³ / ₈ (35)	1 ³ / ₈ (35)	-
Table H	26 ¹ / ₂ (673)	24 (610)	20	1 ¹ / ₈ (29)	-	1 ¹ / ₄ (32)	-	21 (533)	-	1 ¹ / ₁₆ (2)	2 ¹ / ₈ (54)	1 ⁷ / ₈ (48)	1 ⁷ / ₈ (48)	-

(1) These flange thicknesses are also valid for ductile iron flanges type 21-2

(2) Copper alloy flanges are always flat-faced

Nominal Size 500mm (20")

BS EN 1092	Dia. of flange	Bolt circle diameter	No. of bolts	Dia. of bolts	Dia. of holes Iron	Dia. of holes Steel	Dia. of raised face(3) Iron	Dia. of raised face(3) Steel	Height of raised face(3) Iron	Height of raised face(3) Steel	Thickness of flange			
											Grey Cast Iron	Copper Alloy	Cast and Forged Steel	Ductile Cast Iron
PN6	645	600	20	M20	23	22	568	570	4	2	30 (1)	-	24 (2)	-
PN10	670	620	20	M24	28	26	582	585	4	2	34 (1)	-	28 (2)	26.5
PN16	715	650	20	M30	34	33	609	610	4	2	42 (1)	-	44 (2)	31.5
PN25	730	660	20	M33	37	36	609	615	4	2	52 (1)	-	48 (2)	36.5
PN40	755	670	20	M39	44	42	615	615	4	2	-	-	57 (2)	52
PN64	800	705	20	M45	-	48	-	615	-	2	-	-	68 (2)	-
PN100	870	760	20	M52	-	56	-	615	-	2	-	-	94 (2)	-
ANSI														
Class 125/150	27 ¹ / ₂ (699)	25 (635)	20	1 ¹ / ₈ (29)	1 ¹ / ₄ (32)	1 ¹ / ₄ (32)	-	23 (584)	-	1 ¹ / ₁₆ (2)	1 ¹ / ₁₆ (43)	-	1 ¹ / ₁₆ (43)	-
Class 300	30 ¹ / ₂ (775)	27 (686)	24	1 ¹ / ₄ (32)	-	1 ³ / ₈ (35)	-	23 (584)	-	1 ¹ / ₁₆ (2)	-	-	2 ¹ / ₂ (64)	-
Class 600	32 (813)	28 ¹ / ₂ (724)	24	1 ⁵ / ₈ (41)	-	1 ³ / ₄ (44)	-	23 (584)	-	1 ¹ / ₄ (6)	-	-	3 ¹ / ₂ (89)	-
Class 900	33 ³ / ₄ (857)	29 ¹ / ₂ (749)	20	2 (51)	-	2 ¹ / ₈ (54)	-	23 (584)	-	1 ¹ / ₄ (6)	-	-	4 ¹ / ₄ (108)	-
Class 1500	38 ³ / ₄ (984)	32 ³ / ₄ (832)	16	3 (76)	-	3 ¹ / ₈ (79)	-	23 (584)	-	1 ¹ / ₄ (6)	-	-	7 (178)	-
BS 10														
Table A	27 ³ / ₄ (705)	25 ¹ / ₄ (641)	12	7 ⁷ / ₈ (22)	1 (25)	1 (25)	-	-	-	-	1 ¹ / ₈ (29)	1 ¹ / ₈ (29)	-	-
Table D	27 ³ / ₄ (705)	25 ¹ / ₄ (641)	16	7 ⁷ / ₈ (22)	1 (25)	1 (25)	-	-	-	-	1 ¹ / ₄ (32)	1 ¹ / ₄ (32)	-	-
Table E	27 ³ / ₄ (705)	25 ¹ / ₄ (641)	16	7 ⁷ / ₈ (22)	1 (25)	1 (25)	-	-	-	-	1 ¹ / ₂ (38)	1 ¹ / ₄ (32)	1 ¹ / ₄ (32)	-
Table F	29 (737)	26 ¹ / ₂ (673)	24	1 ¹ / ₈ (29)	1 ¹ / ₄ (32)	1 ¹ / ₄ (32)	-	-	-	-	1 ⁵ / ₈ (41)	1 ¹ / ₂ (38)	1 ¹ / ₂ (38)	-
Table H	29 (737)	26 ¹ / ₂ (673)	24	1 ¹ / ₈ (29)	1 ¹ / ₄ (32)	1 ¹ / ₄ (32)	-	23 ¹ / ₂ (597)	-	1 ¹ / ₁₆ (2)	2 ¹ / ₄ (57)	2 (51)	2 (51)	-

- (1) These flange thicknesses are also valid for ductile iron flanges type 21-2
- (2) These flange thicknesses are changed substantially as a result of the flange calculation method used in BS EN 1092-1
- (3) Copper alloy flanges are always flat-faced

Nominal Size 600mm (24")

BS EN 1092	Dia. of flange	Bolt circle diameter	No. of bolts	Dia. of bolts	Dia. of holes Iron	Dia. of holes Steel	Dia. of raised face(3) Iron	Dia. of raised face(3) Steel	Height of raised face(3) Iron	Height of raised face(3) Steel	Thickness of flange			
											Grey Cast Iron	Copper Alloy	Cast and Forged Steel	Ductile Cast Iron
PN6	755	705	20	M24	28	26	667	670	5	2	30 (1)	-	30	-
PN10	780	725	20	M27	31	30	682	685	5	2	36 (1)	-	34	30
PN16	840	770	20	M33	37	36	720	725	5	2	48 (1)	-	54	36
PN25	845	770	20	M36	41	39	720	720	5	2	-	-	58	42
PN40	890	795	20	M45	50	48	735	735	5	2	-	-	72	58
PN64	930	820	20	M52	-	56	-	735	-	2	-	-	76	-
ANSI														
Class 125/150	32 (813)	29 ¹ / ₂ (749)	20	1 ¹ / ₄ (32)	1 ³ / ₈ (35)	1 ³ / ₈ (35)	-	27 ¹ / ₄ (692)	-	1 ¹ / ₁₆ (2)	1 ⁷ / ₈ (48)	-	1 ⁷ / ₈ (48)	-
Class 300	36 (914)	32 (813)	24	1 ¹ / ₂ (38)	-	1 ⁵ / ₈ (41)	-	27 ¹ / ₄ (692)	-	1 ¹ / ₁₆ (2)	-	-	2 ³ / ₄ (70)	-
Class 600	37 (940)	33 (838)	24	1 ⁷ / ₈ (48)	-	2 (51)	-	27 ¹ / ₄ (692)	-	1 ¹ / ₄ (6)	-	-	4 (102)	-
Class 900	41 (1041)	35 ¹ / ₂ (902)	20	2 ¹ / ₂ (64)	-	2 ⁵ / ₈ (67)	-	27 ¹ / ₄ (692)	-	1 ¹ / ₄ (6)	-	-	5 ¹ / ₂ (140)	-
Class 1500	46 (1168)	39 (991)	16	3 ¹ / ₂ (89)	-	3 ⁵ / ₈ (92)	-	27 ¹ / ₄ (692)	-	1 ¹ / ₄ (6)	-	-	8 (203)	-
BS 10														
Table A	32 ¹ / ₂ (826)	29 ³ / ₄ (756)	12	1 (25)	1 ¹ / ₈ (29)	1 ¹ / ₈ (29)	-	-	-	-	1 ³ / ₁₆ (30)	1 ³ / ₁₆ (30)	-	-
Table D	32 ¹ / ₂ (826)	29 ³ / ₄ (756)	16	1 (25)	1 ¹ / ₈ (29)	1 ¹ / ₈ (29)	-	-	-	-	1 ³ / ₈ (35)	1 ³ / ₈ (35)	1 ³ / ₈ (35)	-
Table E	32 ¹ / ₂ (826)	29 ³ / ₄ (756)	16	1 ¹ / ₈ (29)	1 ¹ / ₄ (32)	1 ¹ / ₄ (32)	-	-	-	-	1 ⁵ / ₈ (41)	1 ¹ / ₂ (38)	1 ¹ / ₂ (38)	-
Table F	33 ¹ / ₂ (851)	30 ³ / ₄ (781)	24	1 ¹ / ₄ (32)	1 ¹ / ₄ (32)	1 ³ / ₈ (35)	-	-	-	-	1 ³ / ₄ (44)	1 ⁵ / ₈ (41)	1 ⁵ / ₈ (41)	-
Table H	33 ¹ / ₂ (851)	30 ³ / ₄ (781)	24	1 ¹ / ₄ (32)	1 ³ / ₈ (35)	1 ³ / ₈ (35)	-	27 ¹ / ₂ (699)	-	1 ¹ / ₁₆ (2)	2 ¹ / ₂ (64)	2 ¹ / ₄ (57)	2 ¹ / ₄ (57)	-

- (1) These flange thicknesses are also valid for ductile iron flanges type 21-2
- (2) These flange thicknesses are changed substantially as a result of the flange calculation method used in BS EN 1092-1
- (3) Copper alloy flanges are always flat-faced

Typical Kv values for various valves to enable Pressure Drop calculations to be made.
For other pipe specifications, valve sizes and valve types, please refer to Crane Fluid Systems.

GATE VALVES (SCHEDULE 40 PIPE)

SIZE (mm)	15	20	25	32	40	50	65	80	100	125	150	200	250	300
Kv	21.32	38.88	65.69	116.23	161.93	280.6	411.33	635.13	1125.41	1823.03	2718.96	4873.47	7681.73	11315.64

GLOBE VALVES (SCHEDULE 40 PIPE)

SIZE (mm)	15	20	25	32	40	50	65	80	100	125	150	200	250	300
Kv	3.27	5.96	10.08	17.83	24.84	43.04	63.1	97.42	172.63	279.64	417.07	747.56	1178.32	1735.74

BUTTERFLY VALVES

SIZE (mm)	15	20	25	32	40	50	65	80	100	125	150	200	250	300
Kv	-	-	-	-	-	133	240	410	655	900	1800	3550	7350	9100

BALL VALVES

SIZE (mm)	8	10	15	20	25	32	40	50	65	80
Kv	9	11	20	47	77	1412	198	338	593	82

CHECK VALVES (SCHEDULE 40 PIPE)

SIZE (mm)	15	20	25	32	40	50	65	80	100	125	150	200	250	300
Kv	8.53	15.55	26.27	46.49	64.77	112.24	164.53	254.05	450.16	729.21	1087.59	1949.39	3072.69	4526.25

STRAINERS (FLANGED) (BS 1387 Medium Grade Steel Pipe)

SIZE (mm)	15	20	25	32	40	50	65	80	100	125	150	200	250	300
Kv	-	-	-	-	33	57	91	131	232	372	544	952	1470	2151

STRAINERS (THREADED) (BS 1387 Medium Grade Steel Pipe)

SIZE (mm)	15	20	25	32	40	50
Kv	4.8	8.8	16.1	25.5	36	68

COMMISSIONING VALVES (Fixed Orifice Double Regulating Valve - Crane DM941)

SIZE (mm)	65	80	100	125	150	200	250	300
Kv	72	100	124	229	324	525	1058	1329

COMMISSIONING VALVES (Fixed Orifice Double Regulating Valve - Crane D931)

SIZE (mm)	15	20	25	32	40	50
Kv	1.87	3.14	5.59	10.8	18.1	29.1

Rigid quality control and inspection at all stages of manufacture ensure that Crane FS products are suitable for their intended application and will give reliable service. Every valve and pipe fitting is individually tested in accordance with the relevant product standard.

Crane Fluid Systems is an approved manufacturer under various quality schemes, including the British Standard Institution (BSI) Kitemark, and is ISO9001 accredited. In addition, the company has been approved and/or listed by various user organisations including the United Kingdom Water Fittings by laws scheme and other third party organisations.



NSF/WRc Evaluation and Testing Centre

The NSF Evaluation and Testing Centre is responsible for the Water Regulations Advisory Scheme, with testing and approval of water fittings meeting the requirements of the United Kingdom Water Regulations/Bylaws (Scotland).

Valves for use in public water supply systems and domestic situations must not contravene the United Kingdom Water Regulations. Valves which are designated WRAS Approved Product and listed in the Water Fittings and Materials Directory will not contravene those bylaws.

Many Crane Fluid Systems valves have been tested and certified as being WRAS Approved Products and are listed in the Water Fittings and Materials Directory.

Pressure Equipment Directive



All Crane Fluid Systems products have been assessed in accordance with the Pressure Equipment Directive (PED) 2014/68/EU.

Currently, each product has been classified into a conformity assessment category based on the intended fluid contents – gas or liquid, the classification of the intended fluid contents

– Group 1 or Group 2, and the maximum allowable pressure and the nominal size (DN).

Crane FS products fall into either the ‘Sound Engineering Practice’ (SEP), Category 1, Category 2, Category 3, or category 4. According to the directive, products classified as ‘SEP’ shall not be CE marked. Category 1 products will bear the CE mark and those products classified as Categories 2,3 and 4 will bear the CE mark plus the number 0041.

The number 004 is that of Bureau Veritas who Crane FS have chosen as their ‘Notified Body’ to monitor their quality assurance system as required by the directive.



Firm of Assessed Capability

BS EN/ISO 9001 is the reference Standard for Quality Systems.



The Kitemark

The Kitemark is a registered trademark owned by British Standards Institution and may only be used by manufacturers who are approved

licensees and whose products fully comply with the individual product standards.

Annual product audits and regular surveillance visits by BSI ensure continuing compliance with specification requirements and confirm acceptable Quality Systems to BS EN ISO 9001:2015.

Classification of Gases and Liquids

Gases

GROUP ONE
<ul style="list-style-type: none"> • Explosive • Extremely Flammable • Highly Flammable • Very Toxic • Toxic • Oxidising
GROUP TWO
<ul style="list-style-type: none"> • Others

Liquids

GROUP ONE
<ul style="list-style-type: none"> • Explosive • Extremely Flammable • Highly Flammable • Very Toxic • Toxic • Oxidising
GROUP TWO
<ul style="list-style-type: none"> • Others (including steam)

Valid as of 130218

Every effort has been made to ensure that the information contained in this publication is accurate at the time of publishing. Crane Ltd assumes no responsibility or liability for typographical errors or omissions or for any misinterpretation of the information within the publication and reserves the right to change without notice.

FINANCIAL

PROJECT

5 Broadgate



Crane Fluid Systems has supplied thousands of valves for the core and shell build of 5 Broadgate, located in London's Square Mile.

5 Broadgate is the new home of UBS a global bank which provides comprehensive financial services around the world and make decisions that can have multi million pound consequences. In fact, 5 Broadgate has become the largest trading floor in Europe, so it is essential that the heating and ventilation systems will never fail.

This world class office building provides over 66,890 sq m of new space, delivering state-of-the-art trading facilities to clients and staff. The development also includes public realm and landscaping enhancements from Sun Street Passage to Primrose Street, and allows for the introduction of retail space in the new Sun Street Square. British Land and GIC see the development of Broadgate as an important and positive milestone for Broadgate and for the City of London as a whole.

LOCATION:

London

DISTRIBUTOR:

BSS

CONTRACTOR:

S F Group

CONSULTANT:

Watkins Payne

CLIENT:

Bluebutton Property Management Ltd

ARCHITECT:

Make Architects

SPECIFICATION:

Heating and domestic general valves, balancing & PICVs



Snapshot	Project	Sector	Location	Page
	DisneyLand	Leisure	Hong Kong	6
	Arsenal Emirates Stadium	Sports & Leisure	London, UK	10-11
	Mall of Egypt	Commercial & Retail	Cairo, Egypt	27
	Kempinski Hotel Marsa Malaz, Doha	Hotels & Leisure	Doha, Qatar	45
	Piccadilly Gate	Public Sector	Manchester, UK	46
	Lyric Theatre	Arts	London, UK	47
	M&S Carmine Building	Commercial & Retail	London, UK	64-65
	Qatar National Rail Scheme, Qatar	Infrastructure	Qatar	100
	King Cross Energy Centre	Infrastructure	London, UK	101
	Phase III, The Avenues	Retail	Kuwait	119
	Steigenberger, Hotel Tahrir Square, Cairo	Hotels & Leisure	Cairo, Egypt	132
	Tate Modern	Leisure	London, UK	133
	HSBC Data Centre	Financial Sector	Hong Kong	141
	Domino's Pizza HQ	Food Industry	Milton Keynes, UK	142-143
	5 Broadgate	Financial	London, UK	156

CRANE FLUID SYSTEMS

Today as part of the Crane Building Services & Utilities, Crane Fluid Systems is joined by an array of complimentary building services brands, including:



NABIC

One of the UK's leading suppliers of gunmetal safety valves, NABIC has long been recognised as the industry standard for commercial and industrial hot water applications. In fact, NABIC valves are ideal for hot water supply, heating, pump relief, bypass relief, outside installation and for use with different gases and liquids.



Wade

An extensive range of low and medium pressure, brass compression fittings, needle valves and accessories. The range also covers SISTEM-P and compact push-in fittings, nickel-plated BSP fittings, silencers, safety relief valves for compressed air, nylon and copper tubing.



VIKING JOHNSON

Viking Johnson is a world leader in the manufacture and supply of couplings, flange adaptors, pipe repair and jointing solutions for the international water, wastewater, gas and industrial markets. Products are suitable for dedicated and wide tolerance application ranging from 15mm to 5000mm in diameter, and can be used to connect or repair many types of pipe material.



WASK

Market leader in the supply of specialist mains and service fittings, along with pipeline equipment of the highest quality, WASK is renowned in the global gas distribution market. WASK Teeset and bagging-off equipment has become a standard in the UK gas industry and in many markets overseas.

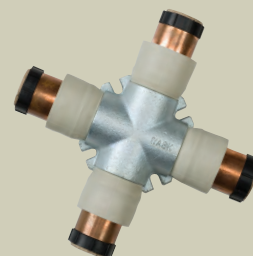

Latest additions to the range include a unique riser and lateral modular system which allows PE pipework to supply gas into single or multiple occupancy dwellings. WASK has a reputation as a leader in producing innovative and safe gas control valves.

SPERRYN GAS CONTROLS

Sperryn is a leading supplier of meter installation kits and emergency control valves for domestic, commercial and industrial applications. Using the latest design facilities and technologies, Sperryn regulators offer increased capacity, accuracy and lower pressure drops.

Where applicable, fittings and control valves comply with the requirements of the relevant British Gas Engineering Standards.



POSIFLEX

PosiFlex expansion joints provide relief for piping system stress caused by thermal and mechanical vibration and/or movement, and can also be utilised to overcome problems of noise. These flexible connectors are fabricated from a wide range of rubber compounds, open or filled, single or multiple arch and are designed to accommodate the needs of individual pipe systems conveying materials as diverse as fluids, foodstuffs, chemicals or crude oil.

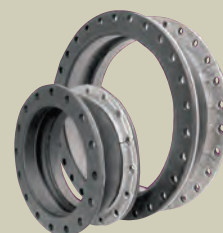

Valid as of 120220

Distributor details

To visit our Video Library go to:



www.youtube.com/user/CraneBSU



FM00311

EMS 553775

CRANE FLUID SYSTEMS

CRANE HOUSE, EPSILON TERRACE
WEST ROAD, IPSWICH
SUFFOLK IP3 9FJ

TELEPHONE: +44 (0)1473 277300

FAX: +44 (0)1473 277301

EMAIL: UK Sales enquires: enquiries@cranefs.com
Technical enquires: tech-enquiries@crane-ltd.co.uk

MIDDLE EAST, ASIA & AFRICA SALES OFFICE
BUILDING 4, OFFICE 901, THE GALLERIES,
DOWNTOWN JEBEL ALI, DUBAI PO BOX 17415

TELEPHONE: +9714 816 5800

FAX: +44 (0)1473 277301

EMAIL: mena-enquiries@cranefs.com

www.cranefs.com

- Designed and manufactured under quality management systems in accordance with BS EN ISO 9001.
- We hope our communications have an impact on you - but not the environment - we have taken steps to select a FSC certified printer to ensure this brochure is printed on Forestry Stewardship Council® certified material and the paper is made by an elemental chlorine free.



PRINTED ON PAPER FROM
SUSTAINABLE SOURCES

Printed in the UK



Visit www.flowoffluids.com to order your copy of the New Technical Paper 410

Every effort has been made to ensure that the information contained in this publication is accurate at the time of publishing. Crane Ltd assumes no responsibility or liability for typographical errors or omissions or for any misinterpretation of the information within the publication and reserves the right to change without notice.

01.03.2020